

GAS-VOLUME CONVERSION DEVICE

miniELCOR

Device Description
Operation Manual
Technical Description
Mounting instructions
Device settings



Single-channel conversion device of gas volume at measurement conditions to volume at base conditions. Approved for installation in potentially explosive atmospheres.

CE **M 09** 1383
1026

PRELIMINARY

January 2010
Rev. 6g



Safety Measures

This measurement device can be operated only by an operator trained in compliance with the technical terms, safety regulations, and standards. It is necessary to consider any other legal and safety regulations stipulated for special applications. Similar measures also apply for special applications. Similar measures also apply for using the accessories. The operator training must be in compliance with Decree no. 50.1978 Coll.

The information in this manual does not have the burden of a legal obligation from the manufacturer's side. The manufacturer reserves the right to implement changes. Any changes in the manual or in the product itself can be performed at any time without any previous alert, with the goal of improving the device or fixing any typographical or technical mistakes.

TABLE OF CONTENTS

1	Introduction	1
1.1	Basic device description	1
1.2	Function principle.....	2
1.3	Device dimensions.....	7
2	Device technical description	7
2.1	Device architecture	7
2.2	Device power supply	8
2.3	Security marks.....	11
2.4	Product label	13
3	Safety instructions.....	14
3.1	General	14
3.2	Use in potentially explosive atmospheres	14
3.3	Risks of usage	14
3.4	Special conditions of use	15
3.5	Using device variants for different groups of gas	15
4	Metrology characteristics	16
4.1	Measuring temperature	16
4.2	Measuring pressure.....	16
4.3	Compressibility calculation.....	17
4.4	Volume measuring and calculation.....	18
5	Connecting inputs and outputs.....	21
5.1	Inputs.....	21
5.2	Outputs	25
5.3	Adding of another pressure or temperature transducer	26
6	Communication with device	29
6.1	RS-232 and RS-485 interfaces	29
6.2	Optical interface IEC-1107	31
7	Description of function.....	33
7.1	Measurand marking	33
7.2	Instantaneous values.....	33
7.3	Archives	34
7.4	Device parameterization	37
7.5	Other device functions	38

7.6	Securing the device against a change of metrology parameters	38
8	Putting in operation	44
9	Device operation	45
9.1	Keypad	45
9.2	Menu system.....	46
9.3	Main menu	49
9.4	Instantaneous values menu.....	50
9.5	Stored values menu.....	50
9.6	Device parameters menu.....	51
9.7	Parameter settings menu	52
9.8	System data menu.....	53
9.9	Diagnostics menu	54
10	Mounting instructions	57
10.1	Mechanical mounting of the device.....	57
10.2	Cable connection, grounding	61
11	Accessories.....	63
11.1	Assembly accessories	63
11.2	Intrinsically safe supply sources for external power supply	63
11.3	Separation and communication modules	63
11.4	GPRS communicators	63
11.5	Other accessories	63
12	Technical parameters	64
13	Inexplosiveness parameters	70
14	Device setting.....	72
14.1	Standard device control after installation.....	72
14.2	Device connection with PC	73
14.3	Setting of communication between device and PC	73
14.4	Password in the device	84
15	Configuration examples.....	86
15.1	Device parameters displaying.....	86
15.2	Gas meter constant setting.....	86
15.3	Pulse outputs setting.....	89
15.4	Analogue output setting.....	94
15.5	Setpoint setting – limit values of measured quantity.....	97

15.6	Setting of external power supply failure.....	100
15.7	Setting of communication through MODBUS protocol	101
16	Pressure and temperature sensor/transducer replacement	105
16.1	Pressure and temperature sensor/transducer replacement procedure in miniELCOR device.....	105
16.2	Software settings of device for proper communication with new temperature sensor.....	105
16.3	Software settings of device for proper communication with new pressure transducer	108
17	Software settings of the device for proper communication with external digital temperature (EDT-34) or pressure transducer (EDT-23)	109
17.1	Adding of digital transducer into device's parameters.....	109
17.2	Adding of quantity measured by digital transducer into device's archives.....	110
18	Final verification of the device after replacement of sensor/transducer or adding of digital transducer	111
19	What to do if something does not work	116
20	Literature	119
21	Relevant Literature.....	119
22	Software.....	120
23	Used trade marks	120
24	List of figures	121
25	List of Tables	123

Used symbols and definitions

<i>Symbol</i>		<i>Meaning</i>	<i>Unit</i>
AGA8-G1	...	Calculation method of gas compressibility factor	
AGA8-G2	...	Calculation method of gas compressibility factor	
AGA8-92DC	...	Calculation method of gas compressibility factor	
AGA NX-19 mod	...	Calculation method of gas compressibility factor	
ASC	...	Accredited Service Center	
BTS	...	Base Transceiver Station	
CL 1	...	Module for realization of product output 4-20mA	
CRC	...	Checksum – used for data protection	
CTR	...	Communication protocol	
DATCOM-Kx	...	Some of the products of series DATCOM-K (DATCOM-K1, DATCOM-K2, DATCOM-K3, DATCOM-K3/A, DATCOM-K4, DATCOM-K4/A)	
DLMS	...	Communication protocol	
DC	...	Direct Current voltage	
dE	...	addition (difference) of energy	MJ
dV	...	addition (difference) of primary volume V_m or V_c	m^3
dV _b	...	addition (difference) of base volume	m^3
dV _c	...	addition (difference) of corrected primary volume	m^3
dV _m	...	addition (difference) of primary volume	m^3
E	...	Energy	MJ
E _s	...	Estimated value of energy	MJ
EDTxx	...	Digital pressure or temperature transducer EDT 23 or EDT 34	
EMC	...	Electromagnetic compatibility and resistance	
EMI	...	Electromagnetic radiation	
firmware, FW	...	Software equipment loaded in the device	
GOST NX-19	...	Method of gas compressibility calculation (related with AGA NX-19 mod) according to VNIMS directive (valid at temperature range -23°C to +60°C)	GOST NX-19
H _s	...	Combustion heat	MJ/m ³
IS	...	intrinsic safety, intrinsically safe	
JBZ-0x	...	Some of the JBZ-01, JBZ-02, JBZ-02/A products	
Modbus	...	Communication protocol designed by Modicon [15]	
M900	...	Specific communication protocol	
SGERG-88	...	Calculation method of gas compressibility factor, more details in Chyba! Nenalezen zdroj odkazů.	
SNAM	...	Communication protocol	
SW	...	Software for PC	
C	...	Conversion factor	-
K	...	Ratio of compressibility factors (Z/Z_b)	-
k _p	...	Gas meter constant (number of impulses per 1 m ³)	imp/m ³
N	...	Number of input impulses from gas meter	imp
p	...	Absolute pressure at measurement conditions	kPa
p _b	...	Absolute pressure at base conditions	kPa

Q_m	...	Flowrate at measurement conditions (further primary flowrate)	m^3/h
Q_b	...	Flowrate at base conditions	m^3/h
T	...	Absolute temperature at measurement conditions ($T = t + 273.15$)	K
t	...	Gas temperature	$^{\circ}C$
T_b	...	Absolute temperature at base conditions	K
V	...	Volume V_m or V_c	
V_m	...	Volume at measurement conditions (further primary volume)	m^3
V_c	...	Corrected volume at measurement conditions (volume corrected based on correction curve of gasmeter)	m^3
V_b	...	Volume at base conditions (hereinafter also the standardized volume)	m^3
V_{bs}	...	Error volume at base conditions (hereinafter also the error standardized volume)	m^3
V_s	...	Error volume at measurement conditions (hereinafter also the error operational volume)	m^3
V_d	...	Difference of primary volume	m^3
V_{bd}	...	Difference of base volume	m^3
V_f	...	Tariff pulse counter of primary volume	
V_{bf}	...	Tariff pulse counter of base volume	
Z	...	Compression gas factor at measurement conditions	
Z_b	...	Compression gas factor at base conditions	

Notice :

This handbook issue describes device functions with firmware FW 4.xx which is compatible with previous firmware version 2.xx. All different features will be mentioned respectively.

Chapters describing new device features of FW ver. 4.xx are marked with (*).

1 Introduction

1.1 Basic device description

The Gas-volume conversion device miniELCOR (hereinafter only “the device”) is a measuring instrument designed for the conversion of the gas volume measure at measurement conditions to volume at base conditions.

The information on the gas volume passing through is measured using the impulse outputs of the gas meter. The gas temperature and pressure are measured by integrated converters. The device calculates the ratio of compressibility factors of gas using standard methods or a constant value is used.

The device has been constructed and approved pursuant to the EN 12405-1 standard as a conversion device type 1 (compact system) and can be supplied as a T, PT, or PTZ conversion device.

From safety point of view device is constructed according to EN 60079-11 like intrinsic safe.

It is manufactured and supplied in compliance with the following European Parliament directives:

- 1994/9/EC Equipment and protective systems for use in potentially explosive atmospheres
- 2004/108/EC Electromagnetic compatibility
- 2004/22/EC Directive on measuring instruments

Device is put onto market and into usage according to above mentioned standards and is marked with CE mark.

The device is built in a casing with sturdy plastic with IP66 protection. It is equipped with a graphic display and a 6-button keypad. Furthermore, it has impulse inputs for the connection of a gas meter with LF or HF impulse output and binary inputs. Device with FW version 4.xx and higher is suitable for connection via encoder NAMUR or SCR. If applied encoder SCR the only miniELCOR SCR1 variant is allowed. The binary inputs can work as check inputs to check the connection with a gas meter or can have a different function, e.g. monitoring the conditions of safety snap locks, doors, etc. The device has 4 available outputs. These can be configured as impulse or binary outputs, or as data outputs for the CL-1 module. When using this module, an analog current output can be realized.

The device is powered by a lithium battery. The life cycle of the battery is 6 years in the defined work mode. In the case of a battery power supply, one can also use the impulse outputs. An external power supply source can be used in applications with higher demands.

The device has a data archive of the measured values with an adjustable structure and storing period. The binary archive stores changes on the binary inputs and the occurrence of the monitored events (limits, etc.) Error conditions are stored in an status archive. It is possible to program the storing of important quantities and calculations and storage of some statistical values in the daily and monthly archive. The archive has settings for service and metrology; in case of changes of settings, the acts influencing the device parameters are recorded. The other logs are available as well , see more in 7.3.

For communication with its superior system, the device has a serial interface RS-232 and RS-485. Various communication protocols installed in the device allow easier connection to the SCADA systems. The device cooperates with common phone, radio, GSM, and GPRS modems, and in case of an alarm condition, it can initiate the connection.

The device can be enhanced by one non-metrology converter for measuring pressure or temperature. This enhancement can be performed without breaking the official mark on an already installed device.

1) Basic configuration of the device offers following inputs and outputs:

- analog input (pressure P - metrologic channel)
- analog input (temperature T - metrologic channel)
- 4x digital input DI1 to DI4 (binary, pulse); input DI1 can be used for connecting encoder NAMUR
- 4x digital output DO1 to DO4 (binary, pulse, analog)
- communication channel RS485/RS232 for communication with supordinate system
- input of external power supply
- option: connection one digital pressure or temperature transmitter EDTxx (as non-metrologic) to internal bus by help expansion board KP 065 08. This enhancement can be accomplished by end user on already installed device without breaching of metrological seal.

2) Device variant with SCR encoder ensures following inputs and outputs:

- The same like at basic device variant (see ad 1) however without possibility of connection of digital transducer EDTxx
- 1x input for SCR encoder connection by means of extension board KP 065 09

The device can be configured using the supplied SW [22] for PCs. This SW also allows the readout, display and archive of both the immediate measured values as well as the contents of the internal device archives.

1.2 Function principle

1.2.1 Conversion using equation of state

The device obtains data on the gas flowing through via impulses (N) from an If or hf sensor located in the gas meter. The volume at the measuring conditions (V) is calculated from the number of impulses (N) and gas meter constant (k_p).

The device obtains other data on the gas flowing through from the temperature and pressure converters – gas temperature (t) and absolute pressure at measuring conditions (p). This data is used to calculate the conversion factor (C) which is influenced also by these other factors: Absolute temperature at base conditions (T_b), absolute pressure at base conditions (p_b) and compressible factor of the gas at base conditions (Z_b).

Volume at measuring conditions (operational volume):

$$V = \frac{N}{k_p}$$

Ratio of compressibility factor:

$$K = \frac{Z}{Z_b}$$

Conversion factor:

$$C = \frac{p}{p_b} * \frac{T_b}{(t + 273.15)} * \frac{1}{K}$$

Volume at base conditions (standardized volume):

$$V_b = V * C$$

Gas compressibility factor expresses the deviation of properties of natural gas from the properties of an ideal gas. By setting the parameters, it is possible to choose a specific method for calculation of the compressibility factor pursuant to the standard (AGA NX-19 mod, AGA8-G1, AGA8-G2, SGERG-88 or AGA8-92DC). A constant compressibility value can be used for other gases besides natural gas. If the pressure or temperature value gets out of the limits of validity of the chosen standard for calculation of compressibility, the device calculates using a default compressibility value.

The device calculates the gas flow from the impulse frequency on the input in real time using mathematical filtration from the input signal.

Operational flow:

$$Q = \Delta V / \Delta t \text{ [m}^3\text{/h]}$$

Where: ΔV *increment of operational volume*

Δt *time between the impulses with an accuracy of one hundredth of a second*

The value of the immediate flow displayed on the converter display is updated every 10 seconds.

Standardized flow:

$$Q_b = C * \Delta V / \Delta t \text{ [m}^3\text{/h]}$$

1.2.2 Error values of volumes at measuring conditions and volumes at base conditions

For calculation during error conditions (i.e. in case of a converter error, deviation of the quantity value from the working range, or device error), the device has counters of the error volume at measuring conditions (V_s) and error volume at base conditions (V_{bs}). These counters are interconnected with the pertinent counters of volume at normal conditions.

A detailed description of device behavior during normal and error conditions is in Article 4.4.

1.2.3 Volume correction at measurement conditions

Device enables to compensate gasmeter error according to predefined correction curve from gasmeter test certificate. This function and parameters V_c can be activated only by manufacturer or by Accreditive service to ensure that used gasmeter correction curve in dependance on flowrate Q_m is valid within working conditions.

Error of measurement is corrected by usage of function $f(Q_m)$. For corrected volume is:

$$V_c = V_m \times f(Q_m)$$

where

V_c	...	Corrected volume at measurement conditions
V_m	...	Primary volume
Q_m	...	Primary flowrate

Linear interpolation method is used for getting values between calibration points. File with correction values is to be inserted into device with help of service programme 22. Information about insertion of correction curve into device is logged in setup archive.

The principle of volume calculation are seen on Fig. 1

Condition for usage of volume correction.

1. Correction is used only in case that gasmeter transmits at least 10 pulses per second resulting in usage only HF sensors.
2. Under Q_{min} correction is not applied and over Q_{max} value of correction coefficient given for Q_{max} will be used.

Conversion of volume on energy (*)

Device enables to calculate consumed quantity of gas directly in energy form.

This conversion uses value of combustion heat H_s . Calculation is made with adding of differences dV_b (and dV_{bs}) multiplied by actual value of combustion heat H_s .

$$dE = H_s \times dV_b, \quad dE_s = H_s \times dV_{bs}$$

Two other counters (energy counter E and estimated energy counter E_s) are dedicated for measurement in configurable energy units: MJ, kWh, Btu.

Note :

No conversion of absolute counter value (E or E_s) is accomplished after change of units. Following increases are added already respecting new units.

Principle diagram of energy calculation is drawn at Fig. 1

Combustion heat H_s

To get correct conversion it is necessary to enter correct value of combustion heat and relative conditions. Then device will make new conversion of relative temperature for defined relative conditions and final value will be used for energy calculation. In case of AGA8-92DC method combustion heat is not entered but calculated directly from gas composition according to EN ISO 6976. For the other methods value H_s (MJ/m³) must be entered manually and always under those relative conditions:

combustion temperature/ temperature of gas = 25°C / 0 °C

1. Basic measurement of primary volume

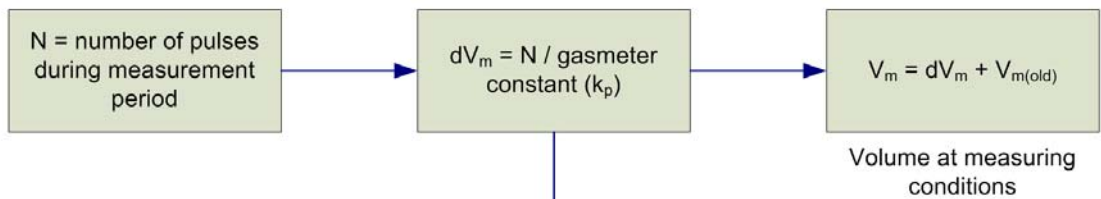

2. Application of gasmeter correction

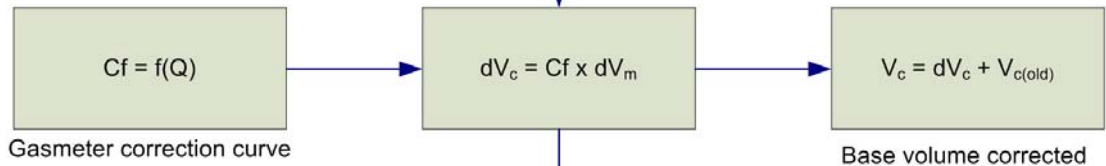

$dV = dV_c$
or
 $dV = dV_m$

3. Volume correction under standard condition

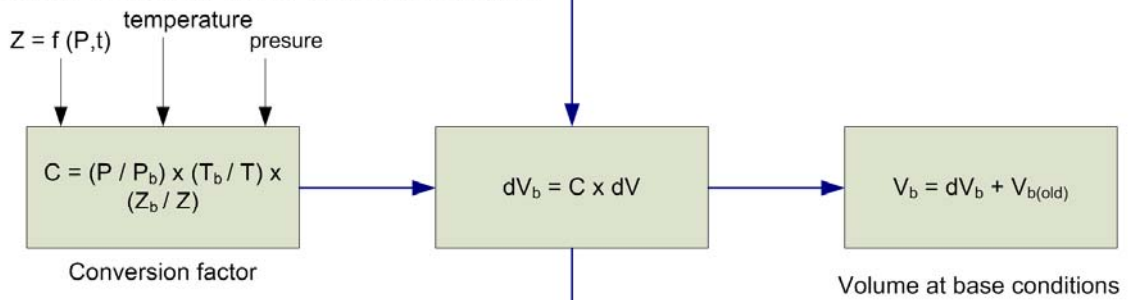

4. Conversion of standard volume onto energy

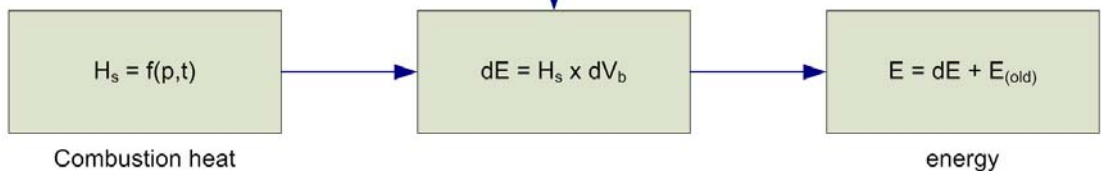

LEGEND:			
C	conversion factor	T	absolute temperature at measurement conditions
Cf	gasmeter volume correction	Tb	absolute temperature at base conditions
dE	energy addition	V	volume Vm or Vc
dV	adition dVm or dVc	Vb	volume at base condition (standardized volume)
dVb	adition base volume	Vb(old)	standard volume at the end of previous measurement period
dVc	adition corrected primary volume	Vc	corrected volume at measurement conditions
dVm	adition primary volume	Vc(old)	corrected volume at the end of previous measurement period
E	energy	Vm	volume at measurement conditions (primary volume)
E(old)	energy at the end of previous measurement period	Vm(old)	primary volume at the end of previous measurement period
Hs	combustion heat	Z	Gas compressibility factor at measurement conditions
P	absolute pressure of gas	Zb	Gas compressibility factor at base conditions
Pb	absolute pressure at base conditions		

Fig. 1 Volume and energy calculations - Scheme

1.3 Device dimensions

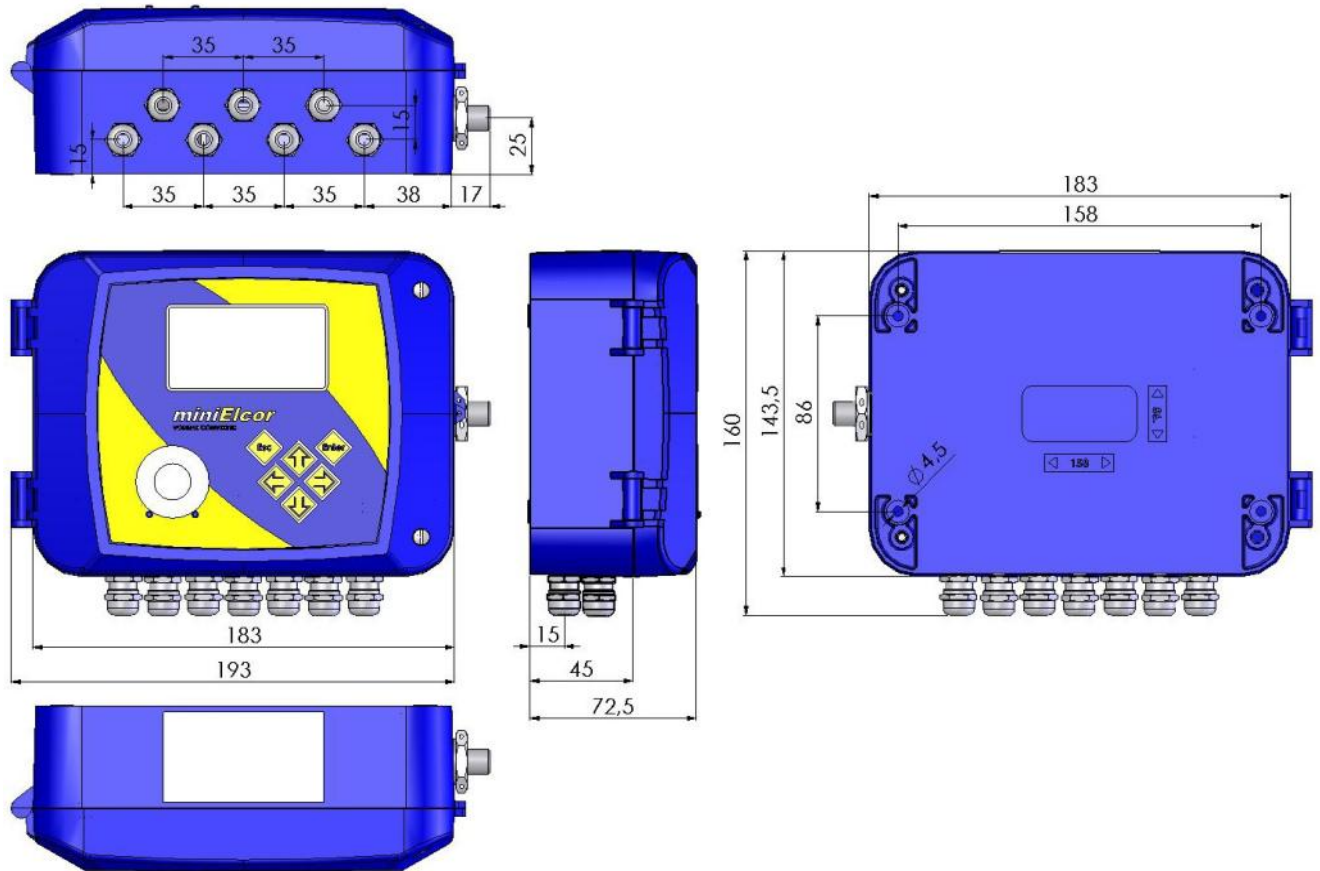

Fig. 2 Device dimensions

2 Device technical description

2.1 Device architecture

The device's electronics are laid out on three basic boards.

The bottom part of the casing contains the board of inputs and outputs containing the battery and back-up battery and terminal box for connecting the pressure and temperature sensors and any device inputs and outputs. The connections related to the metrology function of the converter are protected by covers which are secured with official mark.

Optionally, the input board can have an extension board for connecting an additional digital pressure (EDT 23 type) or temperature (EDT 34 type) converter. This additional digital converter communicates with the converter using the protocol Modbus RTU interface RS-485.

Note:

If SCR encoder is required it can be arranged only by manufacturer or by authorised service center. Those two subjects will ensure appropriate labelling placed on housing.

The lid of the housing contains a processor board which is protected by a cover and secured by an official mark. The board cover has an opening for access to the service switch. The service switch can be used to enable/disable the setting of the device parameters using a service SW.

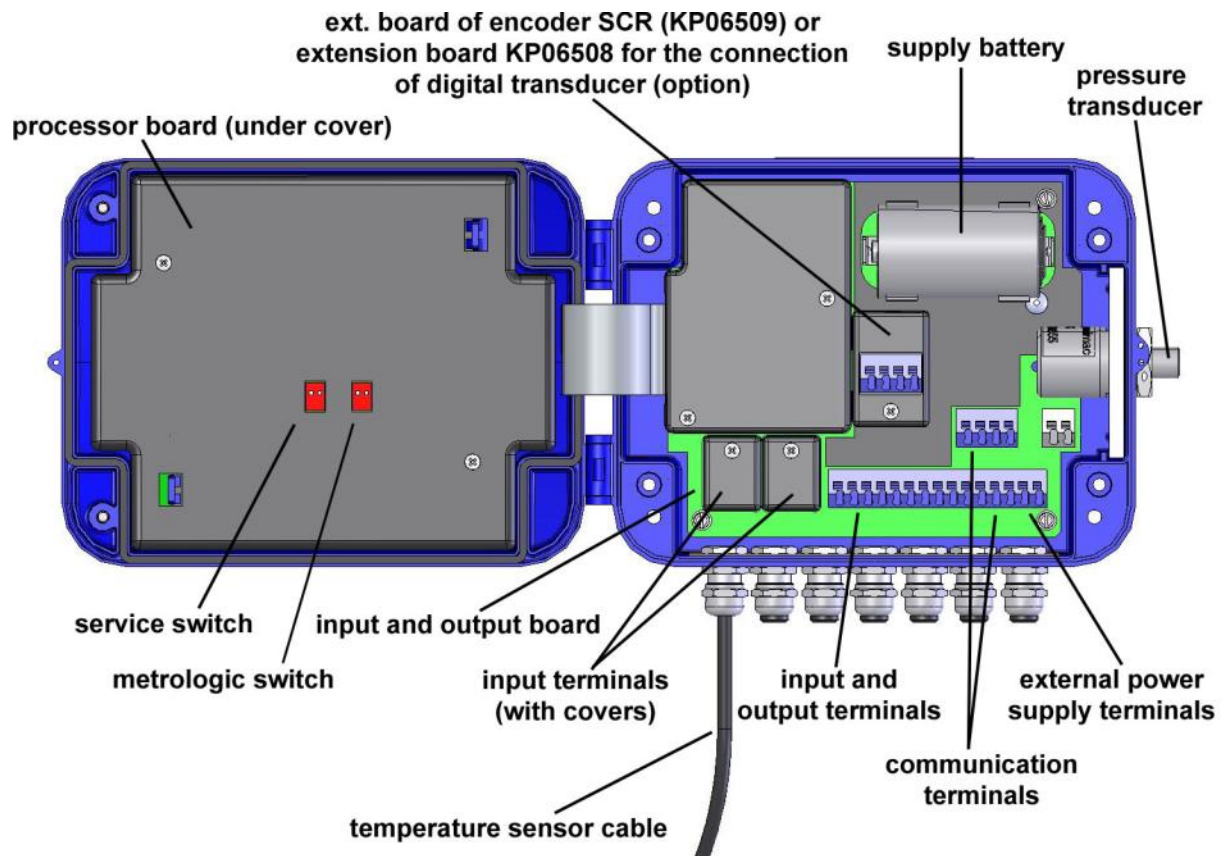

Fig. 3 Main parts of the device

2.2 Device power supply

2.2.1 Supply battery

The device is powered by a built-in battery (lithium) with a voltage rating of 3.6 V. The life cycle of the battery depends especially on the configuration of the device, the frequency of communication, and the time the display is on. The consumed capacity is calculated during the device's activity and the capacity decrement is recorded in its memory. The device will issue an alert to replace the battery 90 days before the expected discharge (error messages **E9** – see Table 8).

Defined mode with life cycle of the supply battery of more than 5 years:

- Archiving period of the data archive 1 hr
- Communication with device 2 min/day
- Showing on the display 2 min/day
- Period of input impulses ≤ 10 Hz
- Measuring period 15 s
- Surrounding temperature 25 °C
- expansion board KP 065 09 (SCR encoder) is not used

If the device is operated with higher consumption than in the defined mode, it is necessary to count on a more frequent replacement of the battery or use a network power source.

2.2.2 Replacement of supply battery

Replacement of battery is allowed also at hazardous zone but only with recommended type of battery.

. It is suitable to disconnect the discharged battery as soon as possible. While the battery is being replaced, the device does not measure pressure or temperature, but counts the incoming If impulses (but does not convert the number of pulses, this will be performed only when the supply battery is connected again) and insures that the real time clock is running. The data stored in the device archives and parameter settings will remain preserved.

Due to correct calculation of remaining battery capacity after replacement it is mandatory to reset this information with service SW tool [22].

Discharged batteries belongs at hazardous waste category. According to OEEZ (2002/96/ES) directives and and other internal directives battery must not be disposed together with household waste. Withdrawing duty is applied over discharged battery.

2.2.3 Back-up battery

The battery ensures the back-up of important functions in case of discharge or replacement of the supply battery. The back-up battery can be replaced in an accredited service center after the official and security mark is broken (replacement can not be performed in a potentially explosive atmosphere). It is necessary to use the same type of battery. Only recommended type of battery may be used.

Defined mode for life cycle of back-up battery of 10 years

- Storing, temperature 25 °C
- Backed-up inputs (DI1 – DI4) not connected or connected contacts disconnected
- Does not depend on the presence of the supply battery

Defined mode for life cycle of back-up battery of 4 years

- Backed-up inputs (DI1 – DI4) short-circuited
- Without powering battery

Self-discharging of batteries

The back-up and supply batteries are lithium. Their capacity drops due to self-discharging. The recommended time frame for their replacement is 10 years, even if the battery was never connected.

2.2.4 External power supply

Usage of external power supply is **necessary** in case of appliance of:

- NAMUR HF pulse input
- Binary output
- NAMUR encoder.

External power supply is **recommended** in case of increased current consumption regimes like:

- frequent communicationi (more than once a day),
- frequent LCD displaying
- SCR encoder usage.

An approved intrinsically-safe source must be used for the external power supply. In case a NAMUR type sensor is not connected to the device, one can use the built-in sources of the communication modules DATCOM-Kx or sources JBZ-01, JBZ-02.

If the NAMUR sensor is connected to the device, one must always use an external power source JBZ-01 or JBZ-02.

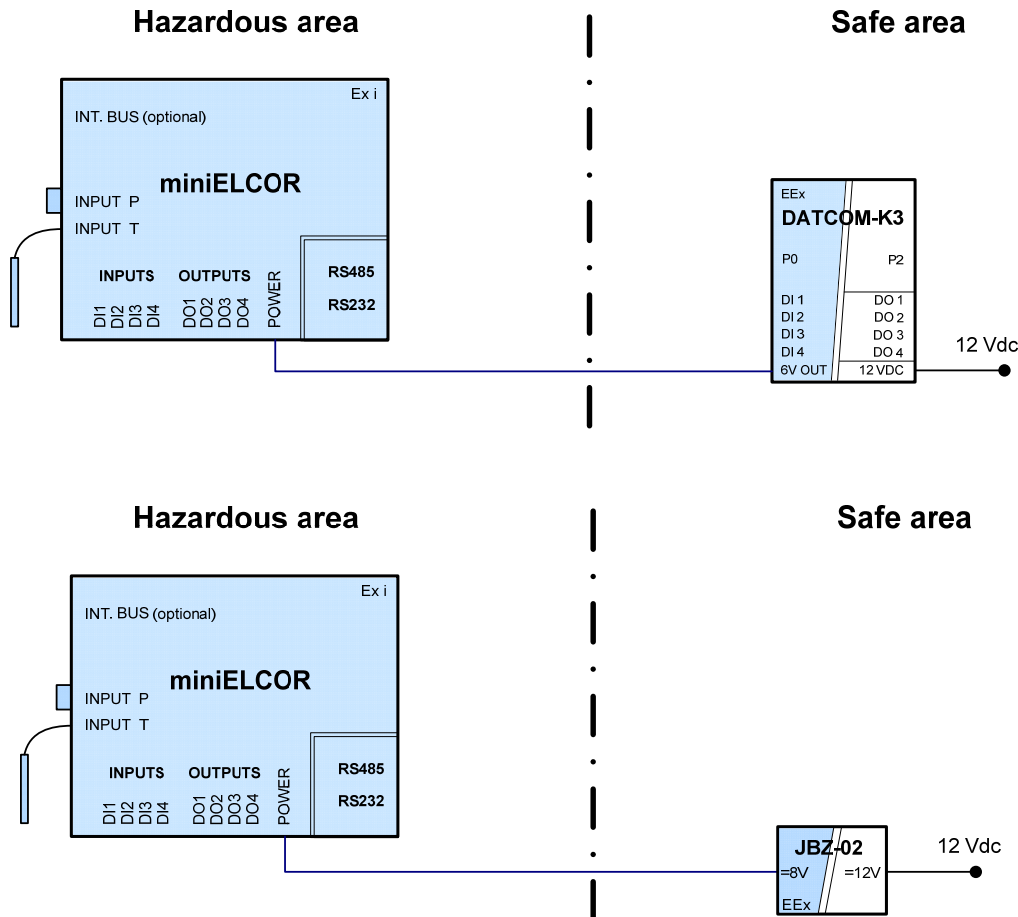

Fig. 4 Examples of external power supply

2.3 Security marks

Security marks located on the device indicate the technical condition of the device regarding unauthorized handling.

Security mark of the manufacturer (metrology mark)

- its design is stipulated by the Approval certificate on the quality management system for production, output control, and testing pursuant to Enclosure no. 2, procedure D, ND no. 464/2005 Coll., issued by the Notified person no. 1383. Such security mark has the same importance for the user as the so called Official mark pursuant to the Act on Metrology.

In case such a mark is broken, the manufacturer does not guarantee that the properties of the device are in compliance with the EC Certificate on type verification.

User mark

- control mark of the user (seals) as needed

Mark of manufacturer

- control mark of manufacturer as needed

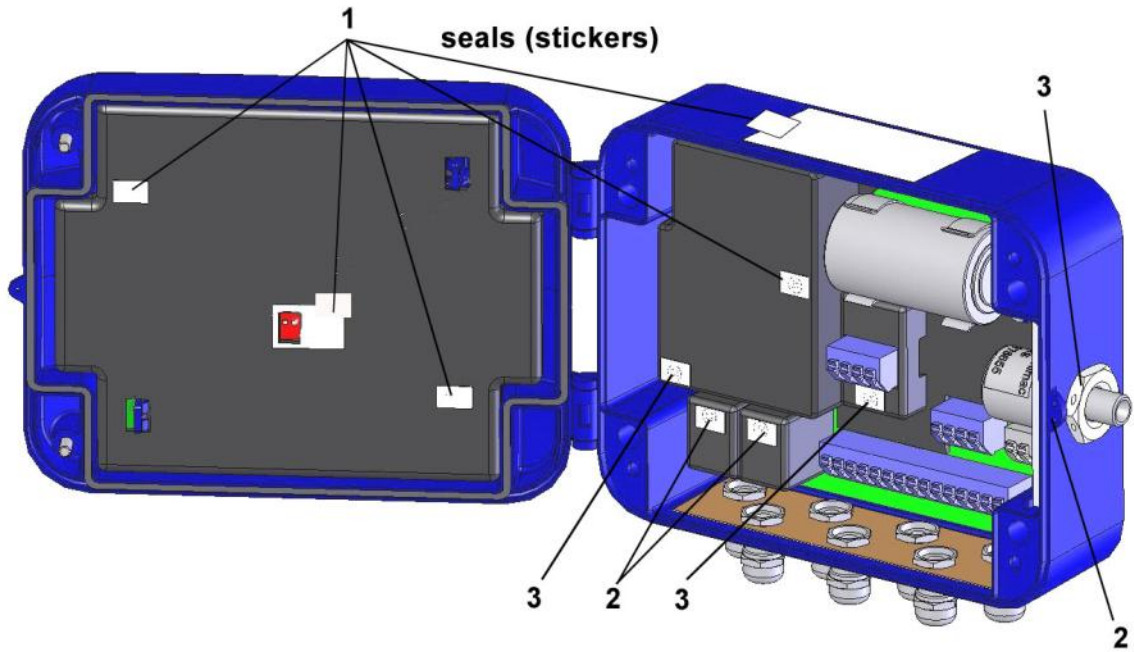

- 1 - Security mark
- 2 - User mark
- 3 - Mark of manufacturer

Fig. 5 Security marks (device without SCR encoder)

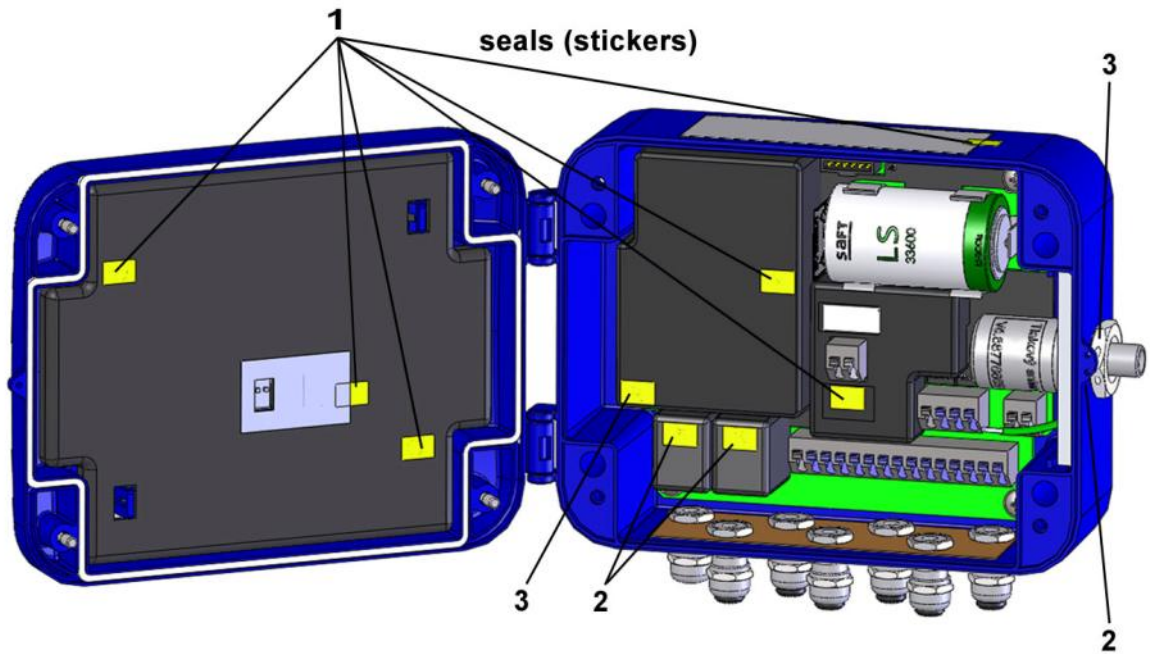

- 1 - Security mark
- 2 - User mark
- 3 - Mark of manufacturer

Fig. 6 Security marks of miniELCOR SCR

2.4 Product label

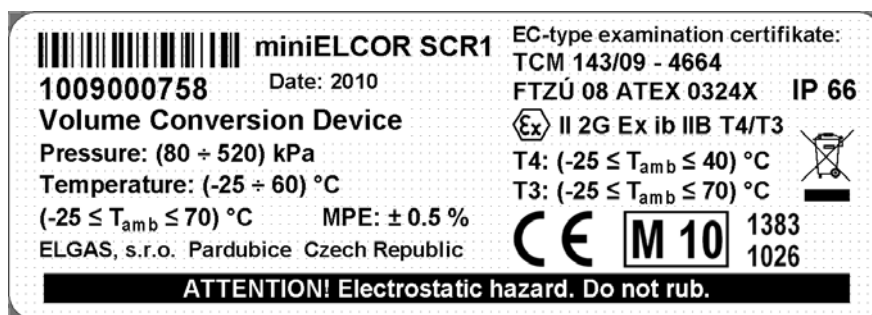
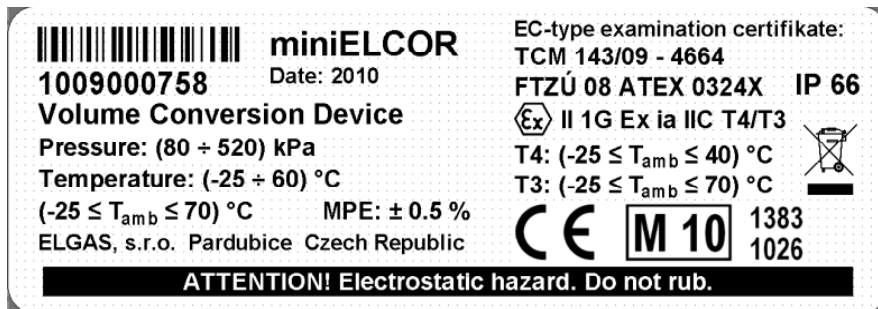

Fig. 7 Product label English version

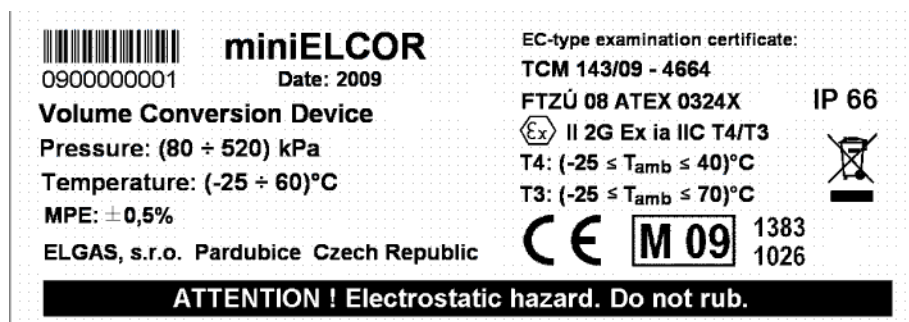

Fig. 8 Product label – original certification for ZONE 1

3 Safety instructions

3.1 General

The device has been approved pursuant to the guideline 94/9/CE and an EC certificate on type verification (ATEX) has been issued for its use in potentially explosive atmospheres. Respecting this guideline is included in the CE compliance notation.

3.2 Use in potentially explosive atmospheres

Based on the EC certificate in type verification 08 ATEX 0324X, the device can be operated in potentially explosive atmospheres with a classification of ZONE1 (potentially explosive atmosphere during normal operation) and ZONE2.

Device is fully in compliance with EN 60079-26 ed.2 (viz [4]) and ATEX approval 08 ATEX 0324X was extended by Supplement n.3 for hazardous **ZONE 0**.

Indication of the device regarding safety against explosion:

II 1G Ex ia IIC T4/T3	miniELCOR	Zone 0
II 2G Ex ib IIB T4/T3	miniELCOR SCR	Zone 1

Environment temperature for temperature class T4: -25 °C to +40 °C

Environment temperature for temperature class T3: -25 °C to +70 °C

The entire device has been constructed and approved as intrinsically safe. That means that only approved devices (intrinsically safe devices, consecutive devices) or so called simple devices complying with the EN 60079-11 standard and complying with the intrinsically safe parameters listed in the EC Certificate on verification type [16] can be connected to the device connectors.

The pertinent safety standards must be met when connecting.

When connecting a device, it is necessary to consider the electrical characteristics of the connecting cables and abide by the requirements of the pertinent safety standards. Furthermore, it is necessary to abide by the Special conditions of use provided these certificates contain them. The parameters of non-explosiveness of the device are listed in 13.

3.3 Risks of usage

Device cabinet is produced from polycarbonate material. Foil keypad of polystyrene is placed on top cover. In some extreme cases electrostatic charge accumulated on surface of cabinet could cause explosion. To avoid explosion it is strictly recommended to keep the following rules:

- At hazardous zones device must not be installed at places where outer conditions could create an electrostatic charge.
- Device may be cleaned by humid wiper.

3.4 Special conditions of use

1. The device must not be installed and located in an environment with a potential danger of electrostatic charge of the device casing (e.g. by flowing air, etc.) Only a damp cloth must be used if the device is being cleaned, to prevent from creation of electrostatic charge.
2. Only the following types of supply batteries are admissible in the device: Saft LS33600, Saft LS14250.

3.5 Using device variants for different groups of gas

Individual variants of device can be used only with certain groups of gas according to this table.

Group of gas Device variant	IIC	IIB	IIA
	miniELCOR	yes	yes
miniELCOR SCR	no	yes	yes

4 Metrology characteristics

4.1 Measuring temperature

This device uses the PT1000 temperature sensor to measure temperature. The temperature sensor's connection is two-wired. The influence of the length and the characteristics of the cable used are considered during calibration and therefore do not influence the accuracy of the temperature measuring.

The temperature measuring range is -25 °C to +60 °C. The measuring period is common for both the measuring of temperature and pressure and it can be custom set at a range from 1 s to 30 s. The temperature measuring units can be adjusted.

Replacement of the temperature sensor is protected by the security mark of the manufacturer (metrology mark) and can be performed solely at an Accredited Service center (ASC).

During device configuration, the user must enter the constant parameter **Default temperature value**. This value will be used for the calculation of compressibility instead of the measured temperature value in the following cases:

- The value of the measured temperature deviated from the measuring range
- An error occurred when measuring the temperature

4.2 Measuring pressure

Pressure measuring is ensured by an analog converter. The converter contains a piezoresistive silicon sensor with a resistant stainless steel membrane. The device electronics ensures the correction of non-linearity and the temperature dependency of the pressure sensor based on the calibration data saved in the device memory. The measuring range of the pressure converter must be requested by the customer when ordering the device. The available pressure ranges are listed in chapter 12.

The measuring period is common for both the measuring of temperature and pressure, and can be custom set at a range from 1 to 30 s. The pressure measuring units can be set.

Replacement of the pressure converter is protected by a security mark of the manufacturer (metrology mark) and can be performed solely at an Accredited Service center (ASC).

During device configuration, the user must enter the constant parameter **Default pressure value**. This value will be used for the calculation of compressibility instead of the measured pressure value in the following cases:

- The value of the measured pressure deviated from the measuring range
- The device is manufactured without the pressure converter (so called TZ or T corrector)
- An error occurred when measuring the pressure

4.3 Compressibility calculation

4.3.1 PTZ, TZ conversion

The compressibility factor is calculated from the composition of the gas listed in the parameters, using one of the following methods implemented in the device: AGA NX-19-mod, SGERG-88, AGA8-G1, AGA8-G2 or AGA8-92DC.

Calculation of the compressible factor is performed in each measuring period. In the SGERG-88 and AGA8-G1 methods the value of the heat of combustion is entered for the combustion temperature 25°C / gas temperature 0°C. The service SW contains a built-in calculator for the conversion of the heat of combustion at different temperatures.

Due to the required accuracy of the device, the use of the individual methods of calculation of compressibility is limited by the pressure and temperature ranges pursuant to the following table:

Pressure measuring range	Method			
	AGA NX-19 mod	SGERG-88	AGA8-G1 AGA8-G2	AGA8-92DC
80 ÷ 520 kPa	-25 ÷ +60 °C	-25 ÷ +60 °C	-25 ÷ +60 °C	-25 ÷ +60 °C
200 ÷ 1000 kPa	N/A	-25 ÷ +60 °C	-25 ÷ +60 °C	-25 ÷ +60 °C
400 ÷ 2000 kPa	N/A	-25 ÷ +60 °C	-25 ÷ +60 °C	-25 ÷ +60 °C
700 ÷ 3500 kPa	N/A	-10 ÷ +60 °C	-10 ÷ +60 °C	-25 ÷ +60 °C
1400 ÷ 7000 kPa	N/A	-10 ÷ +60 °C	-10 ÷ +60 °C	-25 ÷ +60 °C
80 ÷ 1000 kPa	N/A	-25 ÷ +60 °C	-25 ÷ +60 °C	-25 ÷ +60 °C
400 ÷ 7000 kPa	N/A	-10 ÷ +60 °C	-10 ÷ +60 °C	-25 ÷ +60 °C

Table 1 Limitation of standard validity range of compressibility calculation

Note:

At device there is applied compressibility calculation method GOST NX-19 which is not approved by ČMI certificate.

Usage of method GOST NX-19 is limited only for temperature range from -23°C to +60°C.

Default compressibility

For the set method during each calculation, it is checked whether the measured pressure and temperature value are in the valid interval of the pertinent method. If some of the values are outside the valid interval, the so called default compressibility is used for the conversion. The value of the default compressibility must be entered by the user during device configuration.

4.3.2 PT, T conversion

The device also allows the setting of the ratio of compressibility factors (K) as a fixed constant. The range of the entered constant is not limited.

4.4 Volume measuring and calculation

For measurement and volume calculation there are used following counters for each channel.:

V_m	-	Primary volume counter
V_c	-	Corrected volume counter (volume corrected based on gasmeter correction curve)
V	-	Volume V_m or V_c
V_s	-	Counter of the operational volume at error conditions (error operational volume)
V_b	-	Counter of volume at base conditions (standardized volume)
V_{bs}	-	Counter of standardized volume at error conditions

4.4.1 Operation at error conditions

In case of the occurrence of error conditions, the device, at the same time as counting the impulses in the counter of the volume at measuring conditions (V), starts to count the impulses in the counter of the error volume at measuring conditions (V_s). The values of the volumes at base condition (V_b) will stop being counted in the counter of the volume at base conditions (V_b), and will be counted from the default values of pressure or temperature and will be stored in the counter of the error volume at base conditions (V_{bs}). During this condition, the values are not stored in the counter of volume at base conditions (V_b).

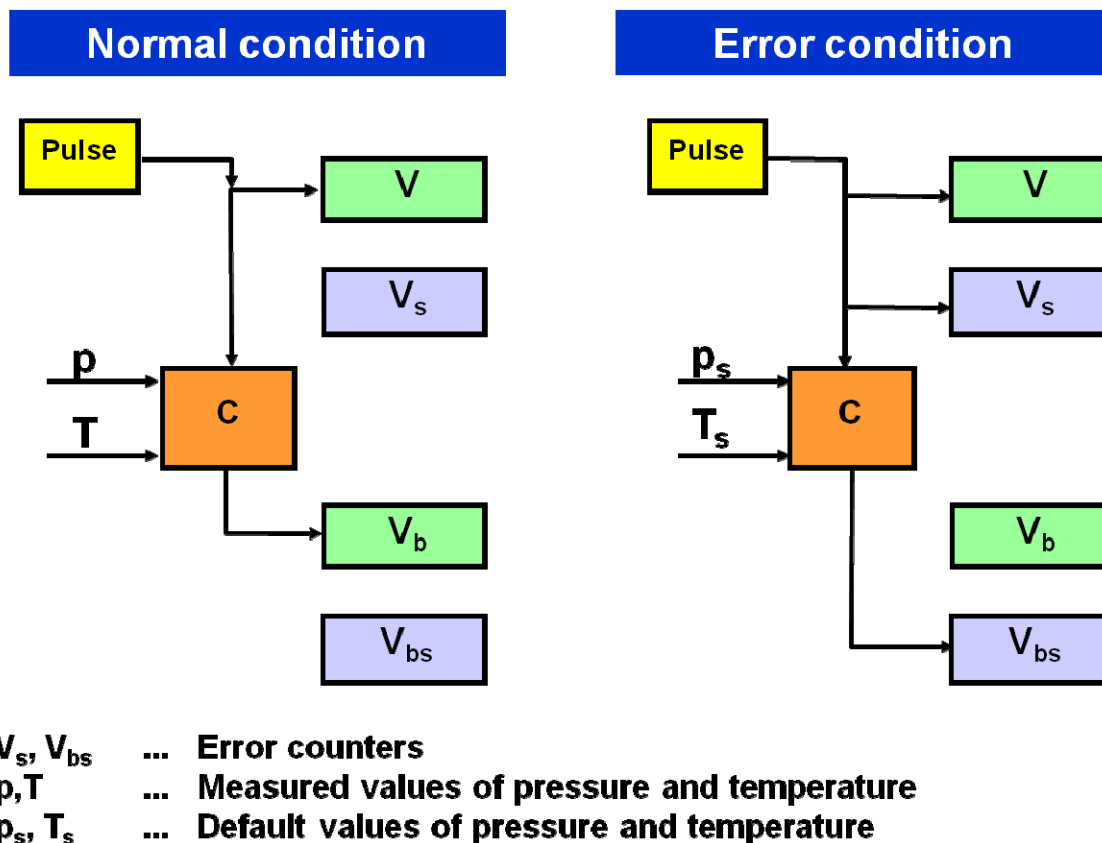

Fig. 9 Storing impulses in counters

If a default compressibility is used during the calculation for the reason of deviation of accuracy for the set calculation standard outside the allowed value (see article 4.3.1), whereas p or t are not outside the measuring range, the converted volume is stored in the error counter.

If corrected volume V_c is used primary volume counter can be linked to V_m or V_c at error conditions..

4.4.2 Recognition of gas flow direction change of gas meter (*)

Flow direction detection is enabled for gasmeter equipped with two phases shifted LF sensors or encoders. Both ways are approved for custody transfer at EC type approval amendment. Corrector evaluates gas flowrate respecting direction changes (Pict. 9) under following terms:

- If primary volume additions are positive in such case volume processing is made by standard procedure (for example increasing of V_m and V_b , or V_{ms} and V_{bs}).
- If gas flow direction is changed device will fix the value of primary volume counter at the moment of turn. When gas flows back only primary volume V_m (or V_{ms}) is updated. The other counters are frozen.

- After returning back to correct direction counting will get blocked out into appropriate counters (V_b , V_{bs}) only after reaching level of primary volume where reversed flow was started up. Primary volume counter is equivalent to gasmeter counter all the time.

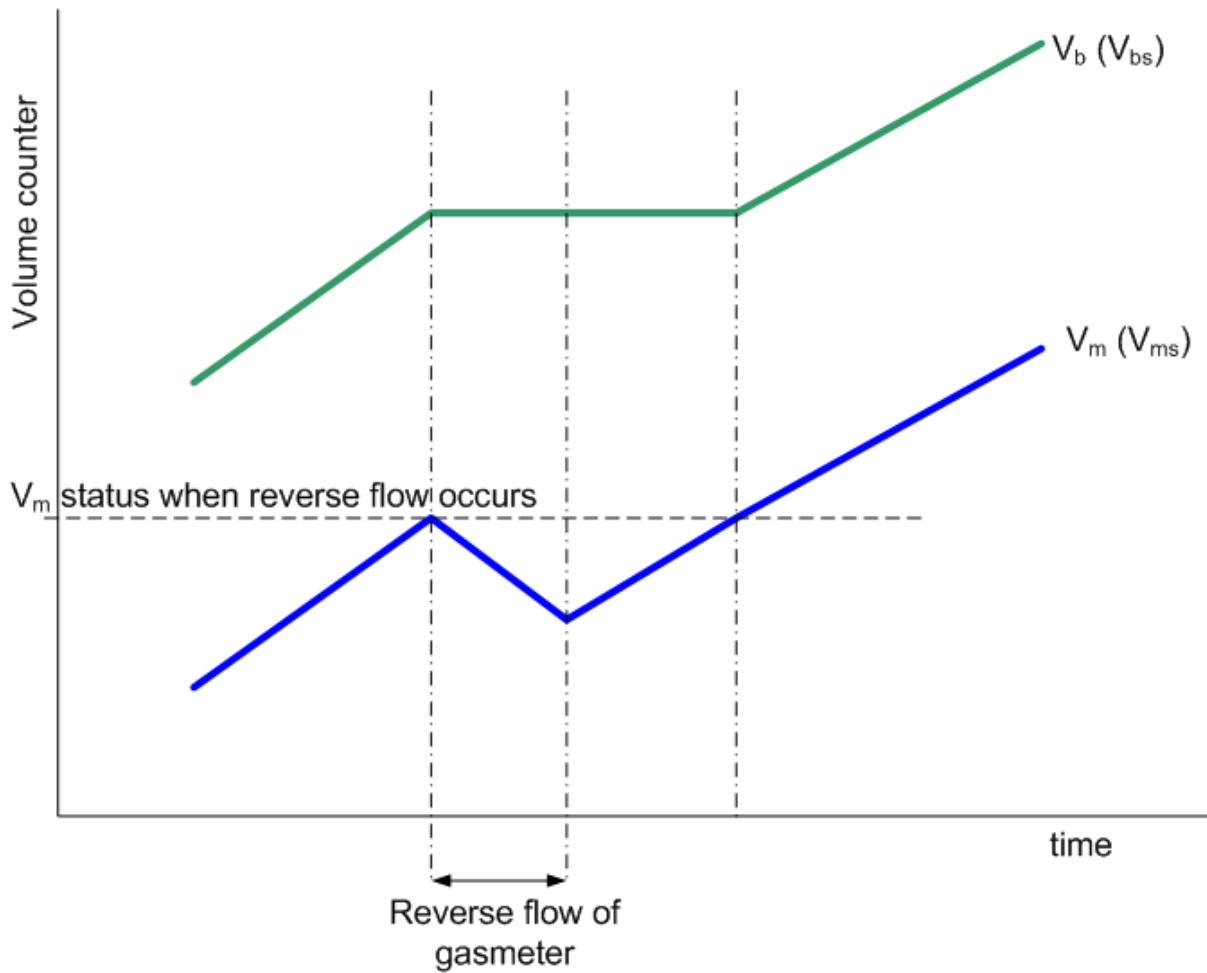

Fig. 10 Processing of volumes during reversed flow

5 Connecting inputs and outputs

5.1 Inputs

A total of 4 digital inputs marked as DI1 to DI4 can be connected to the device. The inputs are brought out at the terminal board inside the device. The digital inputs can be adjusted using the service SW as a binary or as a LF impulse. The DI1 and DI2 can also be set as HF impulse or binary type NAMUR. In devices with FW ver. 4.xx input DI1 may be setup also for connection with NAMUR encoder

Input	Binary contact	Binary NAMUR	LF impulse	HF impulse	encoder NAMUR
DI1	√	√	√	√	√
DI2	√	√	√	√	-
DI3	√	-	√	-	-
DI4	√	-	√	-	-

Table 2 Digital inputs setting options

5.1.1 LF impulse inputs

Serves to read impulses from a gas meter. The flow measuring function can be chosen for these inputs. The back-up battery ensures preservation of counters' conditions and reading the impulses of the LF inputs also in case of the discharge or replacement of the supply battery. After connection of the supply battery, the impulses read during the outage of voltage of the supply battery are added to the error counters. The LF impulse input is, on the DI1 and DI2 inputs, connected between the terminals LF+ and LF- (see Fig. 12).

Changing measuring units, setting the gas meter constant

The measuring units of the impulse inputs can be changed using the service SW [22]. The conversion constants of the gas meter and S/N of gas meter can be set using the service SW as well as directly from the device keyboard. When setting the value of the gas meter constant, only decimal folds or fractions in range from 0.01 to 100 are expected.

Number of places of counters of lf impulse inputs

In the case of lf impulse inputs, the counter works with 9 valid digits, the gas meter constant influences the size of the maximum number from 9 999 999.99 (for constant = 0.01) to 99 999 999 900 (for constant = 100).

5.1.2 HF impulse inputs (NAMUR)

The inputs DI1 and DI2 can be configured for processing HF impulses from the sensors of type NAMUR. Due to the fact that these sensors require a supply voltage higher than the voltage of the supply battery of the device, the converter must have an external supply voltage higher than 7 Vdc (e.g. from JBZ-02) for the registration and processing of HF impulses.

The flow measuring function can be chosen for these inputs. The back-up battery ensures the preservation of counters' conditions in case of an outage of the external supply even in the case of discharge or replacement of the supply battery,

but it does not ensure the counting of the impulses. The terminals for the HF NAMUR inputs are marked HF+ and HF- (see Fig. 12).

Changing measuring units, setting the gas meter constant

The impulse inputs measuring units and the gas meter constant can be adjusted using the service SW. The gas meter constant and S/N of gasmeter can be also set from the device keyboard.

Number of places of counters of the hf impulse inputs

In the case of hf impulse inputs, the counter works with 9 digit places.

5.1.3 Connection with gasmeter via encoder (*)

Gasmeter can be connected with corrector via encoder. Digital value of gasmeter counter is transferred into EVC. Two types of encoders are supported like NAMUR and SCR.

The usage of encoders is approved for metrological reasons by EC- type certificate TCM 143/06-4664, Adition 1.

Encoder NAMUR

No special HW is required for NAMUR encoder usage. The only condition for NAMUR encoder data processing is usage of IS external power supply JBZ-02 (or JBZ-01).

Encoder SCR

To process data from SCR encoder miniELCOR SCR type must be used complemented with KP 065 09 board. This board must be complemented directly only by manufacturer. Additional assembly at customer side is not allowed. Encoder board is connected with input board via IS RS485 Bus (there is used connector dedicated for digital transducer connection (see Pict.3 and Pict.4). This type of encoder can be also used for only battery powered EVC but it is too much energy consuming. Enduser should take care about it during parameterisation.

5.1.3.1 Encoder NAMUR input

Connection between EVC and encoder is made with shielded two wires cable. NAMUR encoder may be connected only via digital input DI1. Terminals for encoder are the same like for HF pulse input marked HF+ and HF- (correct signal polarity is important.). NAMUR encoder connection must be setup in EVC parameters with SW Telves 22.

5.1.3.2 Encoder SCR input

Connection between EVC and encoder is made with shielded two wires cable via terminals marked A and B board SCR (KP065 09). No matters on conductor polarity. Encoder data are transferred into EVC at default measurement period. The shorter measurement period has bad impact on battery life.

If SCR encoder is used at battery regime at standard 30s measurement period battery life will be decreased down to 2 years.

5.1.3.3 Device specification with encoder

Data from encoder are transferred into EVC via shielded two wires cable. Together with absolute value of gasmeter counter there are transferred other additional data like S/N , gasmeter constant, number of figures nine for counter overturning). These additional data are read out with service SW 22 usable at device parametrisation.

In case of error at communication between EVC and encoder then:

- At actual value primary volume is displayed with asterisk symbol “ * “ .



- If error of communication is longer than 10 min there is volume difference added into estimated volumes immediately after restart of communication.



Fig. 11 Encoder SCR board (without cover)

Manual setup of primary volume counter V_m is not allowed at encoder input..

Installation and replacement of gasmeter

Actual counter of gasmeter is transferred into EVC after connection of encoder and EVC possibly causing big difference at primary volume V_m . To prevent against affection of base volume V_b (V_{bs}) it is necessary to keep following instruction:

1. In service SW 22 display device parameters, select subject „Encoder SCR“ and push button „Encoder exchange“. During encoder exchange will be stopped processing of primary volume from gasmeter. (Further follow instructions shown on PC display).



2. Connect physically encoder to EVC.
3. After connection of encoder finish installation/exchange with OK button.

During installation/exchange (meant from point 1) no differences are added to appropriate counters which are marked on display with exclamation mark. If point 3 is not finished by one hour exchange procedure will be closed automatically at service SW.

5.1.4 Binary inputs

These inputs monitor the input signals with the option of an evaluation of the condition “connected” (i.e. log. 0) or “disconnected” (log. 1). The device allows the evaluation of the binary inputs from the no-potential outputs (reed contact or open collector – these signals are on DI1 and DI2 inputs connected to terminals LF+, LF-) or from sensors of the type NAMUR (DI1 and DI2 inputs, terminals HF+, HF-) The NAMUR sensors require an external supply voltage of the converter higher than 7 V (e.g. from JBZ-02).

By setting the parameter, the user can choose the display of the instantaneous values on the display, storing the changes of these inputs in the archive; display the headline for condition log. 0 and log. 1, and active signal level.

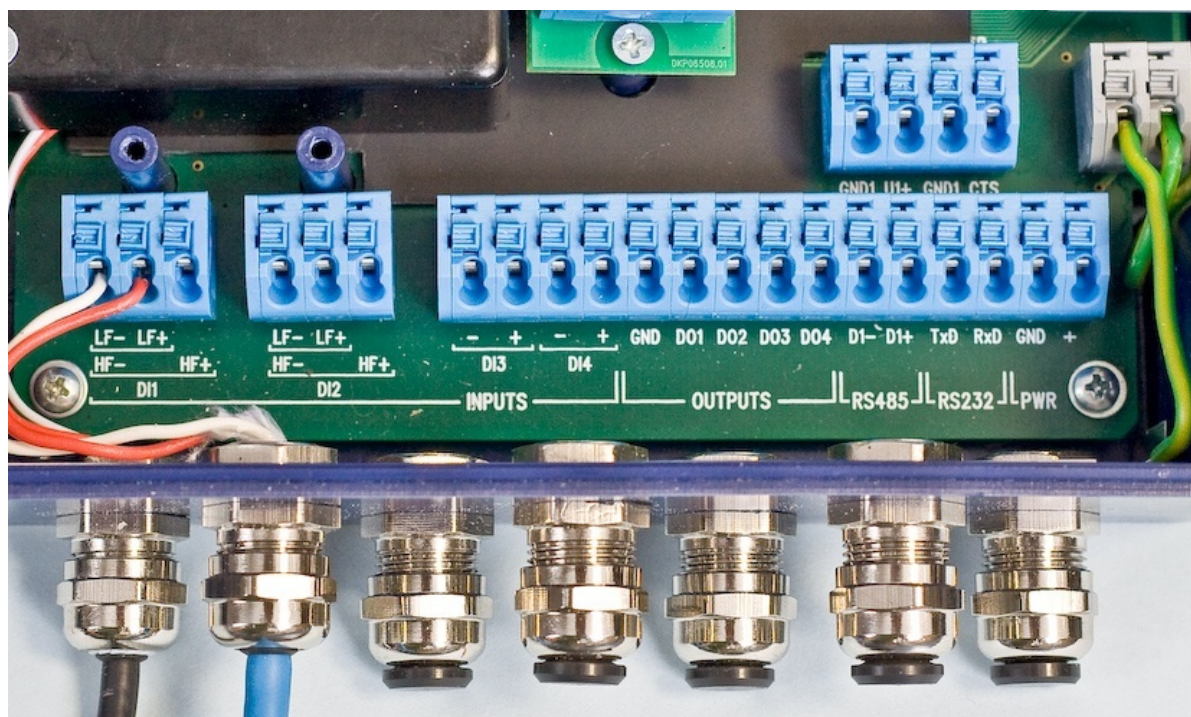

Fig. 12 Inputs and outputs terminals

5.2 Outputs

The device has 4 digital outputs DO1 to DO4 which can be configured as binary, impulse, or data. A data output serves for the realization of an analog output 4-20 mA using the CL-1 module which is connected to this output.

The outputs can be controlled by the device using the calculation equations entered by the user in the device parameters (for example, it is possible to generate outputs according to the volume of the gas flown through, indication of alarm condition, exceeding the set limits of pressure or temperature, etc).

The device structure allows the generation of outputs even when the device is powered solely by the battery with no effect on the battery life cycle. The outputs are “open collector” type and are not galvanic separated. All four outputs have a joint GND conductor.

The outputs are intrinsically safe, thus when connecting standard devices, the devices must be connected via a safety barrier (e.g. DATCOM-K3, see Fig. 13).

Impulse outputs

The impulse outputs have adjustable width and impulse periods in folds of 0.1 s. The debt of impulse outputs can reach max. 65535 pulses. An output constant can also be realized in the setting equation of the output quantity.

Binary outputs

Output terminals are according to the output quantity in the connected or disconnected condition. In the resting state, the output terminals are disconnected (condition log.1).

Data output

The digital output configured as a data output serves for communication with the CL-1 module. An analog output 4-20 mA can be realized using this module.

Using the calculation equations, the value of the output can be parameterized as proportional to pressure, flow, daily consumption, etc. The CL-1 module must be connected to the converter via a safety barrier (DATCOM-K3).

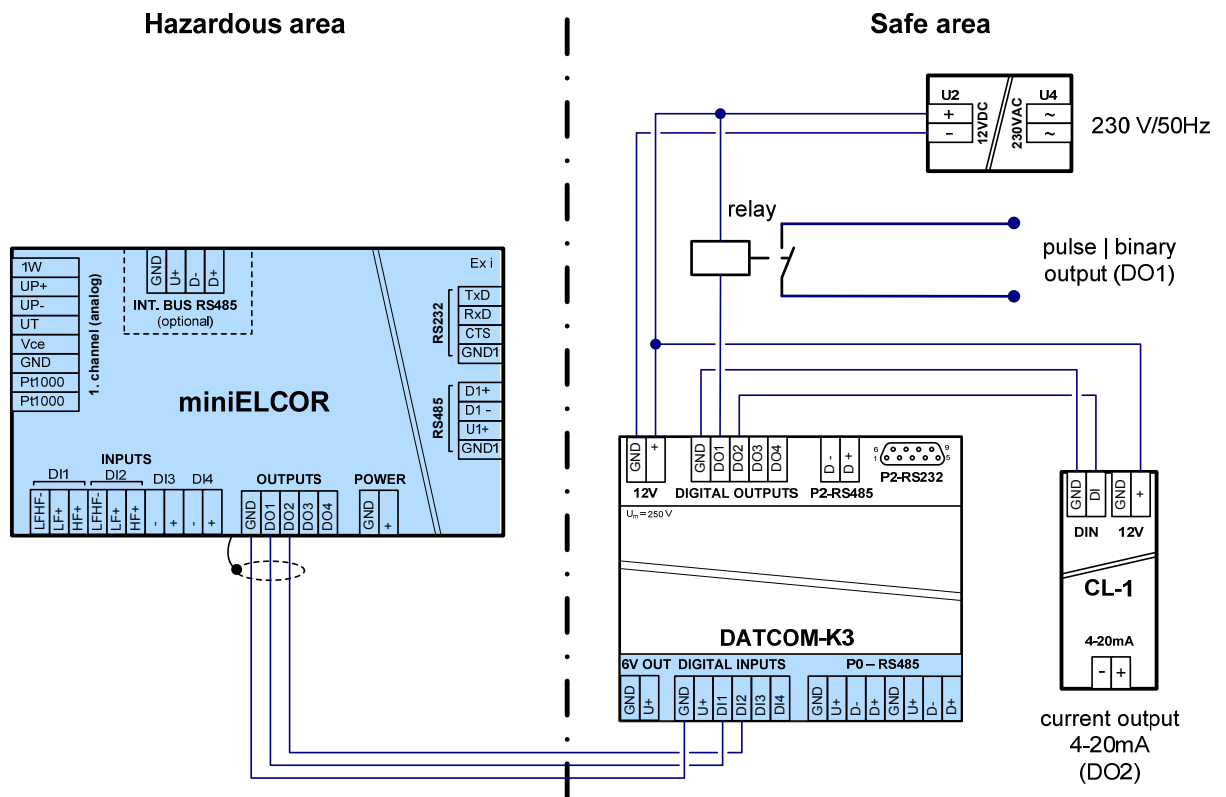

Fig. 13 Example of an impulse (binary) output and current output scheme

5.3 Adding of another pressure or temperature transducer

Beyond standardly mounted pressure and temperature transmitters which are metrologically approved according to EC-type certificate it is possible to add additional pressure or temperature transducer.

This extension is **not possible** for devices already equipped with expanding SCR encoder board.

Quantity measured by this additional pressure or temperature transducer is not metrological value. It means that it is not included in to the metrological part of the device. Measured values is possible to store in to the archives and also show actual values on the display.

As additional transducer can be used either digital pressure transducer EDT 23 or temperature digital transducer EDT 34. Digital transducer is using for communication internal intrinsically safe serial bus RS-485 and MODBUS RTU

protocol. On account of intrinsic safety must be connected transducer intrinsically safe - "ia" type. Type of the transducer is necessary to specify in time of order.

For connection of additional digital transducer (EDT 23, EDT 34) must be volume corrector equipped with expansion RS-485 module (KP 065 08) (see Fig. 15). Expansion module RS-485 and additional digital transducer there are not part of standard accessories and it is necessary to order it separately. Module RS-485 can be ordered additionally and by this way expand already installed device.

Digital transducer is connected to the RS-485 clamps of expansion module. Only one digital transducer can be connected to the expansion module. Connecting/disconnecting of transducer and also of RS-485 module can be done only when power supply is disconnected.

Procedure of connecting expansion module RS-485 and digital transducer

1. Disconnect volume corrector from external power supply (if present)
2. Open the device and remove battery
3. Unscrew plastic cover of input/output board in place of plugging expansion module RS-485 (factory seal will be breached)
4. Insert expansion module in to the X4 board of inputs. After inserting of the module there it is necessary to check if some connector pin is not out of the contact tube. All pins must be inserted in to the connector properly
5. Apply cover delivered with the expansion module and screw the expansion board with input/output board
6. Connect digital transducer. Cable of the transducer pull through the cable bushing. Shielding of the cable attach with body of the bushing. Electrical scheme of connecting expansion module RS-485 is shown on Fig. 14.
7. Check digital transducer connection
8. Connect device back to the power. It is inserting of battery and external power supply connection (if present)

After installation of digital transducer it is important to add it in to the parameters by the help of service software (see paragraph 17).

Expansion module RS-485 for digital transmitter connection

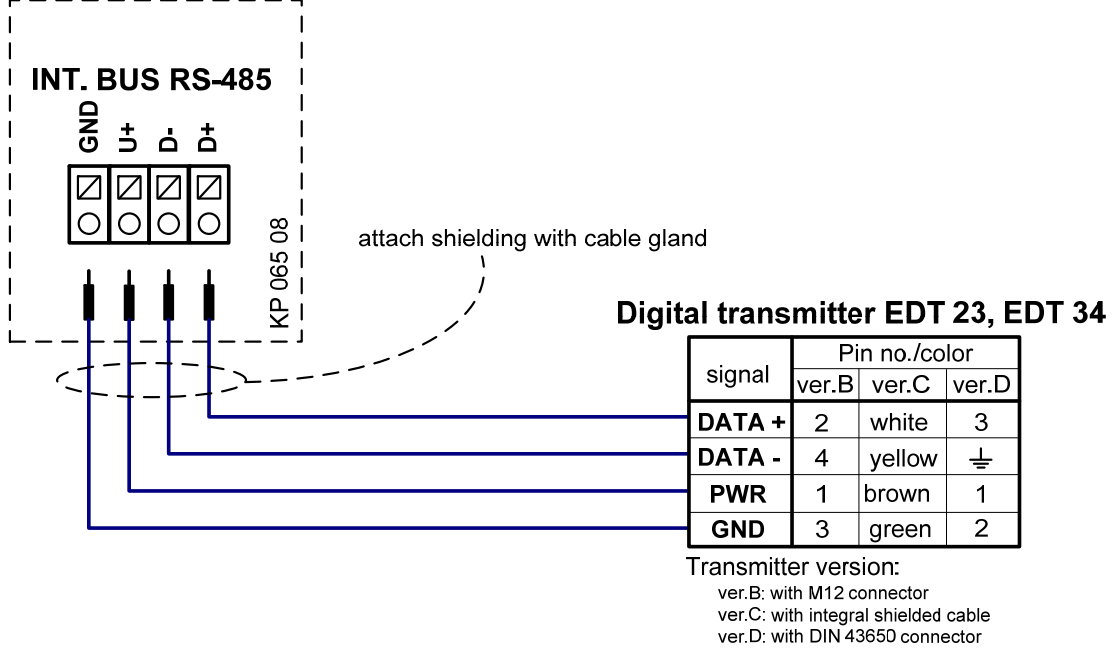

Fig. 14 Connecting of digital transducer with expansion module RS-485

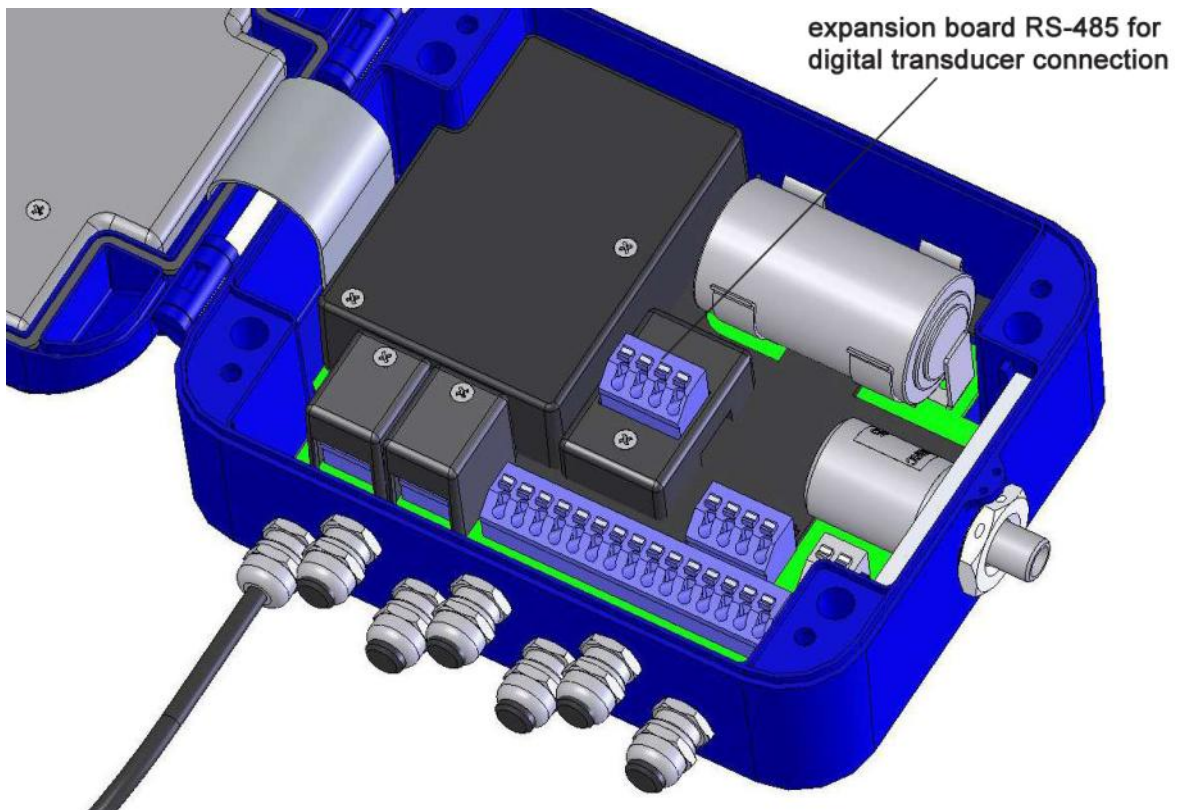

Fig. 15 Placing of expansion module RS-485 in the device

6 Communication with device

For communication with other devices, the device is equipped with one communication channel which brings it to a total of three communication interfaces. Either the communication interface RS-232 or the RS-485 can be used for connection with a superior system. The optical interface is designed for operative readout or device settings.

In the current firmware version, the device is equipped with several communication protocols. The device is prepared for extension by other protocols as required by the customer. The standardly implemented protocols are ELGAS ver.2 and MODBUS RTU. Preset communication protocol is the same for all communication interfaces. It is possible to change communication speed for metallic interface and for optical interface independently.

The ELGAS ver.2 protocol is the native protocol of the device. A complete set of functions realized in the device is available. The service SW [22] solely uses this protocol – in case it is necessary to switch to other link level, the ELGAS ver.2 protocol is only wrapped in one other link level (a so called “a tunnel”). The ELGAS ver.2 protocol is used as the only one for loading firmware (protected by the metrology mark).

The communication circuits are galvanic separated from other device circuits. Because of the galvanic separation, the communication circuits must be powered from outside, from a connected device (CTS signal in case of the RS-232 interface and U1+ in case of the RS-485 interface).

6.1 RS-232 and RS-485 interfaces

Both interfaces are brought out to the internal terminal board and, although they are simultaneously functioning, only one of these interfaces can be used (connected) for communication at a time. Because both of the interfaces are intrinsically safe, it is necessary during installation to separate the device in a potentially explosive environment from the connected common device (computer, modem, etc.) by a consecutive device (DATCOM-Sx, DATCOM-Kx, MTL 5051 etc.), or use a device with a intrinsically safe design.

The communication speed of the interface (the speed is joint for both interfaces) and the communication protocol can be set in the device parameters.

Communication via modem controlled by AT commands

Basic setting features of a modem for the correct cooperation with the device:

- Sending answer (ATQ0)
- Long format of the sent answers (ATV1)
- Echo disabled (ATE0)
- Automatic pickup (ATS0=1)
- Set firmly serial port communication speed of the modem (e.g. for speed 38400 Bd is command AT+IPR=38400)
- Ensure presence of power feeding on clamp DSR of the modem (by command AT&S0). Clamp DSR is interconnected with CTS clamp of device.

More detailed information must be found in the manual of the used modem.

Communication with GSM and GPRS modems

For the purpose of diagnostics during the modem installation, the device has the option of displaying the information from the modem on the presence and connection to a GSM network, and furthermore information on the signal strength measured by the modem. In the case of a GPRS connection, it is possible to display the IP address.

Compatibility with the Siemens MC35, MC39 modem is necessary for correct function in AT commands:

AT+CREG?, AT+CSQ?, AT+CGDCONT and AT^SGAUTH+CGDCONT.

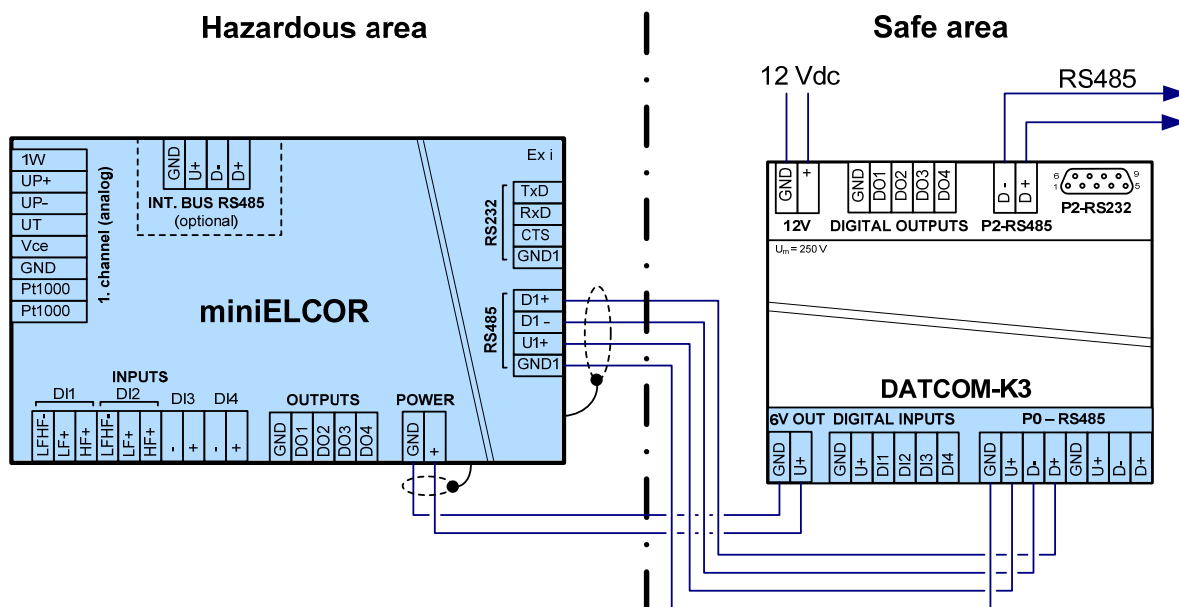

Note: Communication output from DATCOM-K3 can be RS-485 or RS-232

Fig. 16 Safety separation of communication using RS-485 module DATCOM-K3

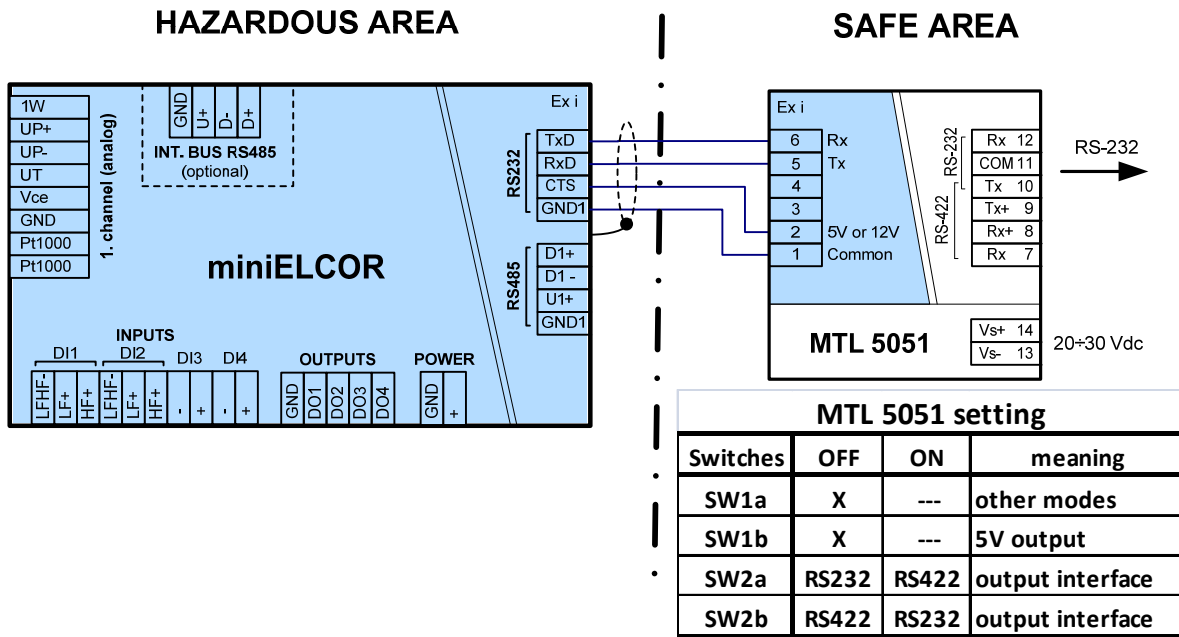

Note: Communication output from MTL5051 can be RS-232 or RS-422

Fig. 17 Safety separation of RS-232 communication via separator MTL 5051

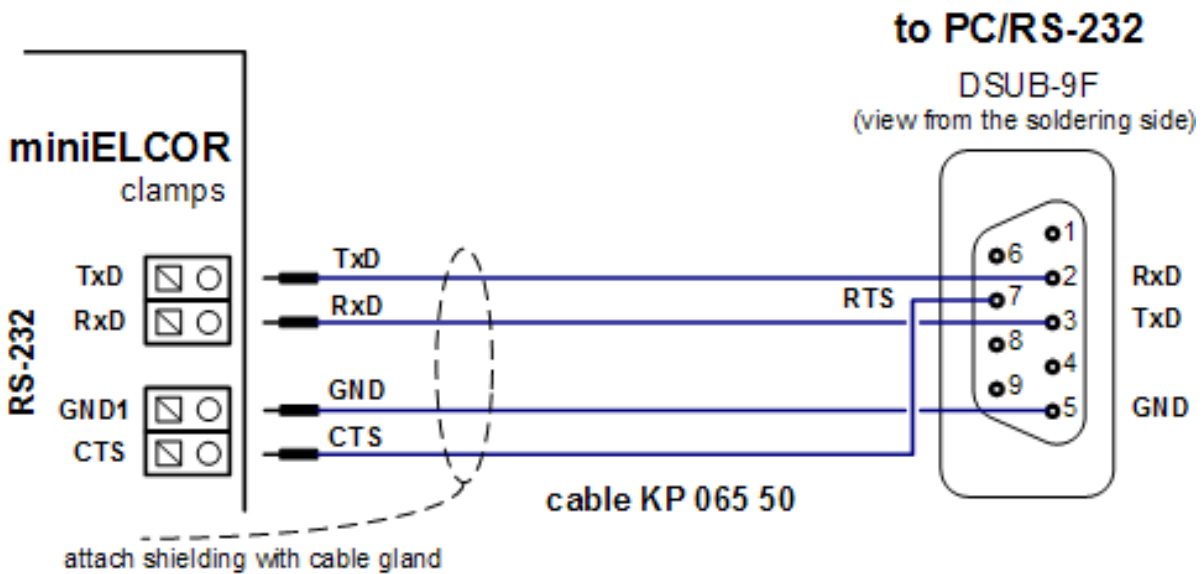

Note: Described connection of EVC with the PC without safety barrier must not be used if the EVC is placed in hazardous area.

Fig. 18 Communication cable wiring

6.2 Optical interface IEC-1107

On the front face of the casing, next to the keyboard, is an optical window for communication using an optical head. The optical head is to be put to the window. It is fixed in place using a magnet. One of the HIE-01, HIE-03, and HIE-04 types can be used as the optical head [13]. After applying the optical head, the device transfers

from the economy mode to the mode in which it is able to accept data. It remains in this mode for 180 s from the last communication (timeout) or until the user takes the optical head of the communication interface.

Warning:

After applying the head, the communication channel from the RS-232/RS-485 device to the optical interface. That means that the communication via the RS-232 or RS-485 is discontinued until the moment the optical head is removed, or until the mentioned timeout from the last communication expires.

The communication speed of the optical interface can be set in the device parameters independently of the speed of the RS-232/RS-485 interface. The setting of the communication protocol is combined for all three interfaces.

7 Description of function

The options of the device regarding displaying the data on the display and storing the quantities are extremely variable and customizable. The user has full control over which quantities will be displayed in the instantaneous values and also which quantities will be stored in the individual archives.

7.1 Measurand marking

For measurand marking there are used symbols defined in table „Used symbols and notions“ (see page 1).

7.1.1 Firmware version FW 4.xx

Measurand marking (*)

- For single channel device at metrological measurands there is not used any index (Index number 1 or 2 is used only for two channels configuration)
- For other types of measurands (nonmetrological) can be used index differentiating the same type of measurands.

User measurand marking (*)

New SW feature enables to user to define own measurand marking. Original marking is considered as default (at service SW 22 is blue marked). Marking must be used in such way to retain definiteness of marking. Definiteness of marking is checked by service SW.

Metrological measurands may be renamed only on ASC level.

User defined measurand marking is used for showing on display and also in service SW and exported for 3rd party SW usage as well.

7.1.2 Version of firmware FW 2.xx

For detailed specification of quantities of the same type (e.g. type “pressure p” etc.), the individual symbols are differentiated by an index (p1, p2, etc.) The following applies for indexes:

- Index 1 is used for all metrology quantities.
- An index with the following value is used for all other quantities (non-metrology). However, if a new type of quantity is used (i.e. a type which has not been used in metrology quantities), the indexing also starts from 1.

7.2 Instantaneous values

For the displayed quantities, the number of the displayed places, units, and the displayed name can be custom set. If the measured quantity is in an error condition, such a condition is indicated by displaying an asterisk at the last position in the line with the quantity name.

Example of quantities which can be displayed as instantaneous values:

- Pressure p
- Temperature t
- Operational volume Vm

- Error operational volume V_{ms}
- Standardized volume V_b
- Error standardized volume V_{bs}
- Flow Q_m
- Standardized flow Q_b
- Conversion factor C
- Compressibility ratio K
- Device error
- External power supply presence
- Battery capacity
- Internal temperature

7.3 Archives

The values are arranged in the archives in time sections, a time data of the section, and values of the individual quantities selected for archiving form a part of each time section.

The measured and calculated quantity values can be stored in the following archives:

- Monthly archive
- Daily archive
- Data archive
- Binary archive
- Limits archive

Besides the listed data archives, the device also contains the following archives:

- Event archive
- Billing archive
- Settings archive
- Gas composition archive

First stored in the available device memory are the archives with a fixed number of records (monthly, daily, binary, and limits) and the data archive is placed in the remaining memory (its length depends on the size of the remaining memory).

	Data archive	Daily archive	Monthly archive	Limits archive	Binary archive
Analog quantities					
Input analog – mean value	yes	yes	yes		
Internal analog – mean value	yes	yes	yes		
Output analog – mean value	yes	yes	yes		
Minimum/maximum	yes	yes		yes ²⁾	
Impulse quantities, flow measuring					
Operational volume – absolute condition	yes	yes	yes		

Standardized volume – absolute condition	yes	yes	yes		
Error operational volume – absolute condition	yes	yes	yes		
Error standardized volume – absolute condition	yes	yes	yes		
Max. daily consumption – operational volume			Yes ¹⁾		
Max. daily consumption – standardized volume			Yes ¹⁾		
Max. hourly consumption – operational volume		Yes ¹⁾	Yes ¹⁾		
Max. hourly consumption – standardized volume		Yes ¹⁾	Yes ¹⁾		
Internal counter – absolute condition	yes	yes	yes		
Output impulses – impulse debt condition	yes	yes	yes		
Operational flow – mean value	yes	yes	yes		
Standardized flow – mean value	yes	yes	yes		
Minimum/maximum flow	yes	yes		yes ²⁾	
Conversion, ratio of compressibility factors					
Conversion factor – mean value	yes	yes	yes		
Ratio of compressibility factors – mean value	yes	yes	yes		
Minimum/maximum of conversion, of ratio of compressibility factors	yes	yes		yes ²⁾	
Binary quantities					
Binary input - condition	yes				yes
Binary output - condition	yes				yes
Set points - condition	yes				yes
Device errors and communication with converters	yes				yes
Internal binary	yes				yes
Other quantities					
Counter/timer – absolute condition	yes				
Input code					yes
Notes:					
1) Hour or day is stored along with the value (or combination, whichever suitable).					
2) Date and time or achieving the minimum/maximum is stored along with the value.					

Table 3 Options of archiving the individual quantities

7.3.1 Monthly archive

Archive capacity: 25 records

The values are saved in the archive once a month at the set “gas company“ hour (usually 6:00 am). The time data of the record is stored in the archive along with the values. If the archive is full, new data will start to overwrite the oldest ones. There is an option to store the statistical values of gas consumptions and analog quantities (see. Table 3).

The record with date 01.06 thus means statistical values of quantities in interval 1.05. 6:00 to 1.06. 6:00.

7.3.2 Daily archive

Archive capacity: 400 records

Has similar features to the monthly archive (for the list of options see Table 3); even here can be stored statistical values of gas consumptions and analog quantities. The values are stored in the archive once a day in the set “gas company” hour (usually 6 p.m.).

The record with date 13.06 thus means statistical values of quantities in interval 12.06. 6:00 to 13.06. 6:00.

7.3.3 Data archive

Archive capacity: Is variable pursuant to the configuration of the stored quantities. The capacity is operatively displayed during the configuration of the archive in the service SW.

Archiving period: Adjustable within 1 s to 1 hr

The quantities in this archive are saved in the set time period, and the period interval can be set by the user. The preset value is 1 hr. In the case of state values, the archive stores the occurrence of the active state in the pertinent archiving period. For binary inputs, the active state can be set according to the actual state of the parameterizations; log.1 is the active state for set points and errors.

7.3.4 Binary archive

Archive capacity: 2000 records

The archive stores the binary input states, state bites calculated and stored in the system, and errors of the individual devices. The values are stored in the archive only provided the state of one of the stored binaries changes. A time date with resolutions in seconds is a part of the record.

7.3.5 Limits archive

Archive capacity: 1 record for each monitored quantity

Reaching an extreme (minimum or maximum) is saved for the archived quantities. The archive saves the value and a time mark. When initiating this archive, the actual measured values of the specific quantities are set in the registers of minimums and maximums.

7.3.6 Event archive

Archive capacity: 500 records

The archive stores the date and time of the event change, state word (64 bits) describing the statuses of all the monitored events in the device and state of the counter of operational volume V1 and counters of the standardized volume Vb1. The list of monitored events in the device is in the Table 8 and Table 9.

This archive, unlike the previous archives, will not rotate after it has been filled. The archive content can not be displayed directly on the display, but it can be displayed using the service SW on a PC.

7.3.7 Settings archive

Archive capacity: An average of 500 records (depends on length/type of records)

The settings archive stores changes of parameters, especially if they have effect on metrological features of the device. The archive also stores the identification of the employee who performed the change. The record contains a time mark, employee identification, description of his/her activity, and eventually the new and old values of the parameters which were changed.

This archive, similarly as the event archive and unlike the other archives, does not rewind, i.e. after filling the archive up, one can not add to it and other changes of parameters are disabled. This archive can not be displayed on the display, and the content can only be displayed using a PC.

7.3.8 Billing archive (*)

Archive capacity: 15 records

Device contains billing archive. This archive serves as data recorder with billing period setup at device parameters. There are two possible ways how to write into this archive – one time writing according to preset time or periodically at intervals 1,2,3,4,6 or 12 months. At this time new record of all actual counters like primary volume and base volume is created including both total counter and single tariffs. Billing period is configurable and crossing time as well..

7.3.9 Gas composition archive (*)

Archive capacity: 150 records

When gas composition or compressibility calculation method are changed new record is stored into this archive. The record contains time and date stamp, previous used compressibility method and value of gas composition items. If this archive is full the oldest data records are overwritten. Notice: in old FW version changes of gas composition are recorded in setup archive.

7.4 Device parameterization

7.4.1 Parameterization using service SW

The device provides a wide range of options regarding its settings. Due to the wide range, the parameterization is performed in a full scope using the supplied service SW [22] designed for PCs. Besides the device settings, this SW also allows the read out, display, archiving, and printing of the instantaneous values as well as the archive contents. Description of the parameterization using the SW is in [19].

7.4.2 Parameterization from the device keypad

The device allows the setting of some of the selected parameters directly from the device keypad, i.e. without using a computer. These parameters are:

- Service parameters: station name, gas hour
- Communication settings: Name of station, communication protocol, transfer speed, network address, network address 2

- Gas composition (individual components of the gas pursuant to the set calculation method)
- Date and time in the device
- volume parameters like setup of gasmeter constant, V_m , V_{ms} , V_b , V_{bs} , S/N of gasmeter

Settings description is in the Art. 9.7.

7.5 Other device functions

7.5.1 Summer/winter time (DST) (*)

In device summer/winter time exchange function is implemented which can be activated (or deactivated) with service SW. If activated then device makes changes automatically based on selected region (Europe or USA). Paralelly it is necessary to setup deviation from GMT. In device archives is marked whether record was made in summer (resp. in winter) time.

7.5.2 Time synchronisation (* - only Italian version)

Device is equipped with time synchronisation function enabling time correction by authorised administrator within +/- 60s range without record into event log. If deviation is bigger than 60s upto 2 hours then time correction is allowed but record into event log is created. If deviation is bigger than 2 hours then time correction is denied and alarm signal is generated.

7.5.3 Tariff counters (*)

In device there are available four tariff counters enablig volume calculation based on default time schedule. Two independent schedules (Tariff schedule 1 and Tariff schedule 2), are changed mutually in active (resp. nonactive) mode. Single tariffs are assigned to time slots in single days and paralelly days can be defined like working days, Saturdays or Sundays (or holiday)

Each schedule has own ID number and activation time of each schedule is adjustable separately.

7.5.4 Remote download (*)

Remote download according to specification WELMEC 7.2 enables upgrade of FW remotely . For such purpose FW is equipped with unique digital signature overcoming security system at device.

7.6 Securing the device against a change of metrology parameters

The device is equipped with a metrology and service switch and uses a password system of protection against an unauthorized manipulation especially with the data which affect the metrology features of the device. Changes in device settings and other acts are stored in the settings archive. These means allow the securing of the device in compliance and even above the requirements of the EN 12405-1 standard.

7.6.1 Switch protection

There are two switches located inside the device – the metrology switch and the service switch.

7.6.1.1 Metrology switch

- protects the metrology settings of the device. It is located on the inside of the casing cover (see Fig. 3) and protected by a label which is secured by a manufacturer's security mark (official metrology mark) – see Fig. 5, Fig. 6.

7.6.1.2 Service switch

- is located next to the metrology switch (See Fig. 3). It is doubled, and when switching, it is necessary to switch both parts of the switch. Opening of the device and thus the access to this switch can be protected by a user mark, see Fig. 5, Fig. 6.

The function of the **service switch** depends on the setting of its importance in the parameters in the device. This setting is done via the service SW (menu Parameters > Meaning of service switch). Here, the user can choose what influence the switch setting will have on the individual groups of device parameters.

This variability solves the setting various options of approach to work with the device (e.g. remote parameter setting via modem...).

Service switch - meaning

The user has the option of setting one of the three meanings of the service switches in the service SW:

<i>Switch meaning</i>	<i>Position</i>	<i>Description</i>
Complete ¹⁾	OFF	Writing parameters in the device is disabled.
	ON	Parameters can be written in the device
none	OFF	The position of the switch does not matter; it is possible to write in the device. Protection using the switch is disabled.
	ON	
partial	OFF	Writing in the device is blocked, except writing the non-metrology parameters (e.g. archiving period, communication parameters, station identification, setting system time, etc.). This method of settings is convenient in the case of remote transfers of data from the device. It is suitable to secure it use using a password.

¹⁾ This meaning is preset by the manufacturer (default setting)

	ON	It is possible to write parameters in the device (i.e. the same as in case of a complete meaning).
--	----	--

Table 4 Service switch settings

7.6.2 Access passwords

The device works with two passwords: “Password for a complete access” and “Password for reading”. In the case of a blank password, the password function is turned off. It is necessary to enter a password with a max. of 6 alphanumeric characters to make the password system work. Some implemented protocols do not support using the password system during communication even if the system is turned on.

7.6.3 Access levels

Regarding the possibility of parameters modification and other operations with the device, the device users can be divided by different levels of access.

User level

- Common device user. Users of this level can read out all the data from the device and set a large amount of parameters. It is not possible to change the parameters directly influencing the metrology features of the device. For a more detailed description see Table 5. The protection by the service switch along with the user mark and password system can be used as a protection against misuse.

Accredited Service Center (ASC)

- Designed for employees of a center accredited by the manufacturer. The center is accredited to perform operations on the device regarding its metrology features. These activities are conditioned by breaking the official mark, switching the metrology switch and using a **special HW key** for the service SW [22] . For description see Table 6.

User level			
Activity		Position of the service switch	Allowing activity when using passwords
Data readout	<ul style="list-style-type: none"> - Reading the instantaneous values of quantities - Reading archives - Reading parameters 	OFF, ON	<ul style="list-style-type: none"> • Allowed when passwords turned off, • With passwords turned on allowed after entering the “password for reading”²⁾
Non-metrology changes of parameters	<ul style="list-style-type: none"> - Turning on/off archiving of the individual quantities in the individual archives - Setting the measuring period - Setting the period of archiving the data archive - Passwords changes - Zeroing the archives - Setting the internal time converter - Setting the communication parameters - Setting the station identification - Setting the hour of initiation of the gas day - Turning on/off the displaying of the instantaneous values of the non-metrology quantities on display - Configuration of digital inputs - Configuration of digital outputs - measurand marking exchange by user 	ON	<ul style="list-style-type: none"> • Allowed when passwords are turned off, • With passwords turned on allowed after entering the password for “complete access”²⁾

²⁾ The effect of the turned-on passwords can be suppressed by using the HW key WGQOI, „service“ version.

Metrological changes	<ul style="list-style-type: none"> - Assigning the influence of the service switch on entry of parameters - Setting the V and Vs counters - Change of calculation method of compressibility factor - Gas composition setting - Setting measuring units and constants - Setting default values of temperature and pressure for conversion 	ON	
-----------------------------	--	----	--

Table 5 User access level (for “complete” meaning of the service switch)

Accredited Service Center level			
Activity		Position of metrology switch	Allowing activities when
	<ul style="list-style-type: none"> - Acc activities described in the user level 	OFF, ON	<p><i>Note:</i> When using HW key, the effect of passwords is disabled provided the device uses them</p>
Metrology changes	<ul style="list-style-type: none"> - upgrade firmware - Change of the metrology approval option (NMI, ČMI, MID, etc.) - Setting a reference temperature - Setting a reference pressure - Setting the Vb, Vbs counters - Configuration of metrology quantities (C, K, V, Vb, Vs, Vbs) - Replacement of the converter - One-point or two-point addition to converter - Zeroing settings archive and status archive - measurand marking exchange by user 	ON	<p>Using HW key marked WGQOI, “Accredited service” option.</p>

Table 6 ASC access level

8 Putting in operation

Device is delivered either in operation condition with connected battery or switched out with disconnected battery.

Device is delivered in switched-out position (no displayed information after pushing of any button) and battery is placed at battery holder. There is placed blocking foil strip between battery and holder contact. Putting in operation is arranged by removing of this foil strip. This operation is also allowed at hazardous zone.



Fig. 19 Removable foil strip at battery holder

In case of disconnected battery before inserting battery into holder align up battery polarity with marked signs on holder. Only approved type of lithium battery (see technical device parameters in Chapter 12.) may be used for device feeding.

When battery is connected device is automatically putted in operation.

In basic configuration device display is switched off. Pushing of any button causes display switched on.

Note:

In case of longer holding in storage it is recommended to take out battery from battery holder or at least disconnect battery by inserting foil strip between battery and contact of battery holder.

9 Device operation

The device is not equipped with a power switch; if a supply battery is inserted in the device, the device is automatically on (the device also registers LF pulses if the battery is taken out).





A 6-button keypad serves for the operation of the device and displaying the measured and other values. The values are displayed on a graphic display with a resolution of 128 x 64 points. During battery operation, the display shuts down after 20 s from the last time you pressed any key. The display lights automatically once you press any key. In case the device is powered by an external source, the display is permanently lit.

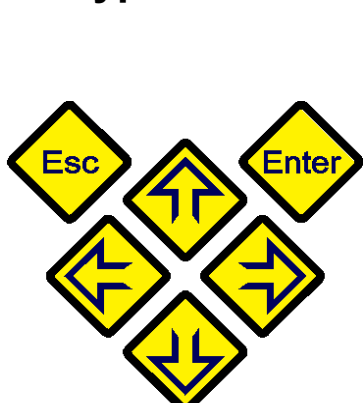

You can select the displayed data using the device menu. Displaying the menu items depends on the set parameters of the device. Content of some menu items can be custom configured.

Display features

- Automatic update of data changing with period 1 s
- Autorepeat – when holding a key, the key pressing is automatically generated, can be used for e.g. viewing archives
- Displaying without diacritical marks
- In compliance with the EN 12405-1 standard par. 6.3.1.5, the display goes in the basic display Using parameters, one can choose a time period after which the device should go back to the basic display
- To simplify the operation for an untrained user, there is an option to display gradually the instantaneous values by pressing the Enter key First, it is necessary to first get out to the highest menu level by pressing the Esc key for several times.
- To conserve energy, the device display shuts down after 20 s during battery operation; It lights up again once you press a key.

9.1 Keypad

		<ul style="list-style-type: none"> • In archive display, transition to another quantity in the set time cross-section.
		<ul style="list-style-type: none"> • In archives, transition to the previous item in the same time cross section
		Movement in time in archives, movement in a menu
		Movement in time in archives, movement in a menu

	<ul style="list-style-type: none"> • Allows transition in menu to a lower level • When displaying the instantaneous values, Enter causes scrolling through the screen for gradual display of all quantities
	<ul style="list-style-type: none"> • Transition from a submenu item to a menu of higher level

for version FW 2.XX:



	<ul style="list-style-type: none"> • Transition from the initial display to the basic information display and back • Transition from an item of the highest level of a menu to a submenu • In archive display, transition to another quantity in the set time cross-section.
	<ul style="list-style-type: none"> • Transition from a submenu item to a menu of higher level • In archives, transition to the previous item in the same time cross section

Fig. 20 Significance of keys

9.2 Menu system



The operation of the device is based on selecting from the menu. For the purpose of further explanation, we will call the basic items the main menu; by immersion in these items, we get to the lower menu levels (submenu).

If the display was off for a while, pressing any key will light on the initial display with volume values Vb and V.

Initial display



The first line displays icons in the right upper corner informing on the basic condition of the device.

Position	Meaning	Symbo l	Description
1	Communication condition		Communication via GPRS is taking place
			Communication via modem is taking place









2	Service switch condition		Service switch is in OFF position
			Service switch is in ON position
3	Battery condition		Battery is charged 100 %
			Battery is charged 50 %
			Battery is charged 25 %
4	Device condition (sum state – see art. 9.9)		Device works flawlessly
			There is an error in the device
			The device generated a warning message

Table 7 Display status icons

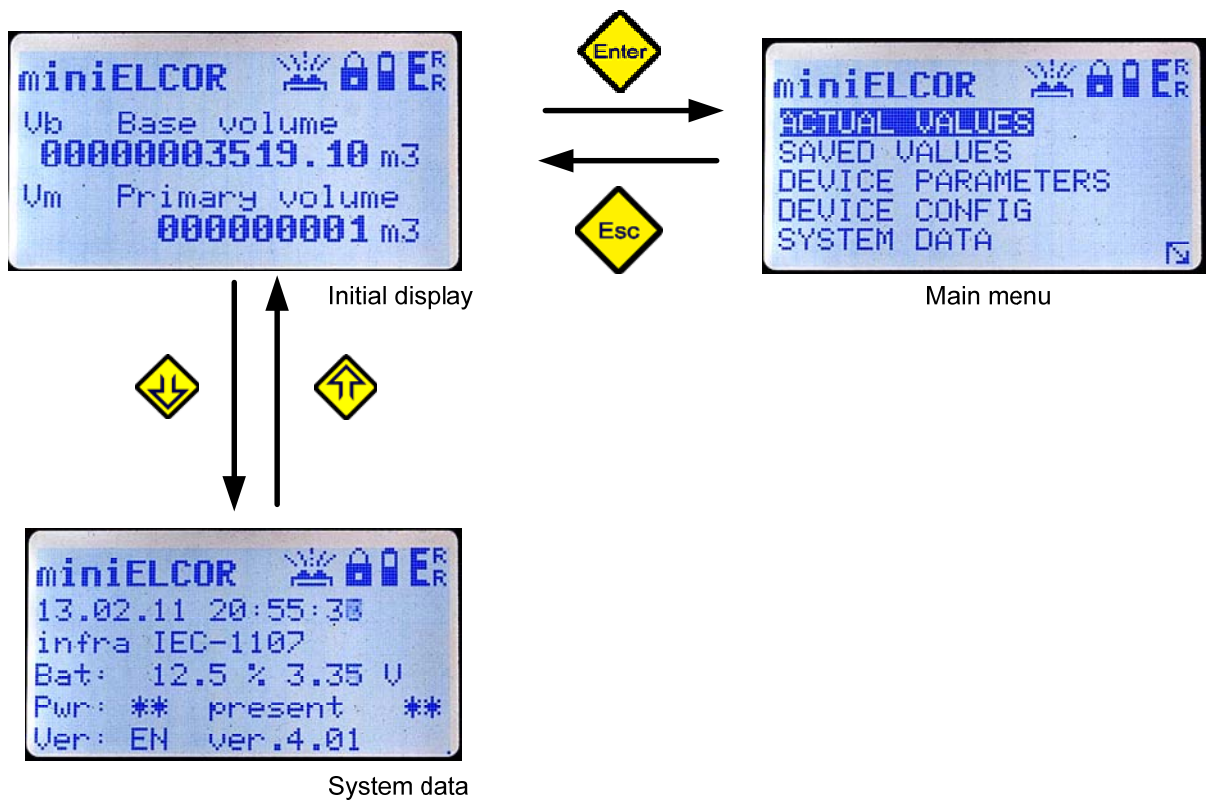

Fig. 21 Basic navigation from the initial screen (FW 4.xx)

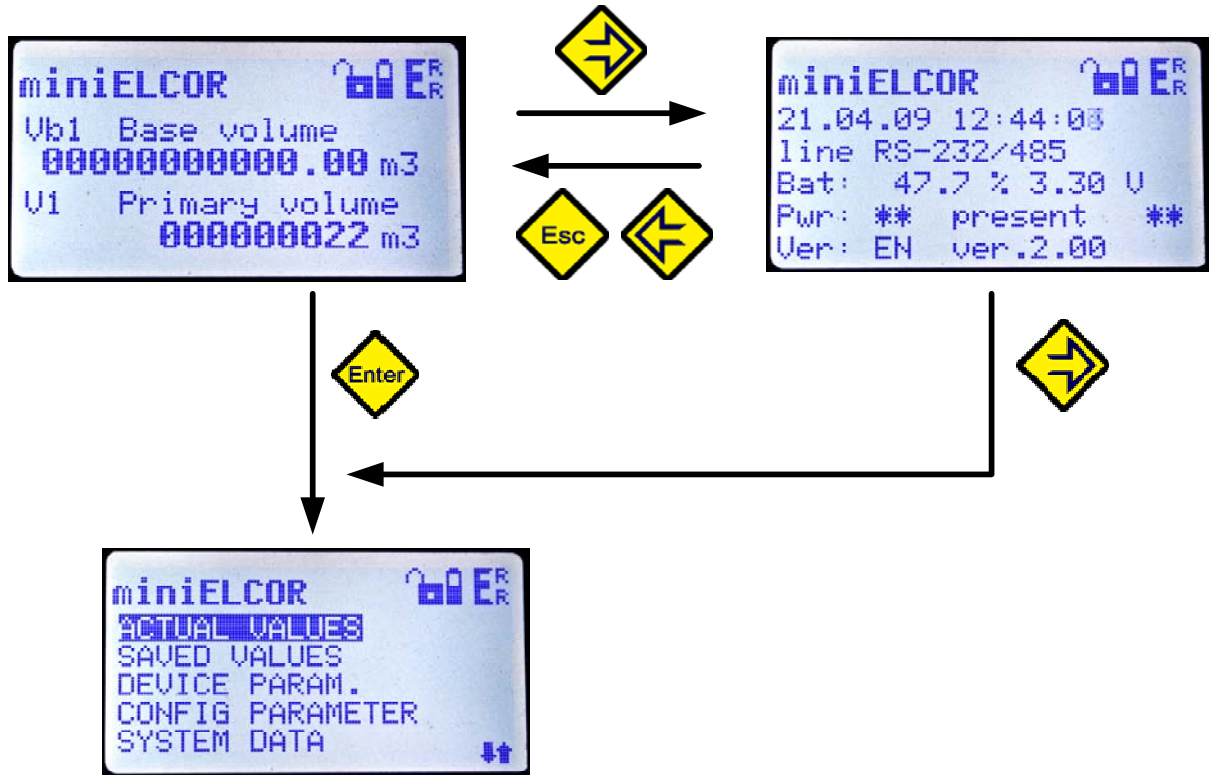
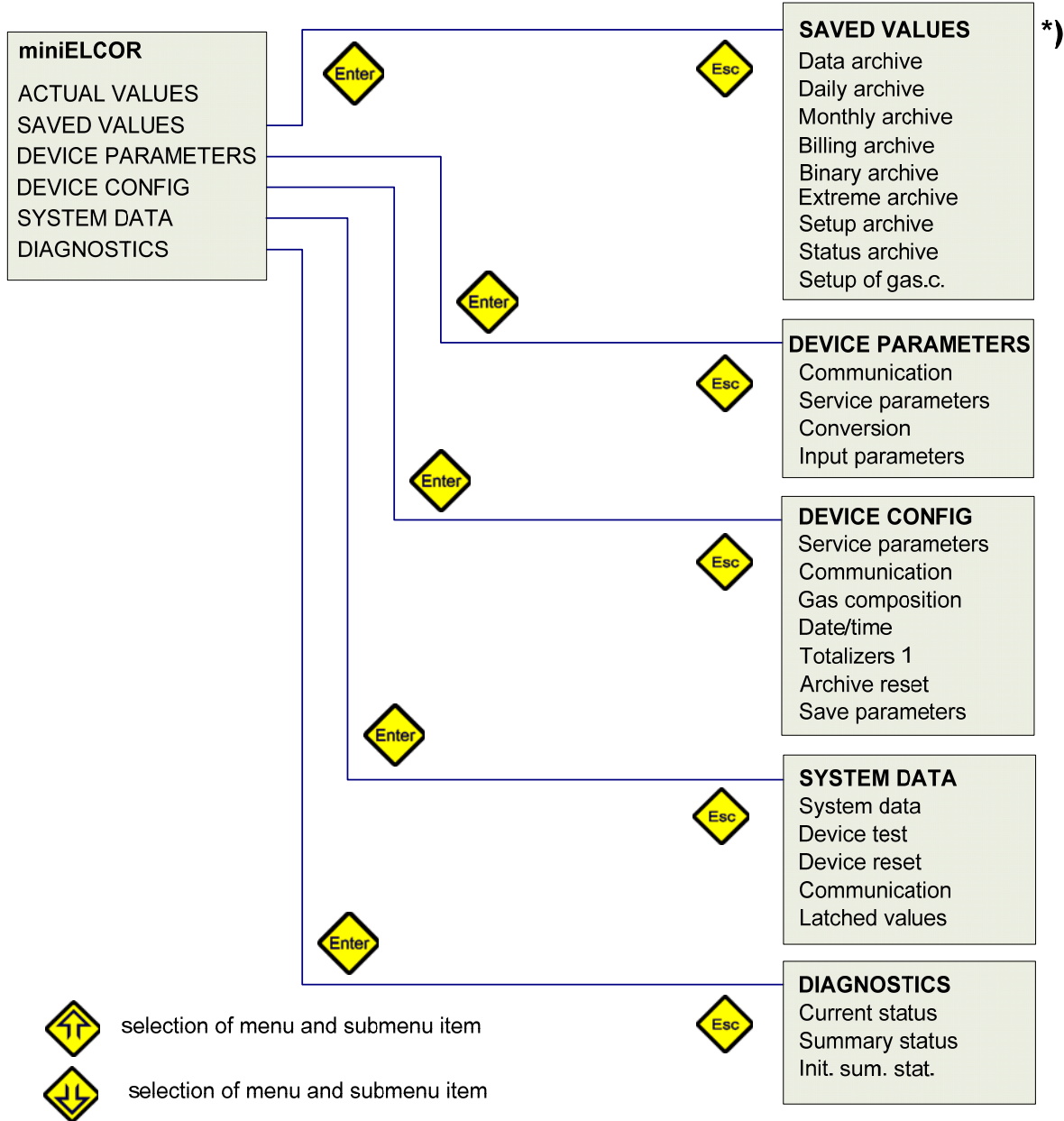

Fig. 22 Basic navigation from the initial screen (FW 2.xx)

9.3 Main menu

The selected menu item is displayed inversely on the display.

Main device menu



*) The menu items can vary from the listed ones depending on the specific device configuration. If one of the archives is missing in the menu, it means that none of the quantities in the device has archiving set up in such archive.

Fig. 23 Device main menu and first submenu level

9.4 Instantaneous values menu

After pressing the button  , the instantaneous values are displayed directly on the display. You can scroll through the data on the display using the up and down arrow buttons.

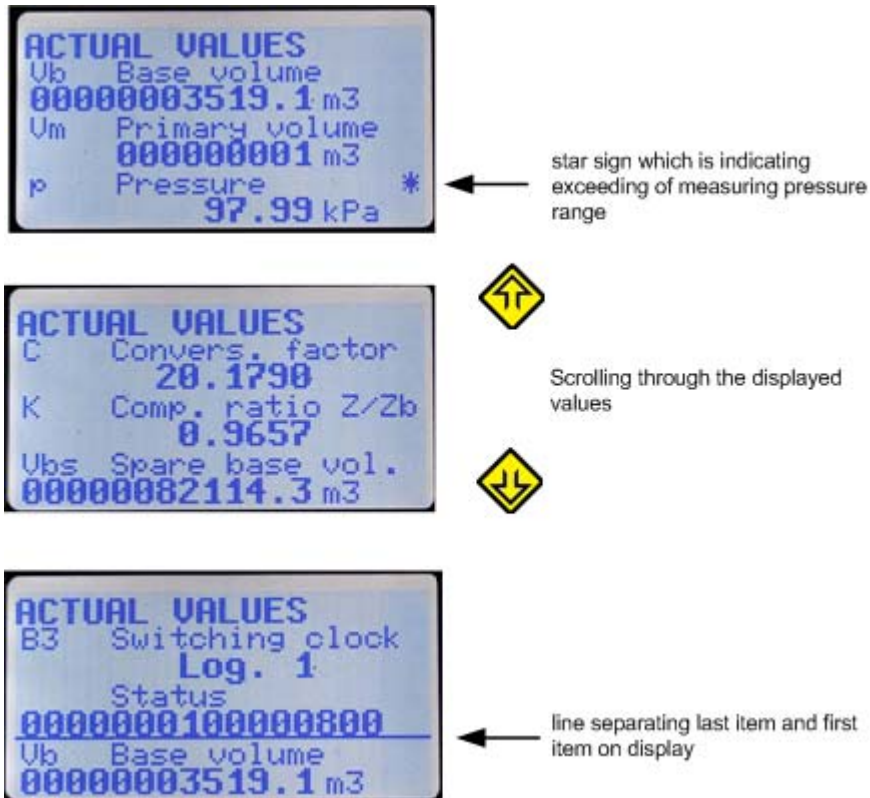

Fig. 24 Example of displaying the instantaneous values

9.5 Stored values menu

For the data, daily, monthly, and binary archives, the method of displaying the data is identical and obvious from the following picture.



Fig. 25 Navigation in archives (archiving period 15 min)

The binary archive is displayed in the same way, with the only difference that the records are not stored in the archive with an archiving period, but in times when the status of one of the stored quantities changed.

You can quit viewing the archive by pressing the key



9.6 Device parameters menu

The **Communication** menu displays the values of the following parameters:

- Transfer speed of metallic interface (RS232, RS485) [Bd]
- Transfer speed of optical interface [Bd]
- Network address
- Communication protocol

The **Service parameters** menu displays the following data:

- Device serial no.
- FW version
- Data memory
- Station name

You can scroll through the data on the display using the buttons



and



. The end of the data is marked on the display with the symbol "<".

The **Conversion** menu displays the following data:

- Conversion pursuant to a standard
- Reference pressure p_b
- Reference temperature t_b
- Compressibility Z_b
- *The individual components of the gas (display depends on the chosen conversion standard)*

The **Conversion menu – C Convers. factor** menu displays following data:

- Conversion type
- Spare temperature
- Spare pressure
- Spare compressibility
- Standard
- Pressure range
- Temperature range

The **Input parameters** menu displays the following data:

- Measuring pressure p
 - pressure range
 - serial no. of the pressure converter
- Measuring temperature t
 - measuring range
 - serial no. of the temperature sensor
- Impulse input V
 - input clamps indication
 - gas meter constant kp [imp/m³]
 - gas meter serial no.

9.7 Parameter settings menu

One can set the selected device parameters in this menu directly from the device keyboard. Setting the device parameters from the keyboard can be protected by:

- Service switch (the switch must be ON to allow writing)
- Password



A max. of 10 passwords protecting this setting, including the employee code, can be entered in the device. The password must be entered using the service SW [23]. These passwords are valid only for setting parameters from keyboard and are not related with the passwords described in 7.6.2. The password protection is turned off if an empty list of passwords is entered in the device.

The following parameters can be set:





Service parameters (*)	- Station name - Gas-day hour
Communication	- Communication protocol - Communication speed of serial interface - Communication speed of IR head - Network address - Network address 2
Gas composition	- N ₂ concentration - CO ₂ concentration - Relative density ... (the parameters depend on the selected calculation method)
Date/time	
Totalizers 1	- kp Pulse weight (Gas meter const.) [imp/m ³] - V Primary volume - Vs Spare primary volume - Gasmeter SN
Archive reset	Data archive Daily archive Monthly archive

	Billing archive Binary archive Extreme archive
Save parameters	Saving of parameters in to device

You must set the parameter you want to edit to the first line of the display using

the buttons  or  (parameter is displayed inversely). Initiate editing by pressing Enter.

The edited position in the line is marked by the symbol . Function of buttons for parameter editing:

 	Selection of the edited position in a line
 	Selection and insertion of an alphanumeric character (space, 0 to 9, A to Z, a to z)
	End of parameter editing

Saving parameters

After completion of the parameter editing, the performed edits must be written in the device. The recording in the device is performed by selecting this option. Successful recording of parameters in the device is confirmed by message “Data valid”.

Counters value and actual time are written immediately after new value setting. Before storing of new value into appropriate register there is shown confirmation message

9.8 System data menu

System data

Basic system parameters are displayed (see Fig. 21)

Device test

After selecting this menu item, the device will test its internal status and will list on the display the errors found and warning messages. The initiated test of the device takes approx. several seconds and has no effect on the measuring and archiving activities of the device.

A warning is displayed on the display during the test. The indicated errors are marked with prefix “E” and identification number; in case of a warning message the “W” prefix is used. For a complete list of errors and warning messages see par. 9.9.

Device reset

After choosing a device reset, the software jumps to the starting address and performs a repeated initialization of the entire measuring system. The contents of all archives and the statuses of all the V and Vb gas volume counters do not change during this operation. All the other set parameters also do not change.

Communication

This menu displays the set communication interface (i.e. “RS-232/485 line”, “infra IEC-1107” or communication via modem). In case of communication via GSM/GPRS mode, some diagnostic information is displayed.

Value reading

This option freezes the displayed instantaneous values. Use this option in case you need to manually copy the measured data.

9.9 Diagnostics menu

The “Diagnostics” menu stores information on the converter status.

Instantaneous status

This menu displays the instantaneous status of the device. Pressing the button “right arrow” will gradually display all the existing errors and warning messages of the converter.

Summary status

The summary status serves to monitor the occurrence of active error statuses (of the individual bit statuses of the device) from the last initialization of the summary status. That means that states of device which might have already expired are also recorded.

The basic information on the status of the summary status is also displayed in the form of an icon (see par. 9.2) on the initial device display.

Initialization of the summary status

After selecting this option using the device keypad, or using the option “Zero out the summary status” from the “Settings – Diagnostics” menu from the service PC SW, the summary status is initialized – the actual status is set according to the instantaneous status. To permit initialization procedure service switch must be in ON position. If switch is in OFF, message will be displayed that initialization procedure is denied.

9.9.1 Displaying device errors

Error messages are displayed in the “instantaneous status”, “Summary status” and “Device testing” menu. An auto diagnostic is launched regularly, a complete device test daily, a test of sensors exchange daily or irregularly when the device is turned on. The test can also be launched by choosing the “Device test” function using the keypad.

The short form of the summary diagnostics is displayed in the right corner of the highest menu level in the form of abbreviations OK, Err or Wrn (see par. 9.2). This is abbreviated for a summary of the individual statuses; the abbreviation with the highest priority is always displayed. The order of the priorities from the highest: Err, Wrn, OK. More detailed display of the diagnostic information can be done via the service SW [22].

9.9.2 Status word of the device

Status word is 64 bit. In case of change of watched bit is all word saved in Status archive. Meaning of single bits is shown in Tab. 8 and in Tab. 9.

9.9.3 Status word of the device stored in data archive

For storing into data, daily or monthly archive there is a compact status word (24 bit) defined in the device. In the archives is stored information about when given bit went during archiving interval into active state. Single bits are counted like sum of appropriate bits of Status word of the device. Meaning of single bits is shown in Tab. 10.

<i>On the display</i>	<i>Description</i>
E0 CRC program	Error of the firmware check sum.
E1 CRC loader	Error of the firmware loader check sum.
E2 CRC parameter	Error of the check sum of the device parameters.
E3 memory error	Device memory error. (FW 2.xx: E3 RAM failure)
E4	- <i>unused</i> - (FW 2.xx: E4 FLASH failure)
E5 setup full	Full settings archive.
E6 sensor change	Performed interchange of sensor or modification of its parameters.
E7 sensor commun	Error of communication with the sensor.
E8 sensor failur	Sensor error.
E9 bat. volt.low	Battery voltage dropped under the permissible level.
E10 compres.tab.	Error of compressibility table calculation due to the input parameters.
E11 compres.fail.	The compressibility calculation can not be performed due to the limitation of the range of the standard used for calculation of compressibility in the measured temperature and gas pressure.
E12	- <i>unused</i> -
E13	- <i>unused</i> -
E14 P1 min limit	Measuring range exceeded (by FW2.xx is not indicated)
E15 P1 max limit	
E16 P1 failure	
E17 T1 min limit	
E18 T1 max limit	
E19 T1 failure	
E26 synchr. RTC	Synchronisation error RTC, required shift longer than 2 hours
E27	- <i>unused</i> -
E28 encoder fault	Encoder fault

Table 8 List of events – error messages (Err indication)

On the display	Description
W0 sensor warn.	One of the connected converters has activated a warning message. More details can be found by reading out the converters parameters.
W1	- <i>unused</i> - (FW 2.xx: W1 bat.capacity low)
W2	- <i>unused</i> -
W3 overcur. term	The terminals of the internal bus have been overloaded.
W4	- <i>unused</i> -
W5 extpower fail	Outage of power supply from the network.
W6 setup archive crowded	Settings archive 80 % full. Device current overload. (FW 2.xx: W6 overcurrent dev)
W7 tamper1 fault	Tamper input 1 active
W8 tamper2 fault	Tamper input 2 active
W9 P1 min threshold	User limits exceeded (by FW2.xx is not indicated)
W10 P1 max threshold	
W11 T1 min threshold	
W12 T1 max threshold	
W13 Q1 min threshold	
W14 Q1 max threshold	
W15 Qb1 min threshold	
W16 Qb1 max threshold	
W17 C1 min threshold	
W18 C1 max threshold	
W29	- <i>unused</i> -
W30	- <i>unused</i> -

Table 9 List of events – warning messages (Wrn indication)

bit	Display	Description
0	General error	General error of device.
1	General warning	General warning of device.
2	External power supply error	Interruption of external power feeding.
3	TAMPER active	Tamper input active
4	Calculation error	Calculation error. Spare counters are used in this case.
5	Transducer error	Transducer error.
6	Value out of range	Value of pressure or temperature exceeds transducers limits.
7	Value out of range	Value of pressure or temperature exceeds limits defined by user.

Tab. 10 Compact status word of the device

10 Mounting instructions

Gas volume conversion device miniElcor is compact device inbuilt in sturdy housing made from plastic and it is corresponding with IP66 protection. Device is designed for mounting in hazardous area Zone 1 and Zone 2.

Inside the housing there is next to the completely covered evaluation electronics also placed battery and analog pressure transducer with input thread M12x1.5 according to DIN W 3861 for attachment of pressure piping.

On the bottom side of the housing there is placed 7 metal glands PG7(IP68 protection) and there are used for connecting of input and output signals with possibility of conductive connection of cable shielding.

On the front of the device there is placed foil label with display, optical interface for infrared head communication (HIE-01, 03, 04) and keypad.

10.1 Mechanical mounting of the device

The device can be easily mounted either directly to the gas meter by using single-purpose holder for given gas meter type, directly on the wall of the control station or on the gas pipeline using mounting plate.

Mounting on the wall:

The device is mounted by using 4 screws 4x30 and mounting holes which are out of the area under IP66 protection. Screws are placed in the corners on the bottom of the housing. Mounting holes for the screws are accesible after opening the housing cover.

Mounting on the pipeline:

Mechanical mounting of miniElcor on the pipeline makes easier using of mounting plate which can be mounted on the straight pipeline section via pair of mounting lugs with hold-down straps.

Lugs with the spacing corresponding to pipeline diameter will be pulled-through the holes on the mounting plate and all will be pulled on the pipe. On free ends of the lugs will be by the M6 nuts with spacers tightened hold-down straps, whereby will be mounting plate tightned on the pipeline in to the required position. Mounting plate can be installed on horizontal pipe with diameter from DN80 to DN150 or on vertical pipe with diameter from DN80 to DN200.

Fastening of miniElcor to the mounting plate is accomplished by 4 screws M4x10 ČSN 021131 via mounting holes which are accesible after opening of the housing cover. Mounting plate also makes possible to attach three way valve necessary for doing of short verification.

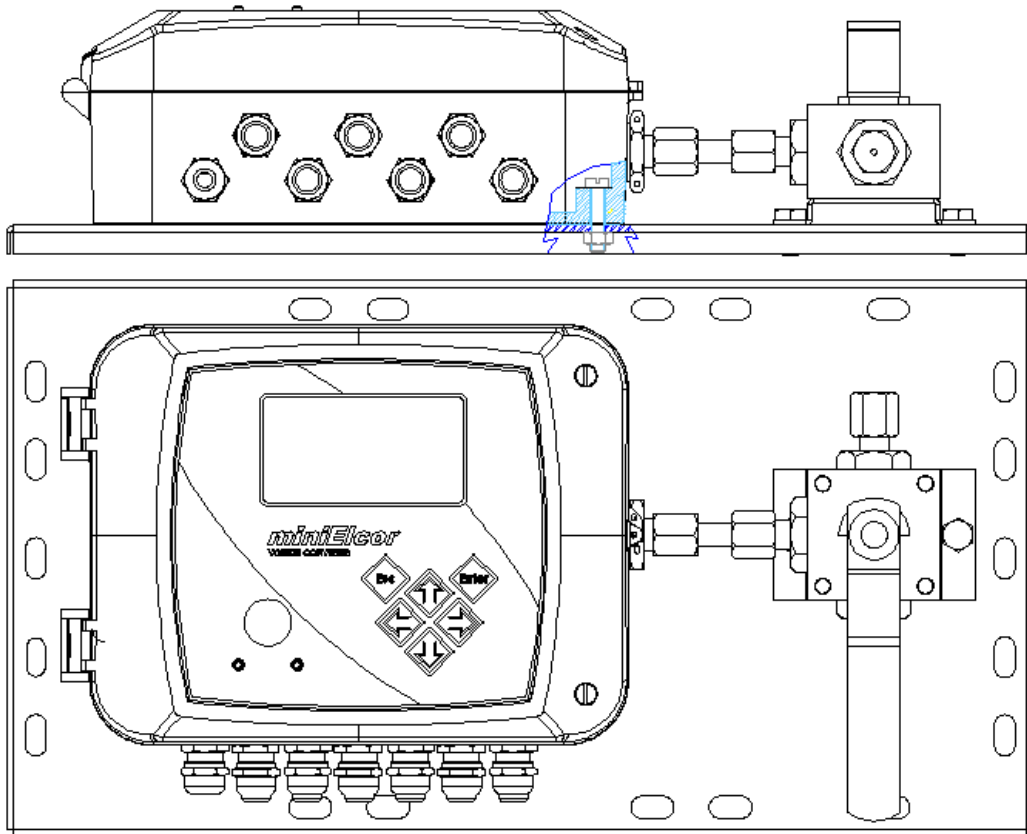

Fig. 26 Mounting of miniElcor to the mounting plate

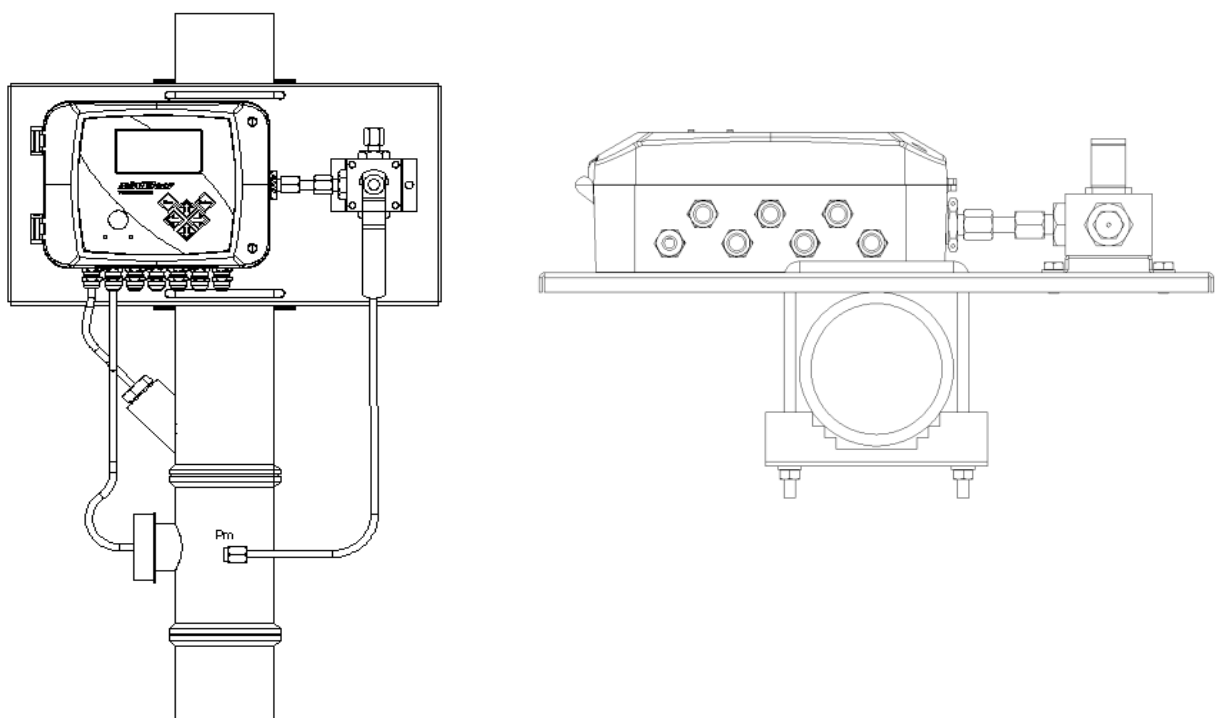

Fig. 27 Mounting on the pipeline

Pressure transducer connection

For connection of pressure input we recommend to use accurate weldless stainless steel pipe 6x1mm. For connection from the gas pipeline will be used gas meter output Pm (previous Pr) eventually it is necessary to use welded-on piece dedicated for connection of gas pipe with required size.

The case of usage connection via three way valve is shown on the Fig. 27. Stainless steel pressure pipe 6x1 of 60 mm length with prepressed ring on both sides first needs to be inserted to the endstop of pressure input of the device and tighten it by nut M12x1,5. The other end of the pipe put on „working“ output of the valve which is mounted by 4 screws M50x40 ČSN 021131 on beam of three way valve and slightly tighten the nut. In this phase tighten beam of three way valve with mounting plate by using of 2 screws M5x10 CSN 021131. Last operation is to tighten nuts on both sides of interconnecting pressure pipe.

Temperature transducer connection

For connection of temperature transducer will be priority used thermowell mounted on gas meter. If gas meter is not provided with thermowell there is a need to weld weldolet for putting thermowell according to gas meter manufacturer's instructions, in principle in distance DN – 2DN beyond the gas meter in gas flow direction. Weldolet must be welded in such way that weldolet will be during the mounting in vertical position, or diverted 45° from the vertical axis and with hollow up (Fig. 28). Thermowell with appropriate length (according to pipe inner diameter) will be screwed through the copper sealing in to the weldolet (see Tab. 10). Temperature transducer PT1000 can be now inserted in to the weldolet and tightened by safety nut.

DN (mm)	L – thermowell (mm)	weldolet
40	55	oblique
50	55	direct
80	100	oblique
100	100	direct
150	160	oblique
>200	160	direct

Tab. 10 Assigning of weldolets and thermowells according to pipeline diameter

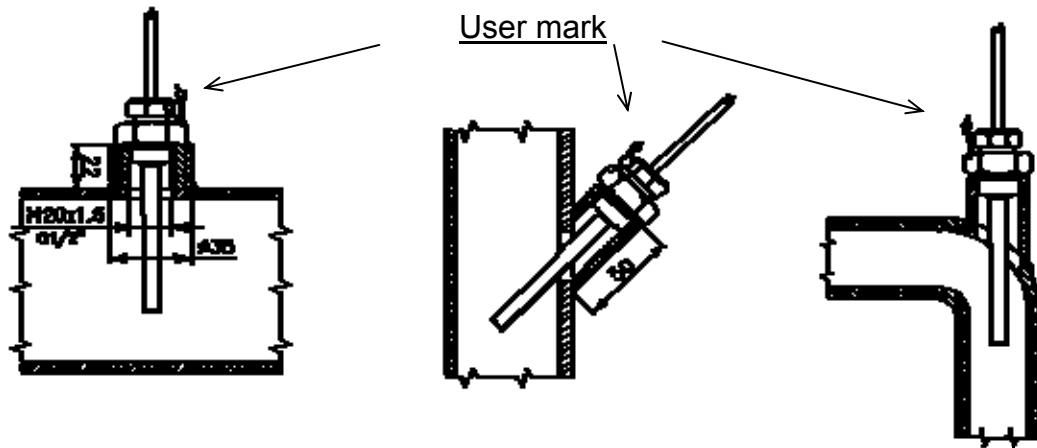

Fig. 28 Temperature sensor mounting

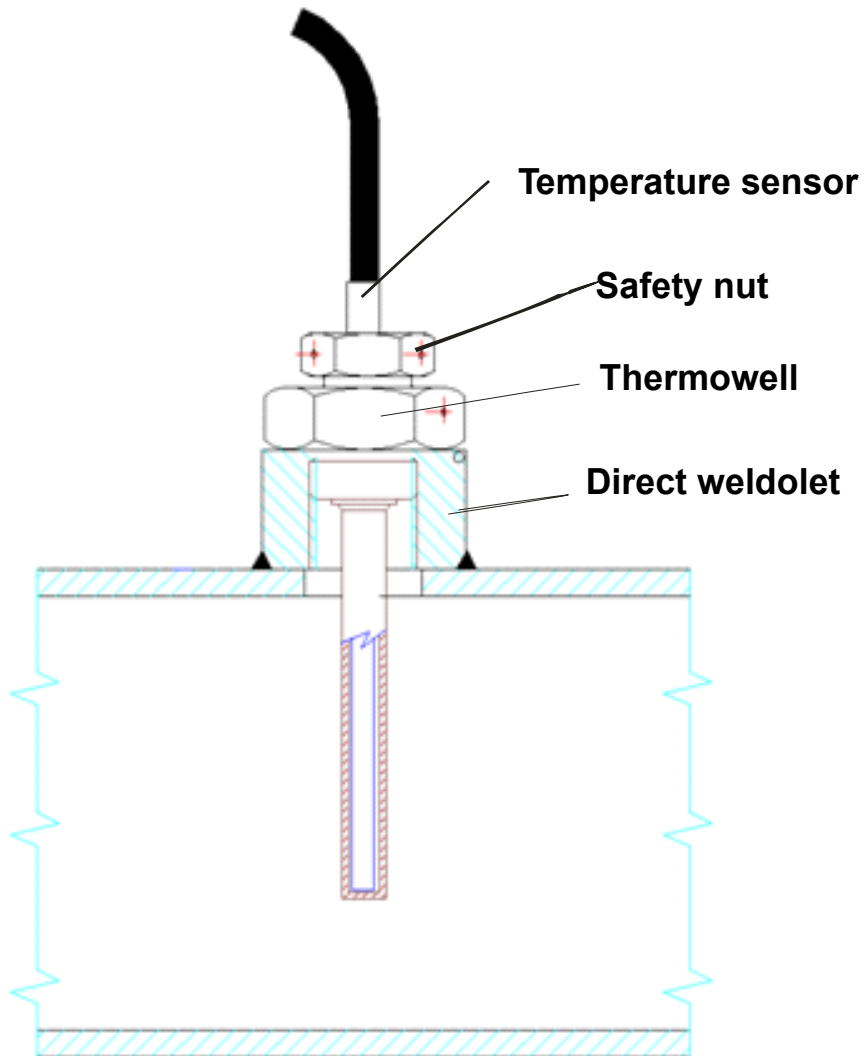

Fig. 29 Temperature sensor mounting by the help of direct weldolet

10.2 Cable connection, grounding

For interconnecting with another devices there it is necessary to use only shielded cables. On device side shielding of the cable must be attached with metal body of cable gland (according to Fig. 30). All cable glands of the device are connected reciprocally. It means that shielding of all cables coming into the device is interconnected. Thereby is ensured high resistance against electromagnetic disturbance.

Temperature sensor and external pressure transducer (if included) is also equipped with cable whose shielding is attached to metal body of cable gland. Metal part of temperature sensor is insulated. Metal body of pressure transducer is connected with cable shielding.

During installation of the device and connecting of shielding is important to avoid creating of ground loop.

Device is not necessary to ground.

For cable connection (size of conductor 0,5 – 1,5 mm²) there are used clamps mounted in the device, in whose nearness there is printed on the board description of signal which is assigned to each clamp (see Fig. 12). Before connecting cables it is necessary first to apply wire-end ferrule on the stripped end of the wire and force on them by pliers which are supplied by the manufacturer of wire-end ferrules. Wires ended by ferrules it is possible to plug in to the clamps without need of special tool. During wire disconnecting it is necessary to slightly push nose of the clamp and carefully take out the wire.

	cable type	cable diameter	Recommended cable type
Pulse input	Shielded 2 wire cable	4 – 6,5 mm	Unitronic LiYCY 2 x 0.25 Lappkabel Stuttgart SRO 2.22 ČSN347761 Kablo Velké Meziříčí
External power feeding	Shielded 2 wire cable	4 – 6,5 mm	Unitronic LiYCY 2 x 0.75 Lappkabel Stuttgart
Pulse outputs	Shielded 6 wire cable	4 – 6,5 mm	Unitronic LiYCY 6 x 0.25 Lappkabel Stuttgart SRO 6.22 ČSN347761 Kablo Velké Meziříčí
RS-232 connection	Shielded 4 wire cable	4 – 6,5 mm	Unitronic LiYCY 4 x 0.25 Lappkabel Stuttgart
RS-485 connection	Shielded 4 wire cable	4 – 6,5 mm	Unitronic LiYCY 4 x 0.34 Lappkabel Stuttgart

Tab. 11 Recommended cable types

Temperature resistance of SRO cable type is given by manufacturer in range -5°C - +45°C. Manufacturer Lappkabel Stuttgart is guarantee resistance on their product Unitronik LiYCY for moving lead-wires in range -5°C - +70°C and for immovable lead-wires in range -30°C - +80°C. From these values ensue also temperature conditions for mounting of the device.

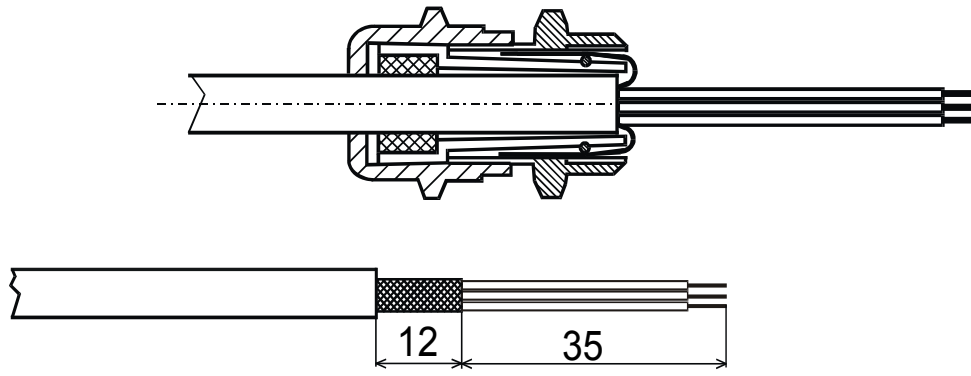

Fig. 30 Shielding connection in bushing

11 Accessories

11.1 Assembly accessories

- 1 pc assembly board (metal)
- 2 pcs stirrup with splice
for assembly of board on pipes (for pipes Ø 50 mm, Ø 100 mm, Ø 150 mm – must be specified when ordered)
- 1 pc temperature well (length 54 mm, 100 mm, 160 mm – must be specified when ordered)
- 1 pc of welded-on piece for the temperature well (direct or slant – must be specified when ordered)
- 1 pc three-way tap PN 100

11.2 Intrinsically safe supply sources for external power supply

- JBZ-01 (power supply from 230 Vac)
- JBZ-02 (power supply from 12 Vdc)

11.3 Separation and communication modules

- DATCOM-S1, DATCOM-S2
- DATCOM-K1, DATCOM-K2
- DATCOM-K3, DATCOM-K4

11.4 GPRS communicators

- DATCOM-AMR1 (battery supply of the communicator)
- DATCOM-AMR2 (battery supply of the communicator)
- DATCOM-AMR3/S (accumulator power supply of the communicator with solar charging)
- DATCOM-AMR3/E (accumulator power supply of the communicator with charging from network 230 Vac)

11.5 Other accessories

- CL -1 4-20 mA analog output module
- HIE-03 Infra-red head with RS232 communication interface
- HIE-04 Infra-red head with USB communication interface
- EDT 23 Digital pressure transmitter, type of protection "i" - intrinsically safe
- EDT 34 Digital temperature transmitter, type of protection "i" - intrinsically safe
- module RS-485 expansion module KP 065 08 for digital transmitter connection (board with cover)

12 Technical parameters

Mechanical parameters

- mechanical dimensions (w x h x d)	...	193 x 160 x 73
- weight	...	1.2 kg
- casing material	...	polycarbonate
- terminals – conductor cross section	...	0.5 mm ² – 1.5 mm ²
- mechanical class	...	M2
- electromagnetic environment	...	E2

Environment

- protection	...	IP66, pursuant to EN 60529
- working temperature	...	-25 °C - +70 °C
		Readability of display in ambient temperature below -20 °C is not guaranteed.
- storing temperature	...	-40 °C - +85 °C
- working position	...	vertical ³⁾
- humidity	...	max. 95%, non-concentrating vapors
- protection against dangerous touch of live and non-live parts	...	Small voltage

Non-explosive design – *intrinsically safety*

- indication, miniELCOR	...	⊕ II 1G Ex ia IIC T4/T3 - ZONE 0
miniELCOR SCR	...	⊕ II 2G Ex ib IIB T4/T3 - ZONE 1
- certificate no.	...	FTZÚ 08 ATEX 0324X
- environment classification (Zone)	...	see above (indication)

Power supply

- supply battery type	...	Lithium 3.6V/17Ah (size D)
- supply battery life time	...	6 years ⁴⁾
- supply battery voltage	...	2.8 ÷ 3.6 V
- measuring the supply battery life time	...	Yes, alert 90 days before discharge
- back-up battery type	...	Lithium 3.6V/1Ah (size ½ AA)
- back-up battery life time	...	10 years

Power supply from external source

		PWR (GND,+) terminals
- External JB source type	...	JBZ-02 (JBZ-01, DATCOM-Kx)
- supply voltage of the external JB source	...	4.5 – 10V (inputs type NAMUR not used)
U_{PWR}	...	7 – 10V (inputs type NAMUR used)
		Note: real value depends on type of connected sensor NAMUR
- cable length	...	30 m

Device accuracy, metrology parameters

- measuring principle	...	PTZ converter, 1 channel ⁵⁾
-----------------------	-----	--

³⁾ Recommended working position. In case of a working environment where humidity condensation avoidance is ensured, the device can also be installed in horizontal position.

⁴⁾ The life time of the supply battery depends on the set mode, and the life time of the back-up battery depends on the method of using the device without the charging battery

⁵⁾ Even simpler options of conversion can be configured. Supported options are PTZ, PT, TZ and T.

- type approval mark ... TCM 143/06 – 4664
(in accordance certification under MID)

Relative error (within scope of working temperatures)

- max. total error of the converter ... < 0,5 % of the measured value
< 0,3 % of the range ⁶⁾
... (version without MID certification)
- typical total error of the converter ... 0.15 % of the measured value
0.10 % of the range ⁷⁾
... (version without MID certification))
- Operational volume measuring error ... No error
- Compressibility factor calculation error ... < 0,05 %
- Compressibility factor calculation ... AGA-8 92DC, AGA NX-19 mod, AGA 8-G1,
AGA 8-G2, SGERG-88, constant ⁷⁾

Measuring pressure

- Number of inputs ... 1
- Sensor ... Silicon piezoresistant sensor
- **certification under MID**
 - measuring ranges ... 80 ÷ 520 kPa
... 200 ÷ 1000 kPa
... 400 ÷ 2000 kPa
... 700 ÷ 3500 kPa
... 1400 ÷ 7000 kPa

... 80 ÷ 1000 kPa ⁸⁾
... 400 ÷ 7000 kPa ⁹⁾
 - measuring error ... < 0.25 % of the measured value
 - long-term stability ... < 0.1 % for each year of the measured value
... < 0.2 % for each year of the range
- **without MID certification**
 - measuring ranges ... 80 ÷ 520 kPa
... 80 ÷ 1000 kPa
... 80 ÷ 2000 kPa
... 80 ÷ 3500 kPa
... 80 ÷ 7000 kPa
 - measuring error ... < 0.20 % of the range ⁷⁾
 - long-term stability ... < 0.2 % for each year of the range ⁷⁾
- maximum overload rating ... 125 % of the upper limit of the measuring
range
- mechanical resistance ... 10 MPa⁹⁾

⁶⁾ In case of device version without MID certification there is a measurement error specified in percentage from the range according to american usage.

⁷⁾ Selected calculation method of compressibility can involve temperature range. See Table 1.

⁸⁾ Enhanced range for extra charge. Can not be combined with enhanced accuracy.

- Connecting pressure	... tube \varnothing 6 mm, screwing ERMETO M12 x 1.5
- design	... Internal ... External, standard cable length 2.5 m max. 5 m
Measuring temperature	
- Number of inputs	... 1
- Sensor	... Pt 1000, platinum resistor detector
- measuring range	... $-25 \div +60$ °C
- measuring error	... ± 0.2 °C
- long-term stability	... < 0.02 % for year (relative error in K)
- sensor design	... tube \varnothing 5.7 mm, length 120 mm with integrated cable
- length of external sensor cable	... Standard 2.5 m, max. 10 m
Internal temperature measuring	
- measuring error	... ± 3 °C
Real time circuit	
- long-term stability	... ± 5 min / year at 25 °C
Digital inputs	
	INPUTS terminals
- number	... 4
- input options	... LF impulse input, HF impulse input NAMUR, binary input low-input, binary input NAMUR
- length of cable for the individual inputs	... 30 m
Binary input - classic	
	... Terminals DI1(LF+/-), DI2(LF+/-), DI3, DI4
- Max. number of inputs	... 4
- input type	... Low-input input – connecting reed contact or no-potential output
- min. time of status duration	... 100 ms
- open circuit voltage	... 2.5 V - 3.6 V
- Shortage current	... Approx. 3 μ A
- level "ON"	... $R < 100$ k Ω or $U < 0.2$ V
- level "OFF"	... $R > 2$ M Ω or $U > 2.5$ V
LF impulse input	
	... Terminals DI1(LF+/-), DI2(LF+/-), DI3, DI4
- Max. number of inputs	... 4
- max. frequency	... 10 Hz
- input type	... Connecting reed contact or no-potential output, WIEGAND
- min. length of pulse / pause	... 40 ms
- open circuit voltage	... 2.5 V - 3.6 V
- Shortage current	... Approx. 3 μ A
- level "ON"	... $R < 100$ k Ω or $U < 0.2$ V
- level "OFF"	... $R > 2$ M Ω or $U > 2.5$ V

⁹⁾ Will damage pressure converter, the gas-tightness remains the same.

Binary input - NAMUR ¹⁰⁾	... Terminals DI1 (HF+/-), DI2 (HF+/-)
- Max. number of inputs	... 2
- input type	... NAMUR (DIN 19234)
- min. length of pulse / pause	... 200 ms
- open circuit voltage	... U_{PWR}
- Internal resistance	... 1 k Ω
HF impulse input – NAMUR ¹¹⁾	... Terminals DI1 (HF+/-), DI2 (HF+/-)
- Max. number of inputs	... 2
- max. frequency	... 5 kHz
- input type	... NAMUR (DIN 19234)
- min. length of pulse / pause	... 100 μ s
- open circuit voltage	... U_{PWR}
- Internal resistance	... 1 k Ω
Input ENCODER – NAMUR	Terminals DI1 (HF+/-)
- Max. number of inputs	... 1
- type	... NAMUR (DIN 19234)
- type of input	... Absolute ENCODER S1
Input ENCODER – SCR ¹²⁾	Terminals SCR (A,B)
- type	... SCR+
- supported communication protocol	... OBIS 2005 (IEC 62056-21 Mode A) (under preparation EDIS (IEC1107 Mode A))
- power supplied voltage for encoder	... 5 V
- cable length	... 30 m
Digital outputs	... OUTPUTS terminals
- number	... 4
- outputs options (sw configuration)	... Impulse output, binary output, analog output (via CL-1)
- Output types	... Open collector
- length of cable for the individual outputs	... 30 m
- without galvanic separation	
Binary output	DO1, DO2, DO3, DO4 terminals
- Max. number of outputs	... 4
- max. voltage	... 15 V
- max. current	... 100 mA
- max. resistance in connected status	... 10 Ω
Impulse output	... DO1, DO2, DO3, DO4 terminals
- Max. number of outputs	... 4
- max. voltage	... 15 V
- max. current	... 100 mA
- max. resistance in connected status	... 10 Ω
- time of connection	... Programmable 0.1 s – 25 s (step 0.1 s)
- time of disconnection	... Programmable 0.1 s – 25 s (step 0.1 s)

¹⁰⁾ The device must be charged from an external source JBZ-02.

¹¹⁾ The device must be charged from an external source JBZ-02.

¹²⁾ [Optional accessories – influences gas group and category of intrinsically safety](#)

Analog output	DO1, DO2, DO3, DO4 *) terminals
- Max. number of outputs	... 4
- Output type	... Current output 4-20 mA (realized by moduls CL-1)

**Connection of external transducer via expanding module RS-485 – optional
(communication line RS-485 internal bus)**

- Expanding module marking	... KP 065 08
- Communication interface for transducer	... RS-485 (intrinsically safe)
- communication protocol	... MODBUS RTU
- max.number of connected modules	... 1
- max. length of cable of transducer	... 100 m
- recommended type of pressure transducer	... EDT 23 (intrinsically safe)
- recommended type of temp. transducer do	... EDT 34 (intrinsically safe)

Interface for communication with superior system ... All three interfaces share the same communication channel – can not be operated simultaneously

Metallic interfaces

- galvanic separation	yes
- Interface of serial communication	RS-485 or RS-232 (not possible simultaneously)
- Communication protocol	... Optional, according to the firmware version
- Communication speed	... 9600 Bd – 57600 Bd, adjustable
- Byte format	... 8 bits, 1 stop, without parity

RS-232 line

- connection via JB separator	... RS232 terminals (GND1, CTS, TxD, RxD), E.g. MTL5051
- cable length	... 30 m

RS-485 line

- connection via JB separator	... RS485 terminals (GND1, U1+, D1+, D1-)
- max. cable length	... Datcom-K3, Datcom-K4
	... <100 m

IEC-1107 interface

- Communication speed	... 9600 Bd to 38400 Bd
-----------------------	-------------------------

Possible inputs / outputs configurations

	Binary input		Impulse input	
	Classic	NAMUR	LF	HF (NAMUR)
DI1	YES	YES	YES	YES
DI2	YES	YES	YES	YES
DI3	YES	-	YES	-
DI4	YES	-	YES	-

	Binary output	Impulse output	Data output*)
DO1	YES	YES	YES
DO2	YES	YES	YES
DO3	YES	YES	YES
DO4	YES	YES	YES

*) necessary to connect an external module CL-1 using the JB separator (e.g. Datcom-K3)

13 Inexplosiveness parameters

HF inputs NAMUR DI1, DI2: *HF+, HF- (INPUTS) Terminals*

$$U_o = 10V$$

$$I_o = 11mA$$

$$P_o = 27mW$$

	IIC	IIB
Co	2,8 μ F	18 μ F
Lo	200mH	700mH

LF inputs and binary inputs DI1, DI2, DI3, and DI4: *LF+/-, DI3+/-, DI4+/- (INPUTS) terminals*

$$U_o = 6.5V$$

$$I_o = 8mA$$

$$P_o = 15mW$$

	IIC	IIB
Co	2,8 μ F	18 μ F
Lo	200mH	700mH

RS485 communication line – internal bus (optional): *Terminals GND, U+, D-, D+*

$$U_o = 6.5V$$

$$I_o = 1A$$

$$P_o = 1.1W$$

	IIC	IIB
Σ Co	3,5 μ F	250 μ F
Σ Lo	30 μ H	120 μ H

Digital outputs DO1 to DO4: *Terminals GND, DO1, DO2, DO3, DO4 (OUTPUTS)*

$$U_i = 15V$$

$$\Sigma P_i = 1W$$

$$C_i = 500nF$$

$$L_i = 0$$

External power supply: *PWR (GND,+) terminals*

$$U_i = 10V$$

$$I_i = 0.2A$$

$$P_i = 0.33W \text{ (} P_i = 0.41W \text{ only for JBZ-02, JBZ-01)}$$

$$C_i = 0$$

$$L_i = 0$$

RS485 communication line – communication with superior system: *Terminals GND1, U1+, D1-, D1+*

$$U_i = 10V$$

$$\Sigma P_i = 0.33W^* \text{ (sum of outputs in RS485 and RS232)}$$

$$C_i = 2.8\mu F$$

Li = 0

RS232 communication line – communication with superior system: *Terminals*
GND1, CTS, TXD, RXD

Ui = 20V

$\Sigma P_i = 0.33W^*$ (sum of outputs in RS485 and RS232)

Ci = 200nF

Li = 0

or

MTL5051 (only terminals 1,2,5,6)

* Note: Sum of outputs is defined jointly for both interfaces, i.e. sum of outputs on RS485 and RS232 must not exceed 0.33W except MTL5051.

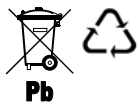

The battery used in the device belongs in the hazardous waste category. The used batteries can be returned to the manufacturer.

14 Device setting

After assembly and connection of the device in the measuring place is necessary to set several device parameters (gas meter serial number, gas meter constant and station identification, etc.). Setting of the device is made with help of service SW. The installation is made with starting up of the file SETUP.EXE

For parameters setting is necessary to have the service switch in position "On".

14.1 Standard device control after installation

Recommended setting and control progress are necessary for correct device function:

- control of system time in the device (see paragraph 14.3.3)
- control of computing algorithm and gas composition setting (see Fig. 32)
- gas meter constants and gas meter serial numbers setting (see paragraph 15.2)
- setting of default pressure and temperature values (see paragraph 14.3.5)
- actual values of counters reconciliation with gas meter volume (see paragraph 14.3.6)
- control of device diagnostics, removal of possible problems, initialization of device summary status (see paragraph 14.3.7)
- clear of device archives (see paragraph 14.3.8)

It is necessary to adjust this progress for other functions and controls (output settings, external power supply, etc.) during concrete installation. Archives clearing and summary status clearing must be completed at the end of control. After ending of device setting is necessary to switch the service switch in „**Off**“ position.

Notes:

1. Metrological device parameters are set from the manufacture so that the device will work according to customer's requirements. Metrological values setting are protected by HW key and metrological switch. This switch is secure with authorized mark.
2. The possibility to set other device parameters is protected with service switch, perchance with the password.
3. The device is delivered without active passwords.

Values of these parameters can be displayed on the device display by choice in device menu – *DEVICE PARAM.* -> *Communication.*

14.2 Device connection with PC

The device can be connected with PC either with help of cable by force of serial interface RS-232 (eventually RS-485), infrared-head (HIE-01) or eventually via modem.

For device setting in terrain is best to use infrared-head or cable RS-232 (see Fig. 18). In case of communication through infrared-head is to this communication assigns the highest priority and the device will automatically choose this communication.

Warning:

If is the PC used in the explosive surround (ZONE 1 or ZONE 2), then must be during connection between device and PC accomplished all protecting norms.

Communication parameters (default setup)

In the device are pre-set from the manufacture these parameters for connection with PC (or modem):

Communication speed, interface RS232/RS485	38 400 Bd
Communication speed, optical interface of infra red head	9 600 Bd
Communication protocol	ELGAS (ver. 2)
Communication address of device (see further)	Address1=0 Address2=0

14.3 Setting of communication between device and PC

When is device connected with PC, then it is possible to start-up service SW with double-click on its „exe file“. After SW starting are displayed already defined devices (consumption places) see Fig. 31. In this list is for one device determines one line. In each line are defined all parameter for device identification and for communication line assignment. User may edit parameters very easily with double-click on each window. By some parameters symbol of arrow is displayed in right corner. Clicking on this arrow user can choose from several possibilities. When user cannot find the device in the list or the list is empty so it is necessary to make a new line with definition of new device (consumption place). The new line is made out after click on icon „+“. Parameter setting of new consumption place is the same like editing of existing consumption place.

14.3.1 Parameters setting of consumption place

By all consumption places are in columns arrange identifying data and data which are necessary for communication.

- **Station description** – users marking of station
- **Station identification** – station marking; this marking (name of the consumption place) must be the same with marking, which will be written in the device memory

- **Tel. no.** – fill up only, when is the communication via modems. Fill up telephone number of modem, which is connected with device.
- **IP address:port** – fill up only in case of LAN network or GPRS connection (data is possible to receive from administrator)
- **UDP** - choose **No**.
- **Name of comm. channel** – after double-click choose communication channel (description – see paragraph 14.3.2)
- **Addr.1, Addr.2** – if you have only one connected device fill up zeros – in case of placing in communication network must be filled up its actual address
- **Protocol** – Choose the same which is set in the device. For establishing of first communication is in the device set communication protocol ELGAS (ver.2)

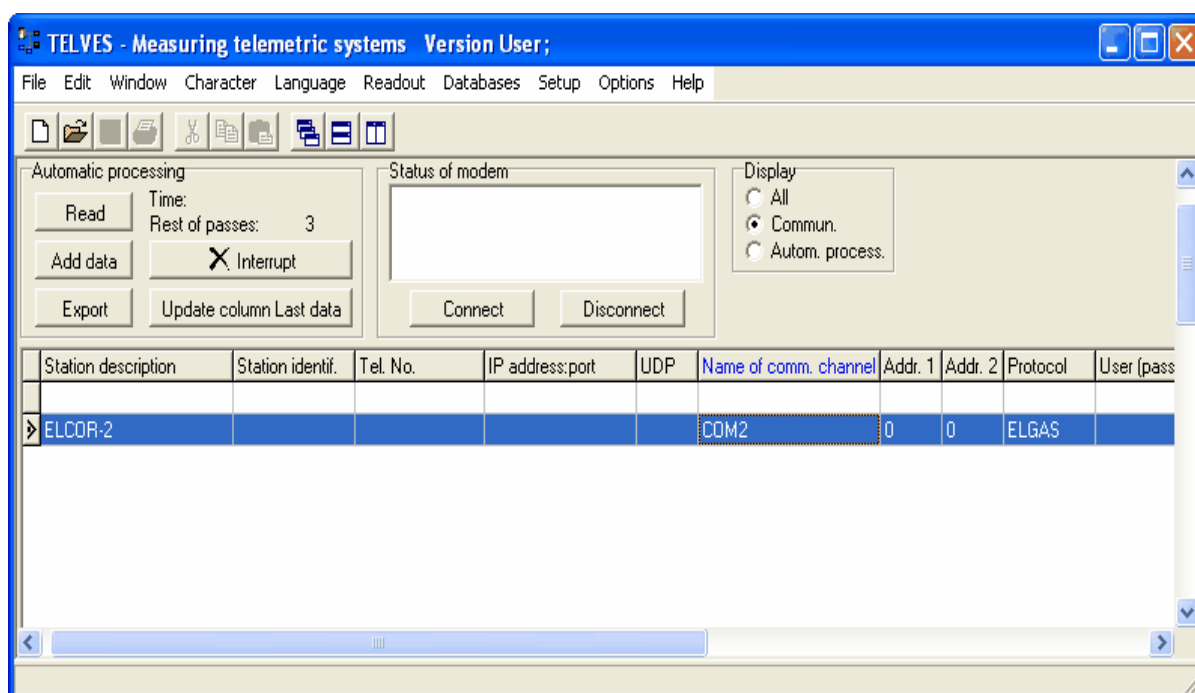

Fig. 31 Consumption place setting

Note for parameters Addr.1, Addr.2:

Parameters Addr.1, Addr.2 address device connected which is connected to communication device in given consumption place. In case that this consumption place includes more connected devices then is necessary to differentiate devices with help of these addresses. For connecting of communication device (PC) with conversion device must be in these parameters given the address, which is set in connected device (see 14.3.5). In case, that there is connected only one device so is possible to leave these parameters with zero, because in so case the device answer even if it has arbitrary address.

WARNING (is valid for MODBUS protocol):

In case of using **MODBUS** protocol (see 15.7) is used only address Addr.1. In this case you cannot use zero address; you have to use non-zero address Addr.1 which is set in the device (in range from 1 to 247) or you may use universal address **Addr.1 = 248**. The device will answer on this address always.

If all data in the line is set in the right way, then the consumption place is set and the communication way between PC and device is ready. The user may test communication with the help of actual values reading (menu choice **Readout -> Actual values**).

14.3.2 Communication channel setting

For successful communication between device and PC must be correctly set the communication channel. For communication channel setting must be chosen correct communication interface, communication speed, etc.

Setting progress

- From menu choose: **Options -> Communication channels**
- In case of adding a new device in to the set service SW is possible to choose already defined communication channel or define a new communication channel with the button „+“ see Fig. 32.
- Setting of new communication channel starts with choosing of connection between device and PC (programme switch **Communication medium**). For communication via infrared-head choose **RS-232** and relevant communication port **COM**. After this selection will be the new communication channel added in the table **Configuration of communication channels**.

Configuration of communication channel:

- name of communication channel – here assign your own mark (in case of more communication channels is it better for its identification)
- Speed of communication channel:
 - communication via infrared-head HIE-03,04 – communication speed up to 38 400 Bd (older model HIE-01 - communication speed 9600 Bd)
 - communication via serial port – Communication speed up to 38 400 Bd.
 - communication via modem – communication speed is set according to communication speed of modem.
- Other parameters are without changes.

Basically if user wants to edit the table, change is made with click on item.

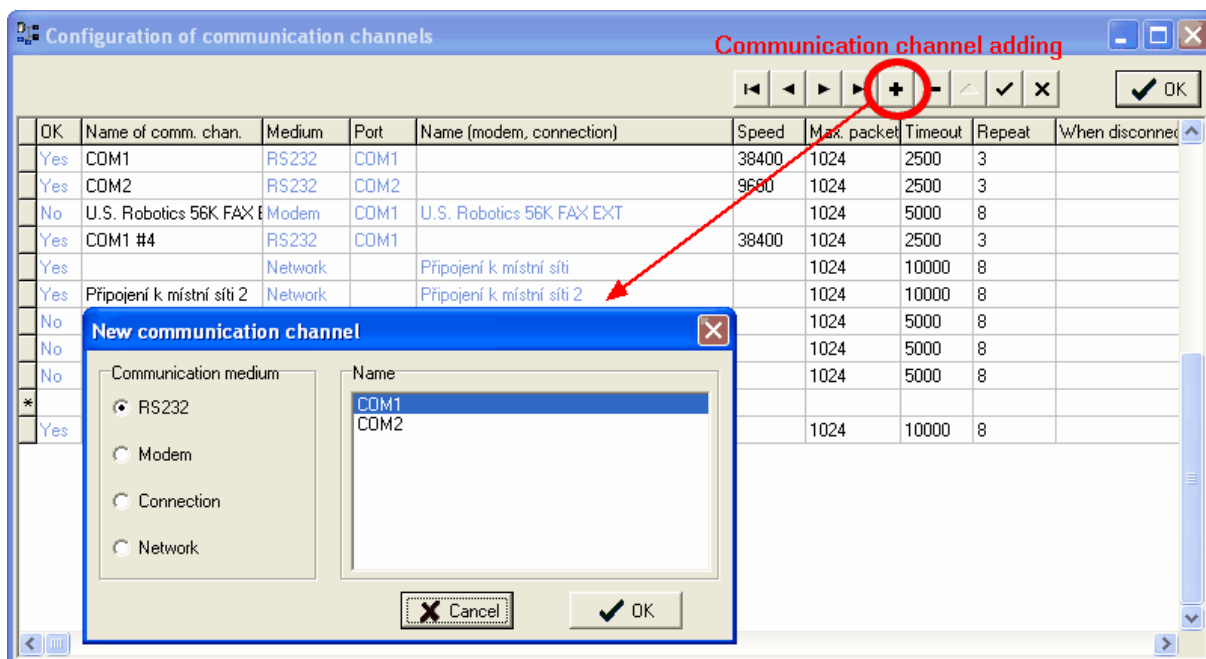

Fig. 32 Adding of new communication channel

After complete definition of new communication channel is a new setting saved with pressing the button **OK**. New defined channel may be chosen by setting of consumption places setting (see paragraph 14.3.1).

14.3.3 Control and setting of system time

In the device are real time clock with calendar. It is possible to display actual date and time on device display in menu **System data** or with reading out of actual values with help of service SW. The item **Setup -> Date and time** in programme menu allows changing these values.

14.3.4 Readout and setting of parameters in the device

The user may readout parameters from the device with help of item from menu **Readout -> Parameters**.

After parameters readout are data from the device displayed in single window. The use may with help of icon  choose between two types of display mode:

a) Simple mode display

On the screen are displayed base device parameters with possibility of their setting (see Fig. 33 and Fig. 34).

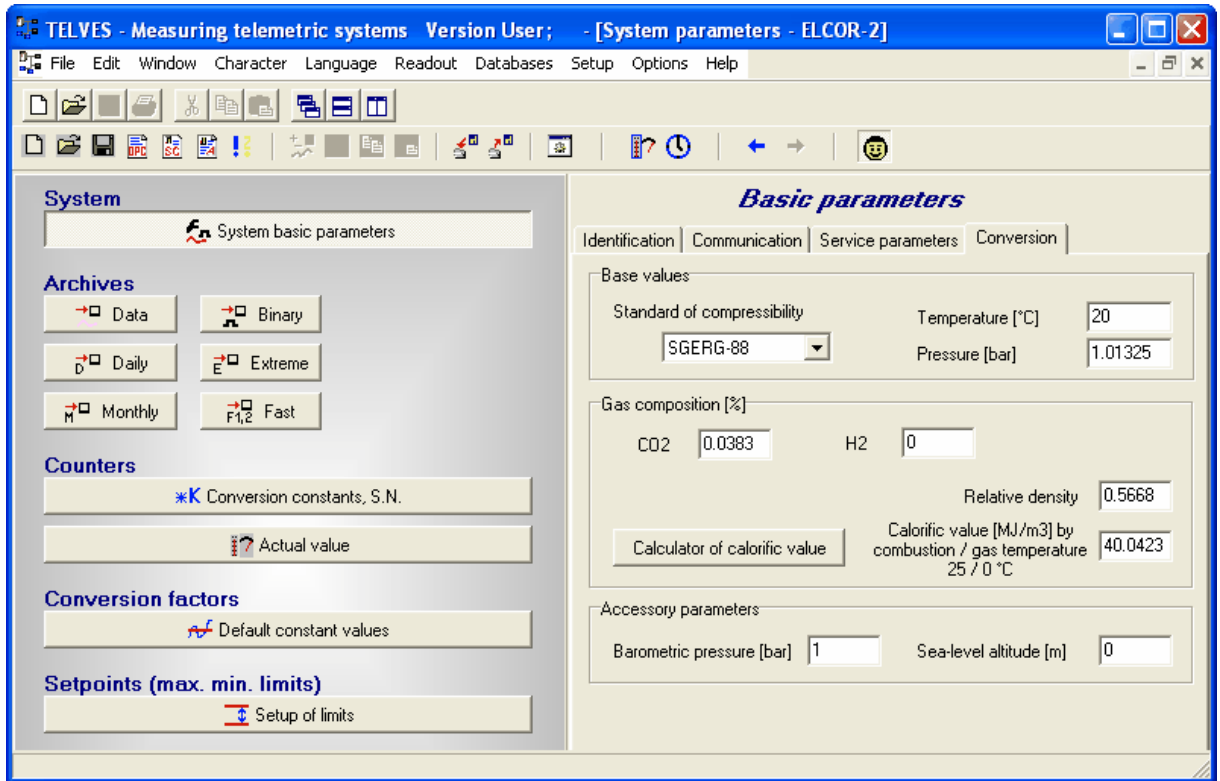

Fig. 33 Base device parameters

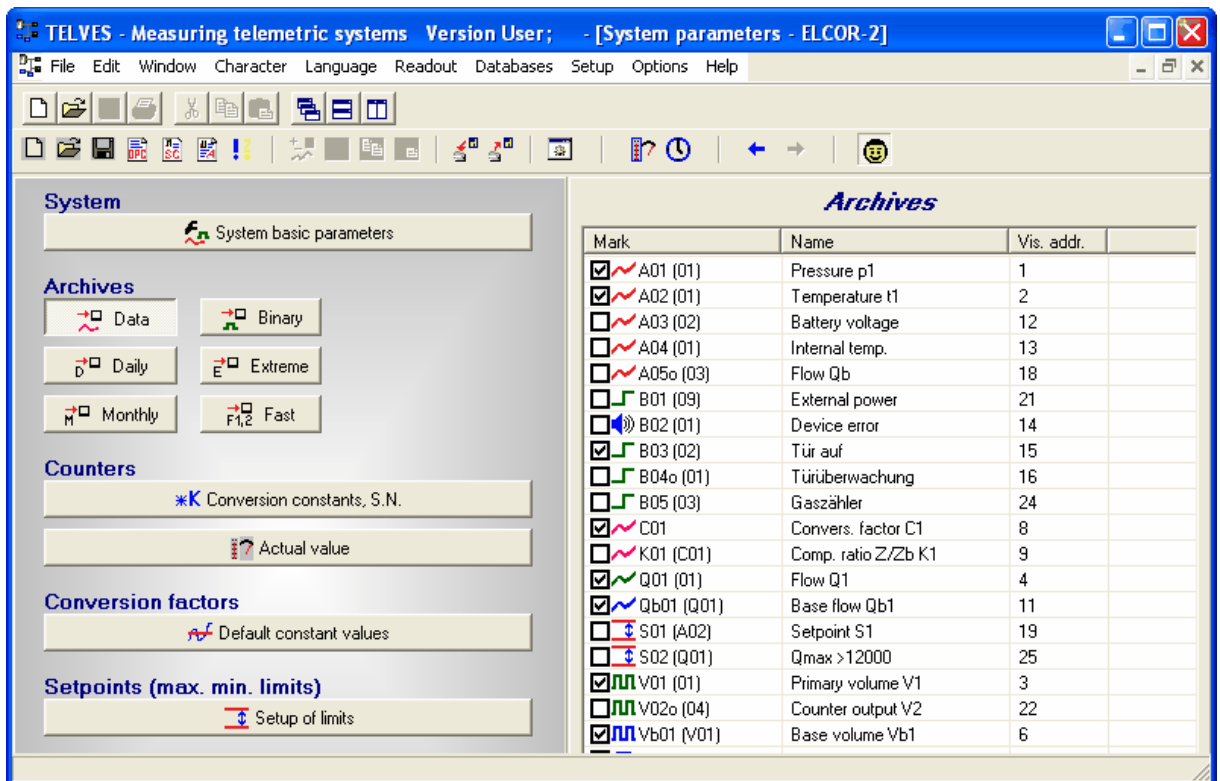

Fig. 34 Data archive

b) Full mode display

All parameters are displayed at tree order. This type of display is determined for advanced users.

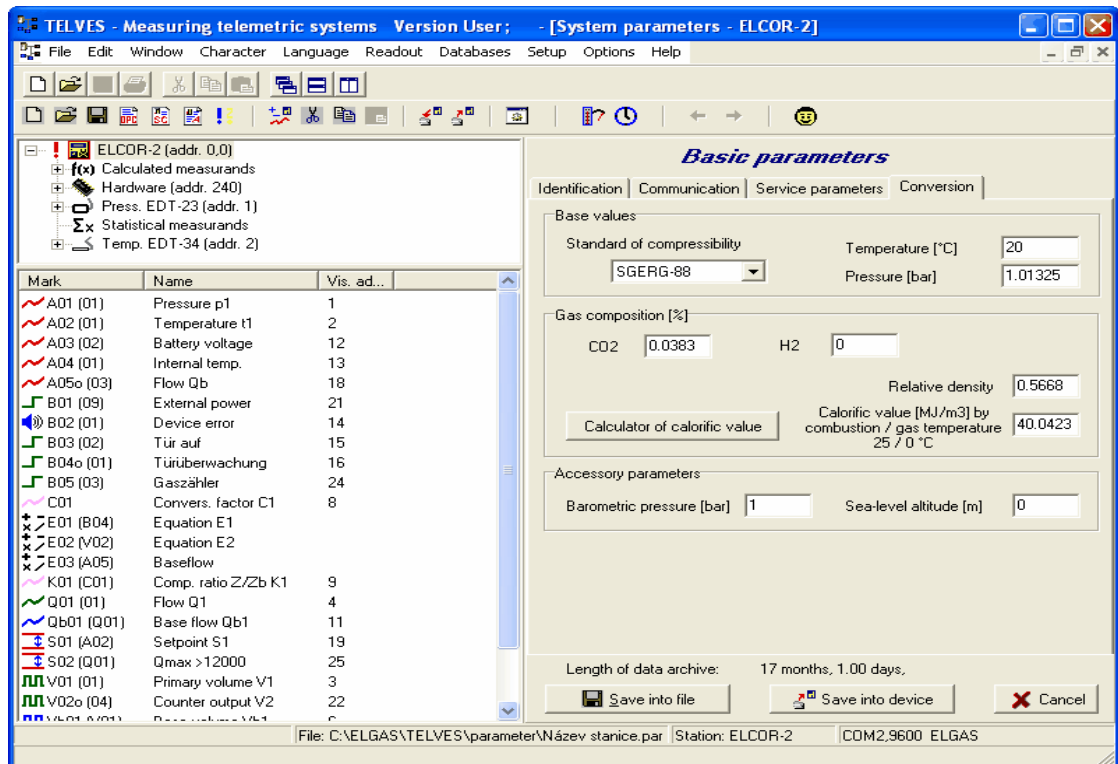

Fig. 35 Base parameters – Full mode display

In base display is possible to set followings:

- System parameters – allows identification settings, communication settings, service parameters setting and setting of parameters for conversion.
- Structure of individual archives. With simply check mark are assigned (or removed) single variables from format of relevant archives.
- Actual values of counter – with help of this are possible to preset volume values and conversion constants values.
- Error values of temperature, pressure and constant value for fixed conversion number.
- Setpoints or setting of boundary limits, if these limits already exist.
- Output pulses – permission or blocking of already defined output pulses generating

Values modification is made out with data assignment in the column „**Value**“ or in some cases with choosing of preset value. Changed data are saved in to the PC memory. Record into the device is made out after parametrization ending and with pressing the button „**Save into device**“.

Warning:

In some cases (a, b) may change of the setting effect clearing of some archives.

14.3.5 Device parametrization with assistant

For better device parametrization is in the device users-friendly and simple assistant. User may start up this assistant with click on the icon in the toolbar (see Fig. 36). With selection of **Installation of telemetric system** in **Wizard for editing of parameters** start base device parameters setting.

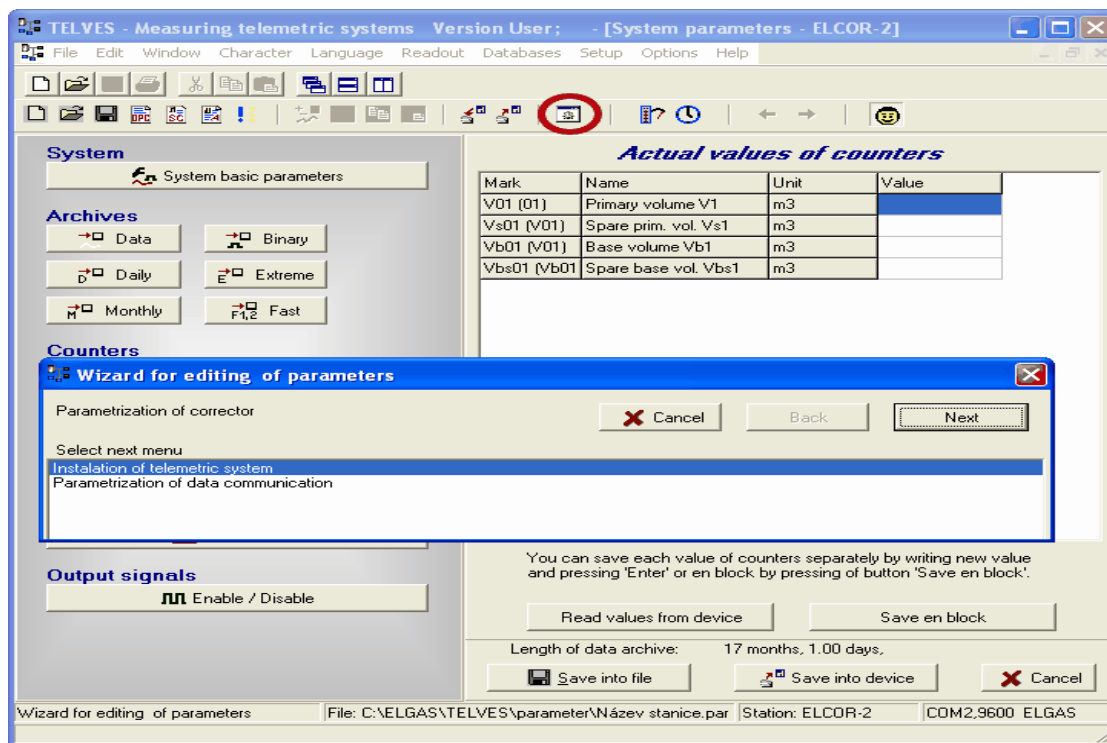

Fig. 36 Assistant for parametrization

Parametrization assistant guides the user through setting of some parameters. Meaning of all parameters is described on lower window frame.

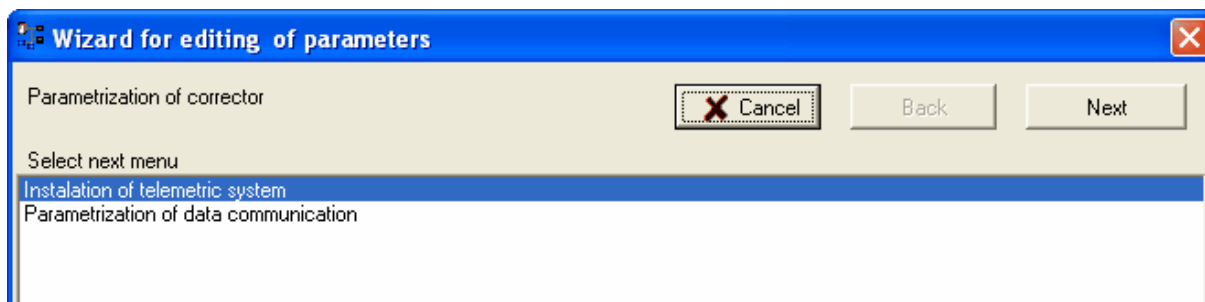

Fig. 37 Parametrization of identification and communication

On first screen is possible to set station identification number, station address in the network by force of Address1 and Address2, communication protocol, communication speed, period of saving into archives and measuring period.

Value range of parameter **Address1** is form 0 to 65535, for **Address2** is from 0 to 255. For **MODBUS** protocol is range of parameter **Address1** limited from 1 to 247; **Adresa2** is not used.

After pressing the button **Next** will be displayed following screen, which is determined for setting of **Gas** composition. Firstly must be chosen **Standard of compressibility**. According to chosen method is in the device preset gas composition from the manufacturer. User may set gas composition according to actual values.

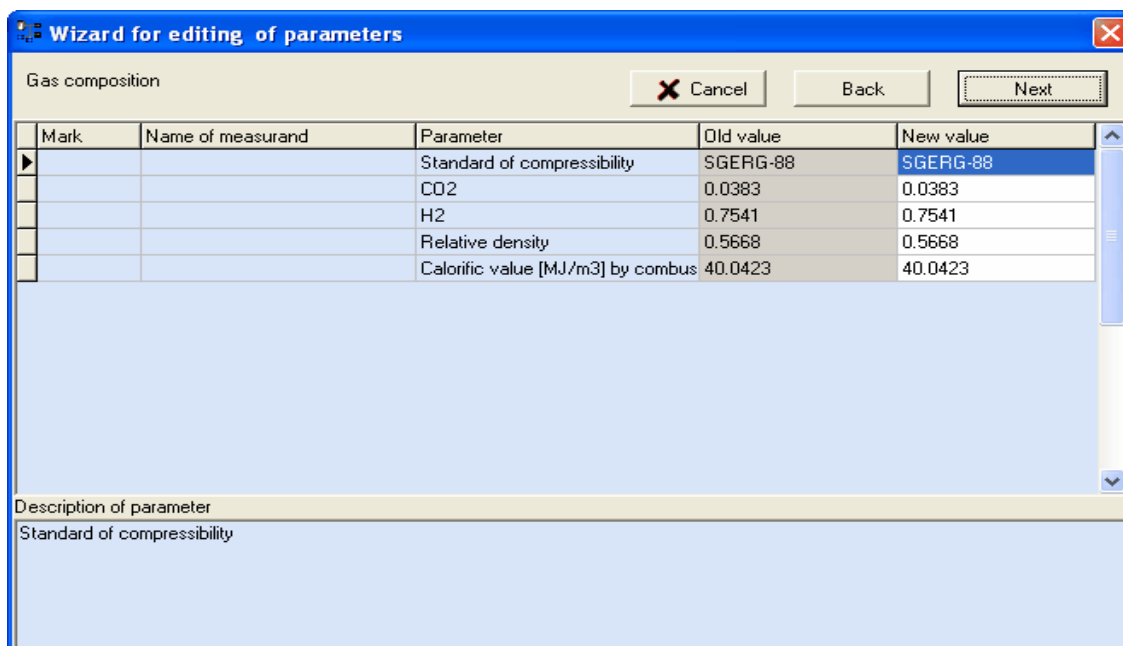

Fig. 38 Gas composition parametrization

Note:

Parameters are changed according to chosen compressibility in the first line. In case of constant value of compressibility value of this parameter is configured in following steps (see Fig. 39).

After pressing the button **Next Setup of 1. channel** or **Setup 2. Channel** follows.

On this screen is possible to set following channel parameters:

- **Gas meter** is set in first line **V01, Q01 Primary volume V1, Flow Q1** and is marked **Input pulse /Base unit**. Set value is good for volume V1 counting and for Flow Q1 counting. If gas meter has HF output, then is the range limited only on decimal multiples
- **Gas meter serial number** is set in the line **V01 Primary volume V1** and is marked **Serial number**
- **Error or default pressure value** is set in the line **C01 Convers. factor C1** and is marked **Default const. pressure**. Default pressure value is used in calculation of error volume value by sensor error.
- **Error or default temperature value** is set in the line **C01 Convers. factor C1** and is marked **Default const. temperature**. Default temperature value is used in calculation of error volume value by sensor error.

Setting of default compressibility constant is set in the line **C01 Convers. factor C1** and is marked **Default const. compressibility**. This compressibility value is used in calculation only if there is no compressibility calculated according to mathematical methods.

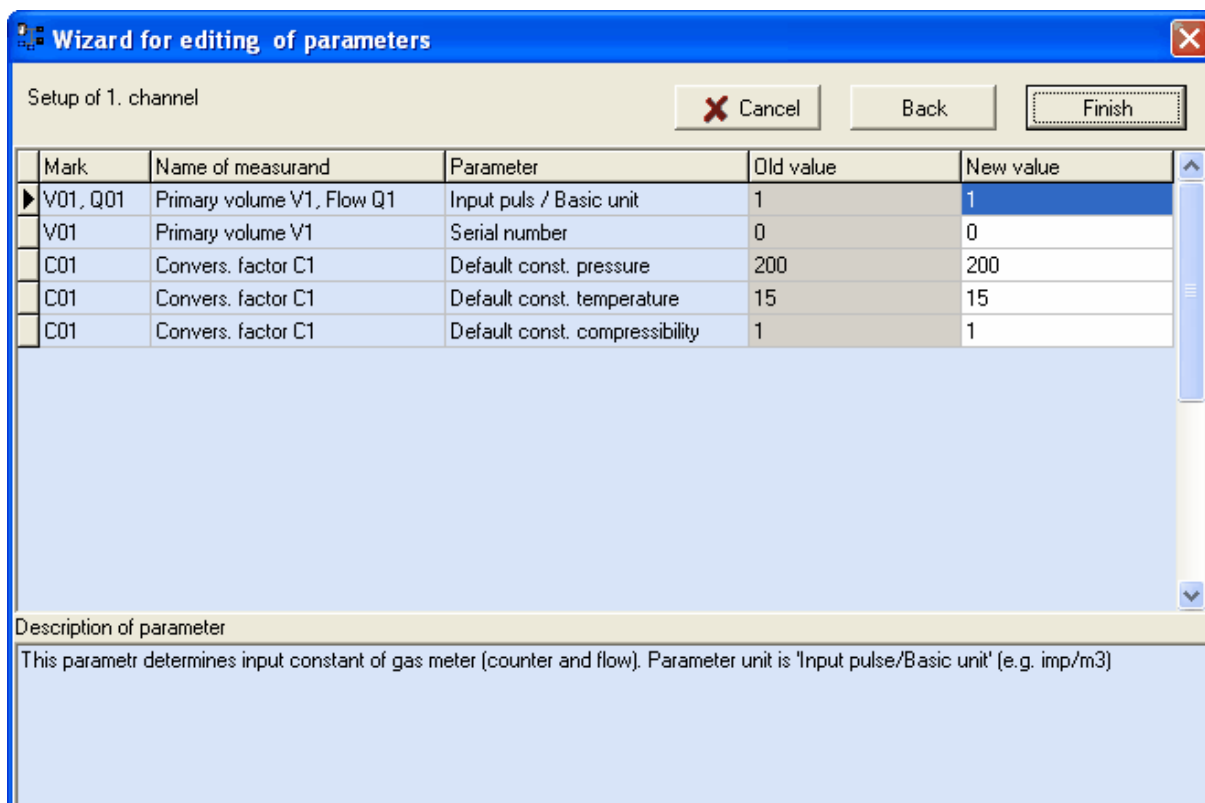

Fig. 39 Channel setting

With pressing the button **Next** follows analogous screen **Setting 2. channel**.

This is the last step of **Assistant for parametrization**. Another setting is necessary to make in the screen of displayed parameters.

Note:

After closing of wizard for parameterization there are parameters prepared in computer pattern for writing into device. Therefore do not forget write into device using button „ Save into device“ before closing of this page. For successful parameters writing into device is necessary to have the service switch in position „**On**“. After parameters saving switch over the service switch in „**Off**“ position.

14.3.6 Setting of primary volume counter

It is very important to make reconciliation of volume counters (e.g. reconciliation of primary volume with volume of gas meter counter). In the screen which shows

device parameters (Fig. 40 – simply parameters display) choose **Actual value** and in the column **Value** write required data.

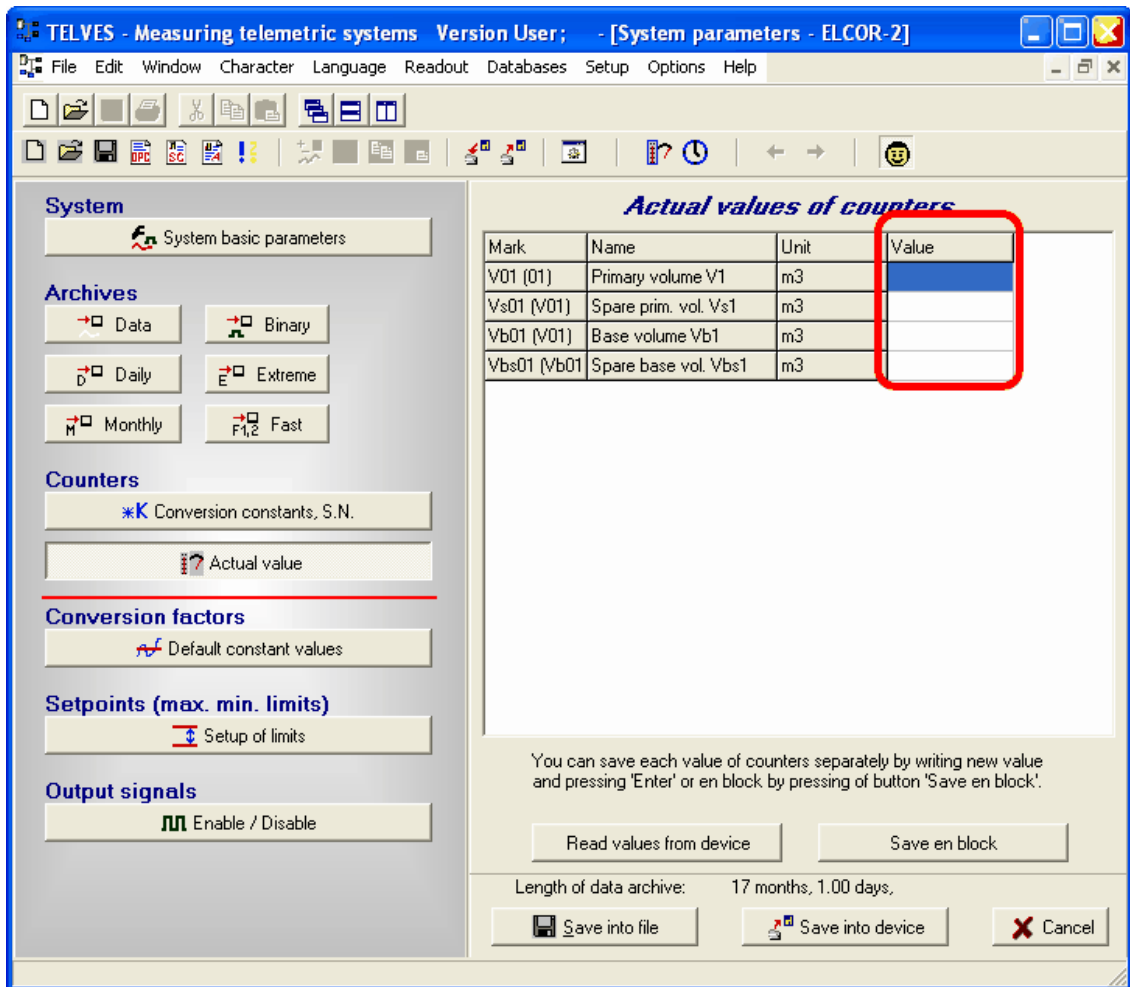

Fig. 40 Primary volume counter setting

It is possible to make complementary setting of binary inputs, outputs and limit values of measured quantities. If you switch over the service switch into position „Off“ the device will be ready for measuring.

14.3.7 Device diagnostics and summary status clearing

Device diagnostics may be done: a) by force of device keyboard
b) with help of service SW.

- a) In menu „**Diagnostics**“ are saved information about device condition:
- „**Current status**“– shows current device status. With pressing the button „**Right arrow**“ there are displayed all actual errors of the device one by one.
 - „**Summary status**“ – serves for instance for monitoring of active conditions of single device bit status from last summary status clearing.

- „*Init. sum. stat.*“ – serves for initialization (clearing) of summary status.

b) In SW on PC (Fig. 41)

Menu choice „**Setup -> Diagnostics (status) of the device -> From device**“ will be read out from connected device summary status and status after last device test. (For displaying of diagnostics from saved data choose **From file**). It is possible to find out current status of the device with pressing the button **Device test**.

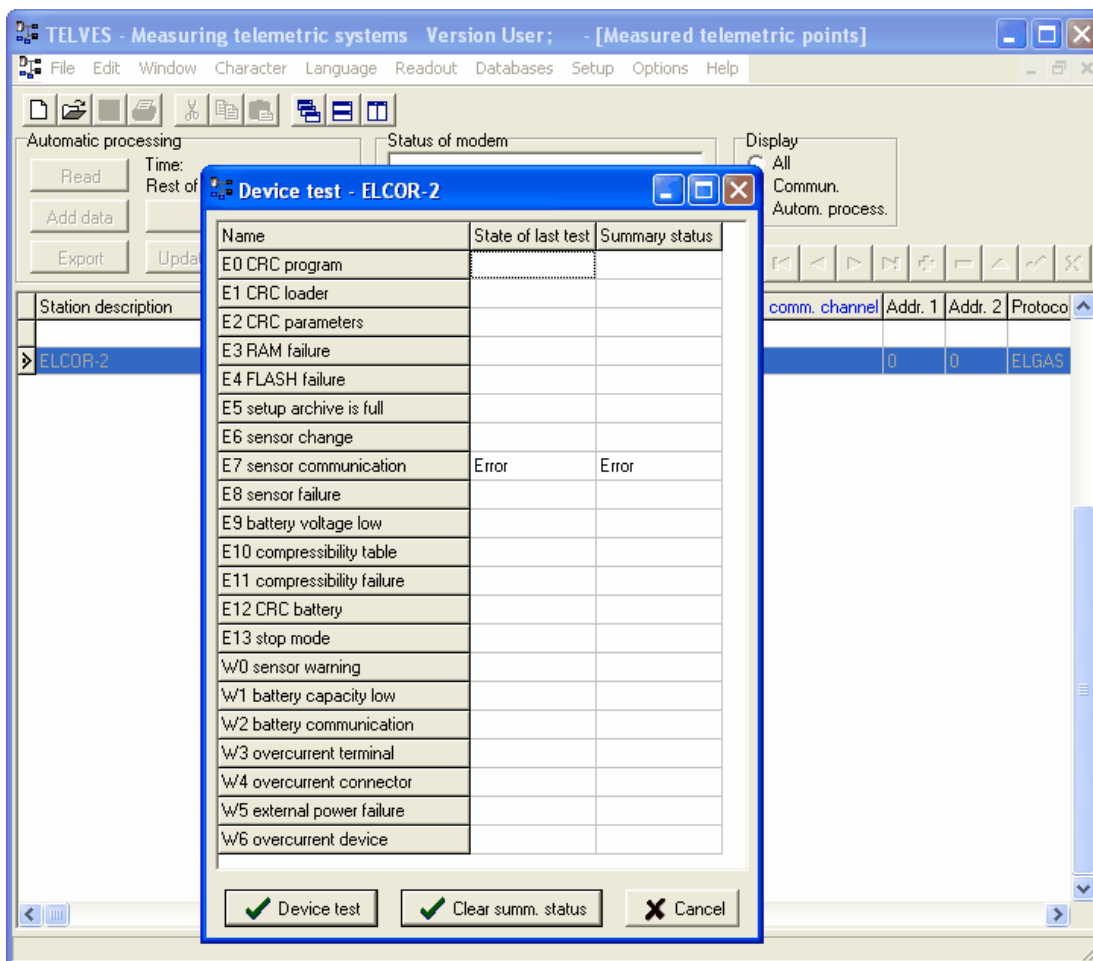

Fig. 41 Displaying of device diagnostics

In column „Summary status“ there are captured again all errors from the last reset of summary status. The central button at bottom part of window can be used for reset.

Table with description of errors and warning messages and pertinent procedures how to remove it are shown in charter 16.

14.3.8 Archives clearing

This operation may be made only with help of service SW. Choice in menu (see Fig. 42) is possible to clear archives selectively or all archives with one order (except Setup archive).

Warning:

Deleted data in archives cannot be refreshed.

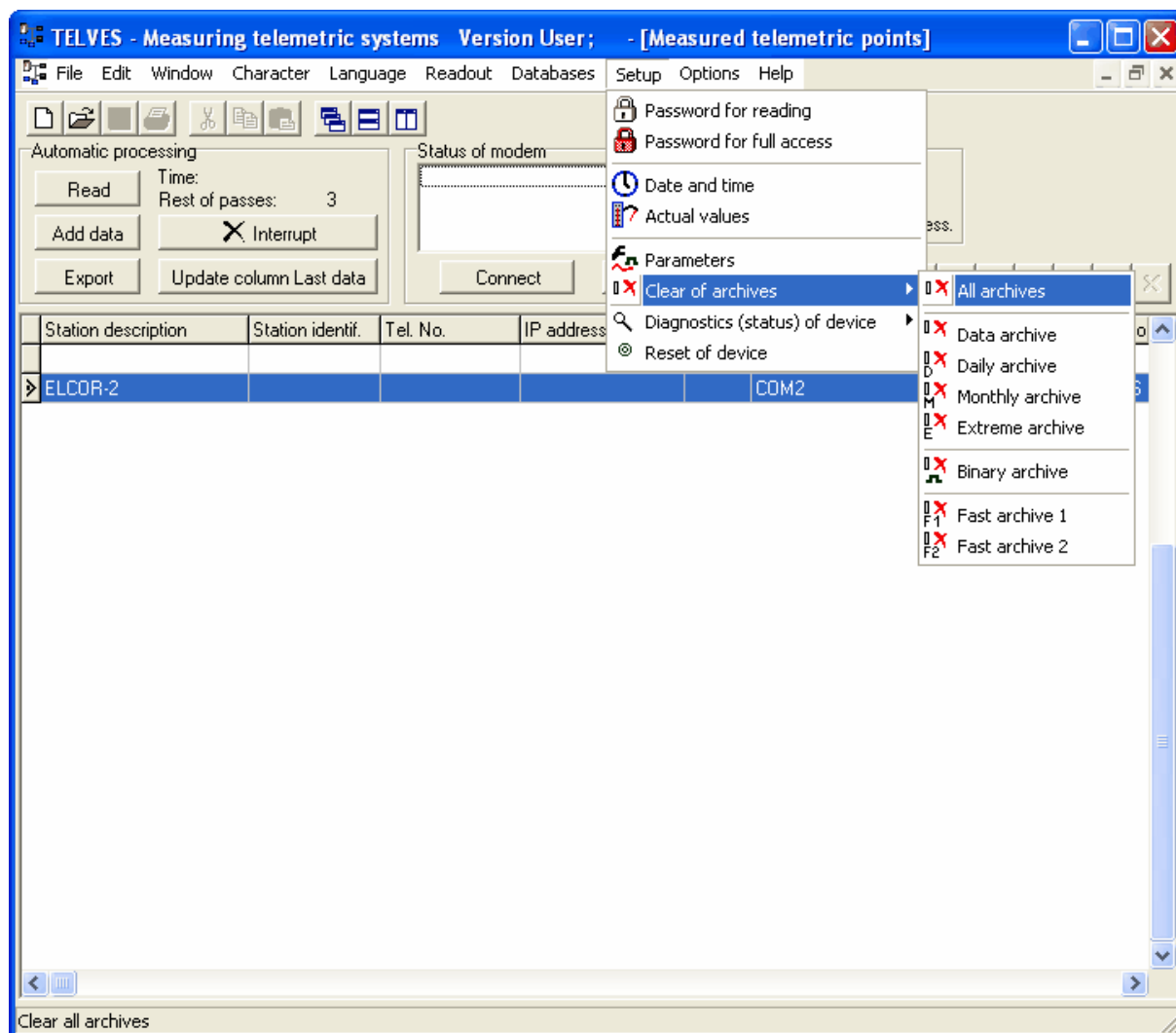

Fig. 42 Device archives clearing

14.4 Password in the device

It is possible to use device either without passwords or with password protection. Password may be set by force of service SW. It is possible to set password for reading and for full access. The device asks for inserting of passwords only if passwords are activated.

- With password for reading is possible to readout data from the device.
- Password for full access allows to readout data and writes data into device.

Password for full access merges both rights of passwords for reading and for full access. Service SW remember password till its restart, so it is not necessary to enter the passwords again during reading or writing. Passwords may be set in menu

Setup → Password for reading; Password for full access.

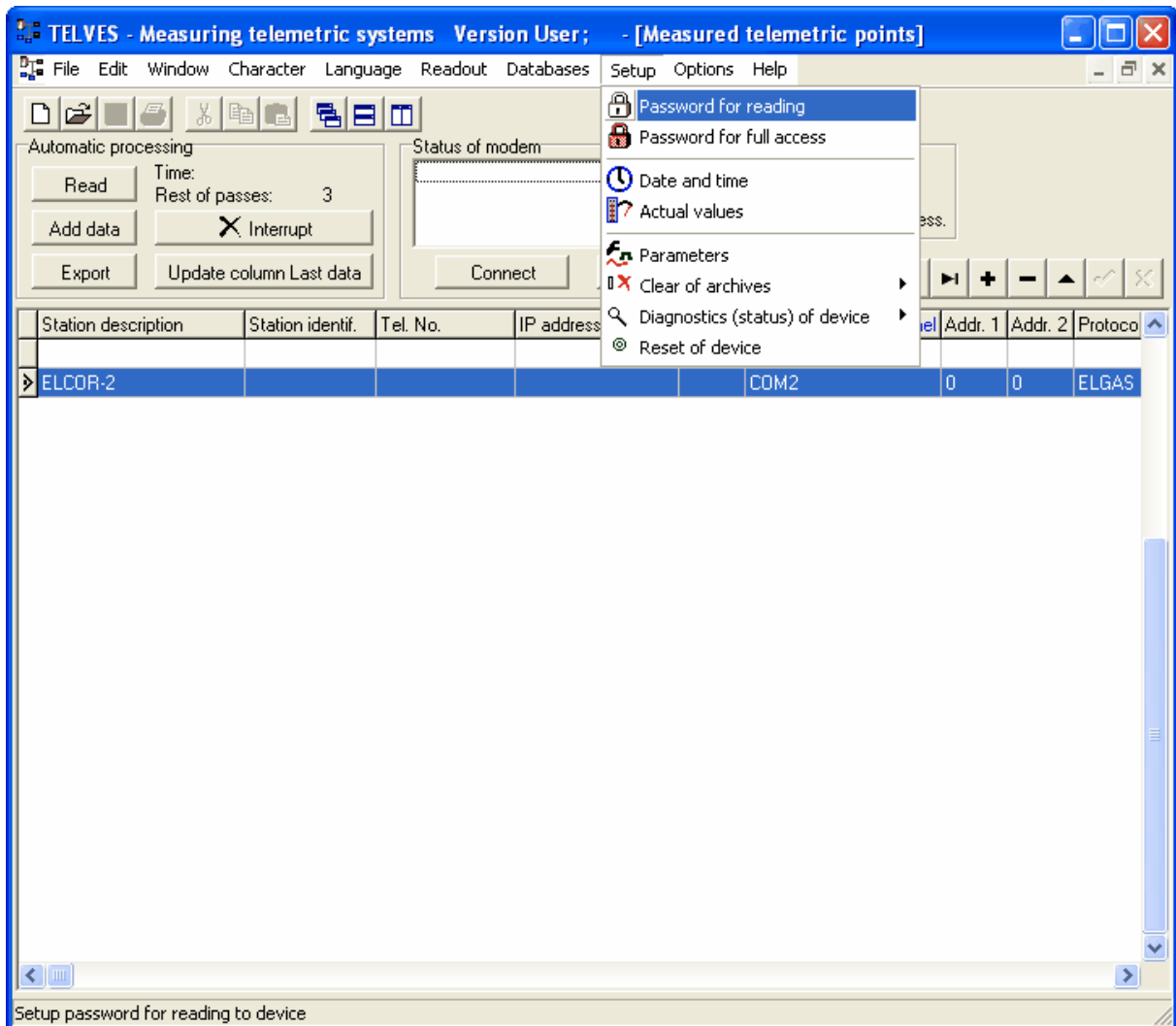

Fig. 43 Password setting

Note:

1. The password will not be activated If you fill up “empty” password during password setting.
2. Maximal length of password for reading and for full access is 6 characters.
3. Password system can be changed by administrator – password allocation or user’s password change (see SW manual).

15 Configuration examples

In this chapter there are the most common device configuration examples. User may deduce standard progresses of device setting according to user's requirements. Device configuration is made out by force of service SW.

Firstly must be displayed file of device parameters:

- 1) Parameters displaying of the device which is connected to PC:
menu **Readout -> Parameters**
- 2) Displaying of parameters which were readout form the device in the past:
menu **Setup -> Parameters** (select saved file with suffix *.par)

Notes:

- 1) Changing of parameters is made in computing memory of PC. It is saved into device after pressing the button **Save into device**.
- 2) Described examples of configuration may do (except point out exceptions) users without hardware key. For successful parameter saving is necessary to have service switch in „**On**“ position. After finishing of parameters adjusting is necessary to switch the service switch back to „**Off**“ position.

15.1 Device parameters displaying

In service SW is possible to choose between two types of device parameters displaying:

a) Simple mode display

On the screen are displayed base device parameters with possibility of its setting.

b) Full mode display

All parameters are displayed at tree order. This type of display is determined for advanced users.

It is possible to switch between both types of displaying with help of icon  , which is placed on toolbar (see Fig. 44). Default type of displaying is possible to set in menu **Options -> Programme parameters -> Other parameters**, choose **Simple variant of parameter setup**.

Described types of parameters settings are for both types (if is it possible).

15.2 Gas meter constant setting

It is necessary to set gas meter constant (in service SW marked as a relation pulse input/base unit) during installation on consumption place or after gas meter replacement. Values range depends on type of gas meter output – LF output or HF output.

15.2.1 Simple mode display

In this paragraph is described setting of gas meter constant in simplified display. Into column S.N. in the line primary volume write gas meter serial number.

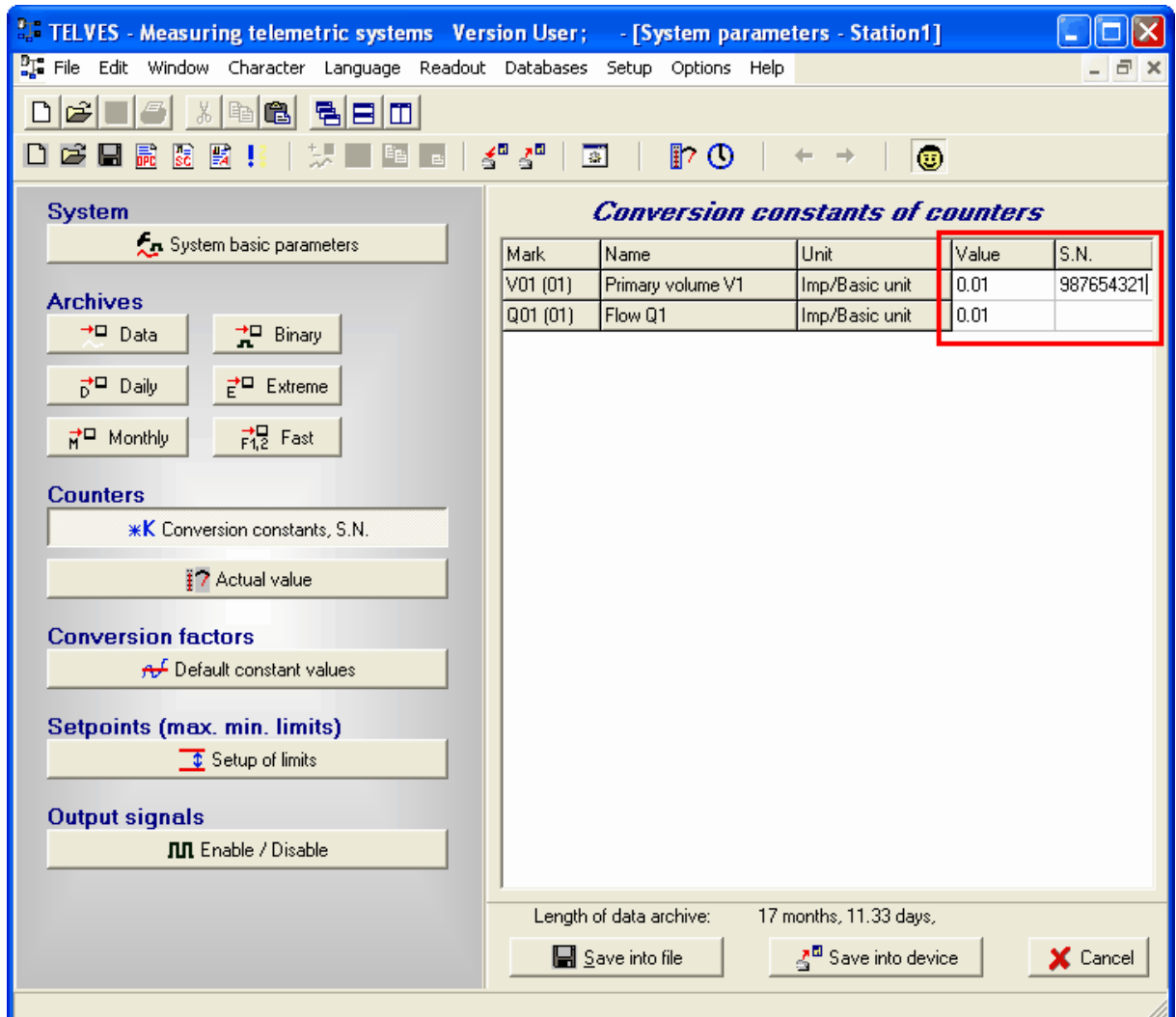

Fig. 44 Gas meter constant setting in simple mode display

Value of constant by item V01 is automatically copied into item Q01. The same rule stands for V02 a Q02, because this constant is used for counting of both quantities.

15.2.2 Full mode display

It is necessary to make setting separately for:

- a) – counting of **Primary volume V1** (or V2)

b) – counting of **Flow Q1** (or Q2).

In this display mode is constant chosen for one parameter (V) not used automatically for second parameter (Q).

Warning:

Practically it means that we can have for V and Q two different constants.

Example 1 – Gas meter with LF output:

Program allows setting constant of gas meter with LF output in range of followings values: 0.01, 0.1, 1, 10, 100 or 1000 pulse/m³. Set value must be written into field **Input pulse/Basic unit**. Progress for Primary volume V1 is displayed on Fig. 45. The same progress is used for Flow Q1.

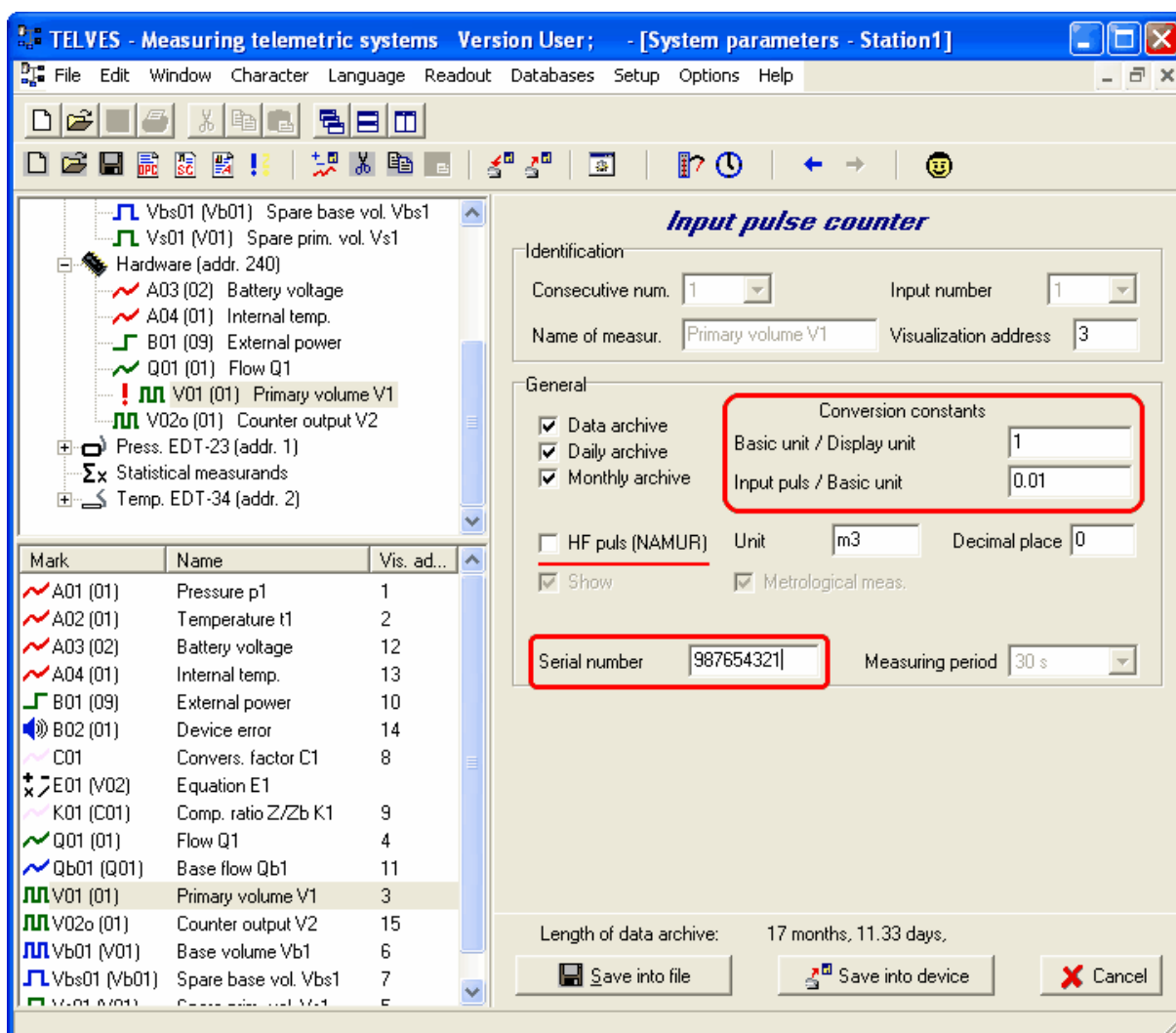

Fig. 45 LF gas meter constant setting in full mode display

Example 2 – Gas meter with HF output

For gas meter with HF output **HF pulse (NAMUR)** must be ticked on. Fig. 46 shows setting of gas meter with HF output constant on value 82.5564 pulse/m³ and serial number of gas meter 987654321 for primary volume V1. Here is also necessary to make same setting for Flown Q1.

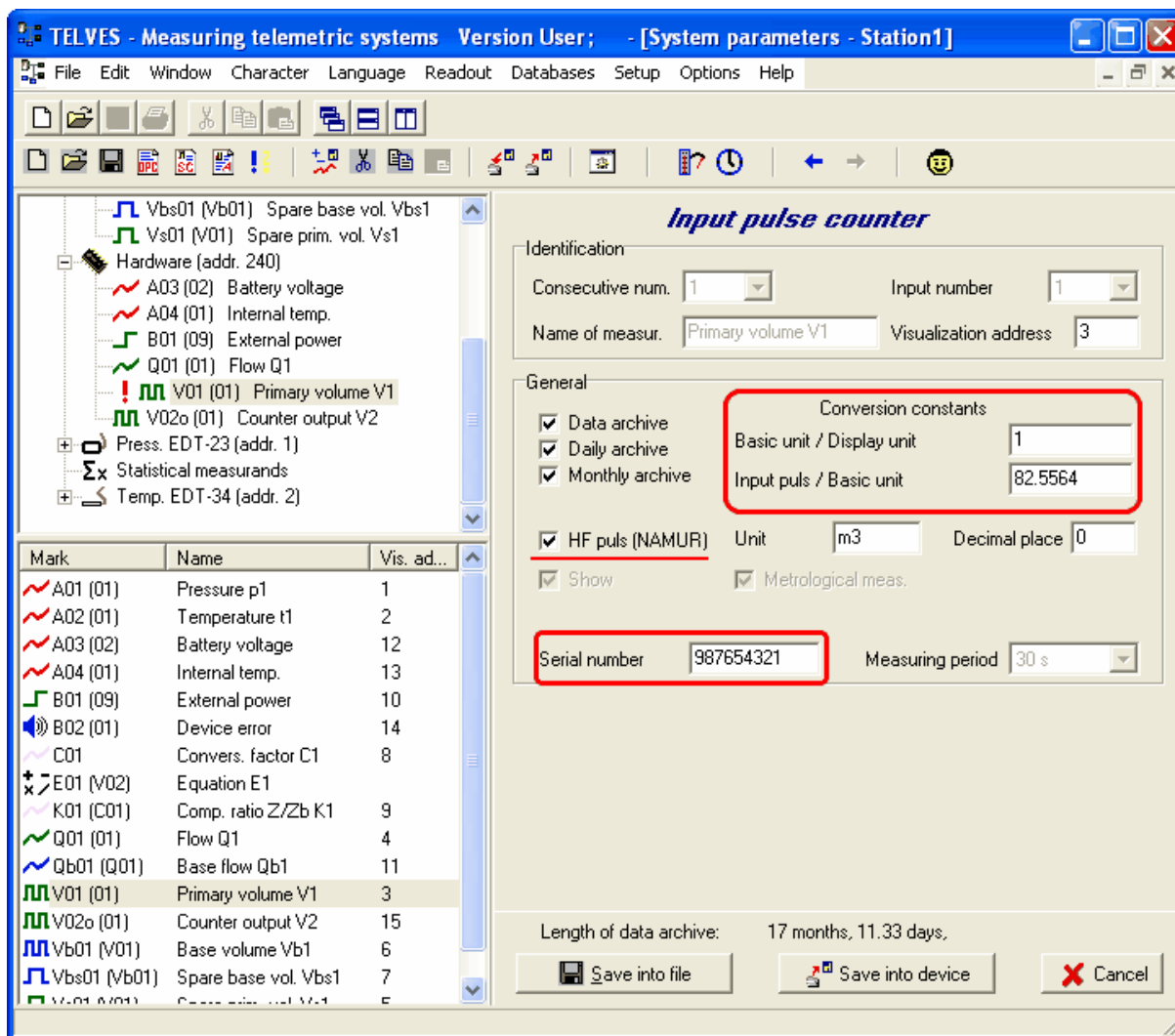

Fig. 46 Setting of gas meter with HF output constant in full mode display

15.3 Pulse outputs setting

Pulse output may be used e.g. for direction of odorization, preheating or as an output for another managing systems, dispatching, etc.

15.3.1 Simple mode display

To set this type of output it is possible only in case, that this output was already configured in full mode display. Then is possible (in simple mode display) to switch on or switch off by force of the button **Output pulses, binary** (see Fig. 47).

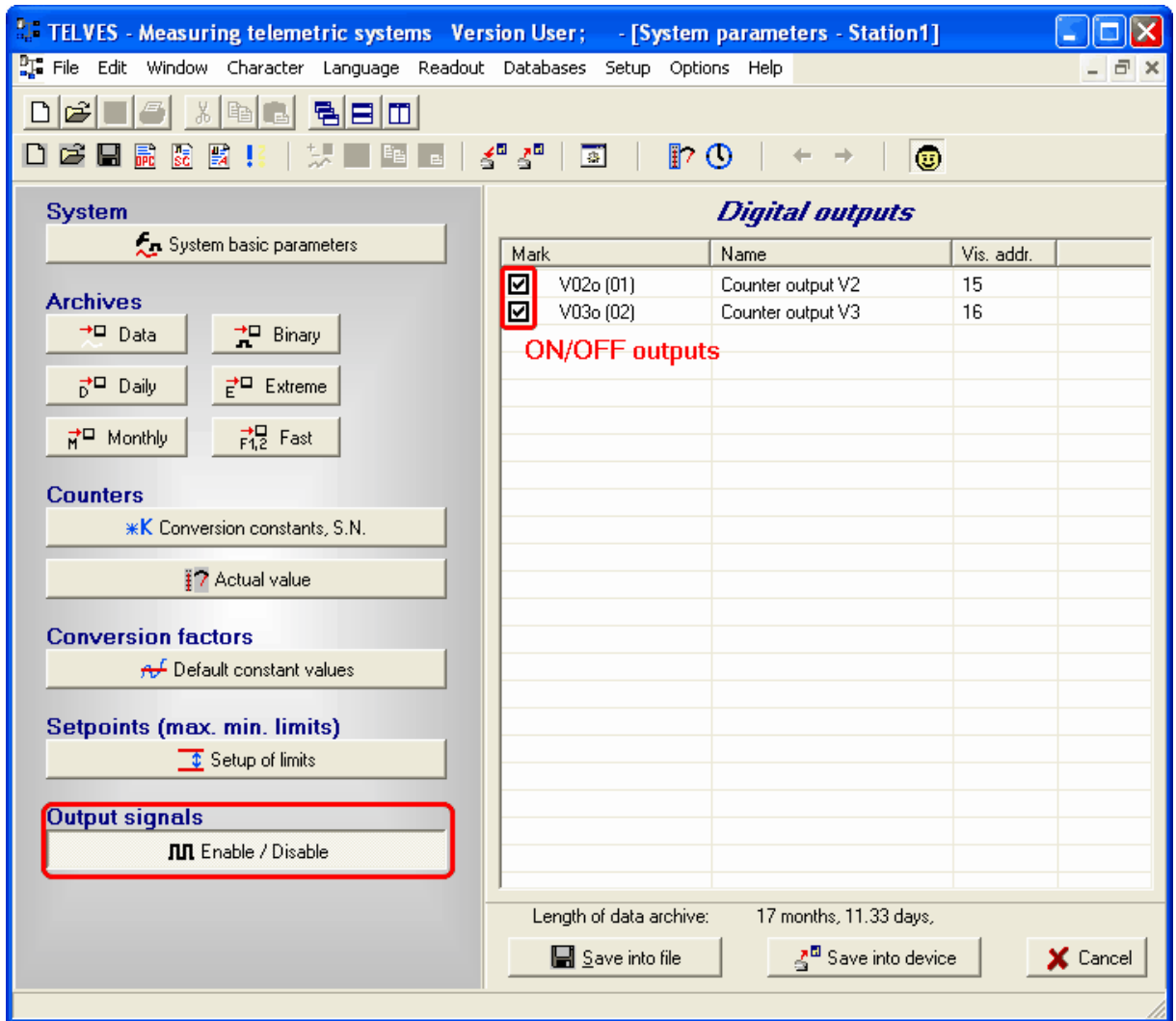

Fig. 47 Output pulses, switching on and off

15.3.2 Full mode display

In case that this output was not configured it is necessary to activate it and assign a quantity (representing pulses). It is necessary to set technical parameters of output pulses as well.

1. Output inserting into parameters

In left upper window choose item **Hardware**, press right mouse button -> **Insert output measurand** -> **Counter (pulses) output measurand** (Fig. 48).

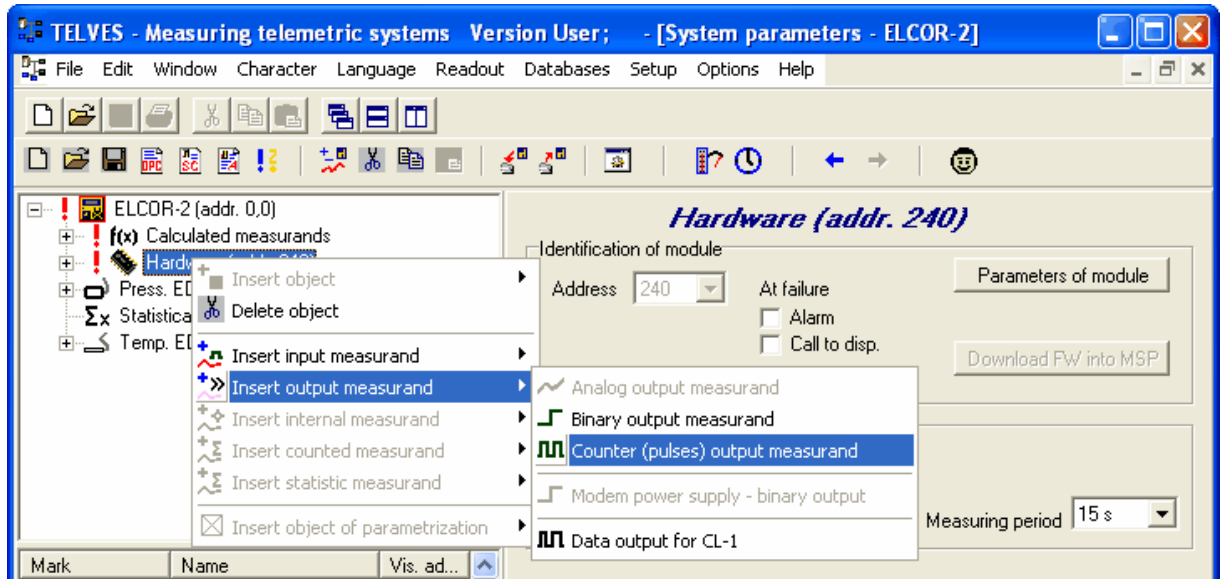

Fig. 48 Pulse output inserting

Then card of **Pulse output counter** will be created e.g. with indicated V03o (see Fig. 49).

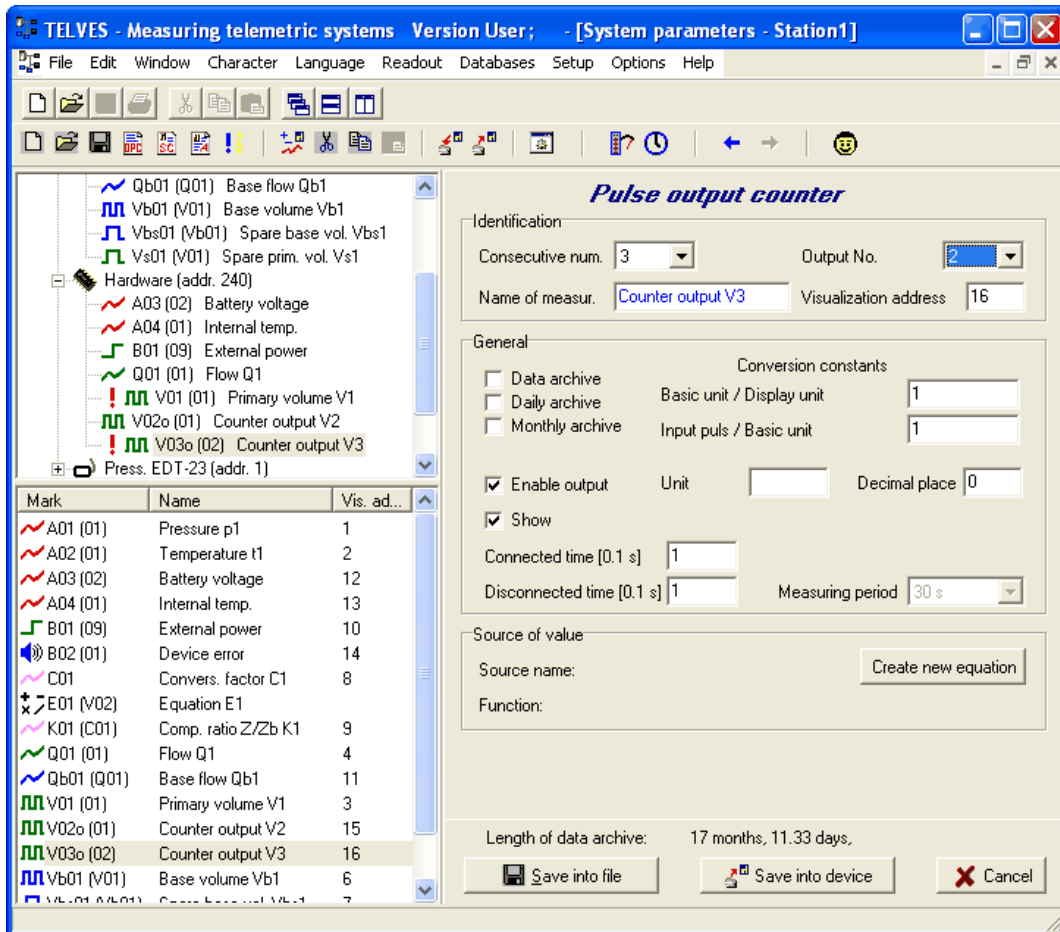

Fig. 49 Pulse output parametrization

Now is activated hardware pulse output. The device offers possibility of four digital outputs. These outputs are lead out on clamps (DO1 to DO4) of OUTPUTS terminal block inside the device. Item **Output No.** indicates on which clamps of OUTPUT terminal block is this output connected:

Output No. 1 – clamp DO1

Output No. 2 – clamp DO2

Output No. 3 – clamp DO3

Output No. 4 – clamp DO4

The programme assigns automatically free output clamp (in our example DO2). But it is possible to swap it.

2. Setting of output pulses properties

- **Connected time** – range of output pulse. Minimal range is 0.1 s. It is set in complete multiples of this value (for multiple 0 or 1 set the range always 0.1 s).
- **Disconnected time** – lag between pulses. Setting of this is the same like for connected time.
- **Enable output** – with this choice is possible to enable/forbid configured output (is the same like in simple display). This choice is not functional in devices with older version of firmware.
- **Unit** – here write the measure unit for output information (e.g. m³)
- **Basic unit / Display unit** – leave value 1
- **Input pulse / Basic unit** – leave value 1

3. Output measurand and output constant

Till now was not defined yet which measurand (e.g. primary volume of first channel or standard volume of second channel, etc.) should the represent pulses. In next step it is necessary to connect this output counter (V03o) on required quantity. Assignment of this quantity is made with help of tool equation. It can be made by pressing the button **Create new equation** in the frame **Source of value** with help of *Wizard for mathematic expression* (see Fig. 50).

This example creates the wizard object *Equation* (Fig. 51). In this case equation E02 is determines for output pulses of standard volume generating of the first channel (total of standard volume counter and counter of error standard volume). Equation is for output V03o. Mathematical expression defines input quantity (or input quantities). In this case looks the quantity like:

$$V03o = dVb1 + dVbs1$$

- it means that for output quantity V03o is input the sum:

dVb1 acquisition (d=difference) of standard volume V1 of the first channel. In case of primary volume there would be dV1.

dVbs1 acquisition (d=difference) of standard spare (s) volume V1 of the first channel.

If necessary apply this output on **output constant**, then the expression is filled with multiply of requested constant. E.g. if constant is 6.53, then it is necessary to customize the mathematical expression on:

$$(dVb1 + dVbs1) * 6.53$$

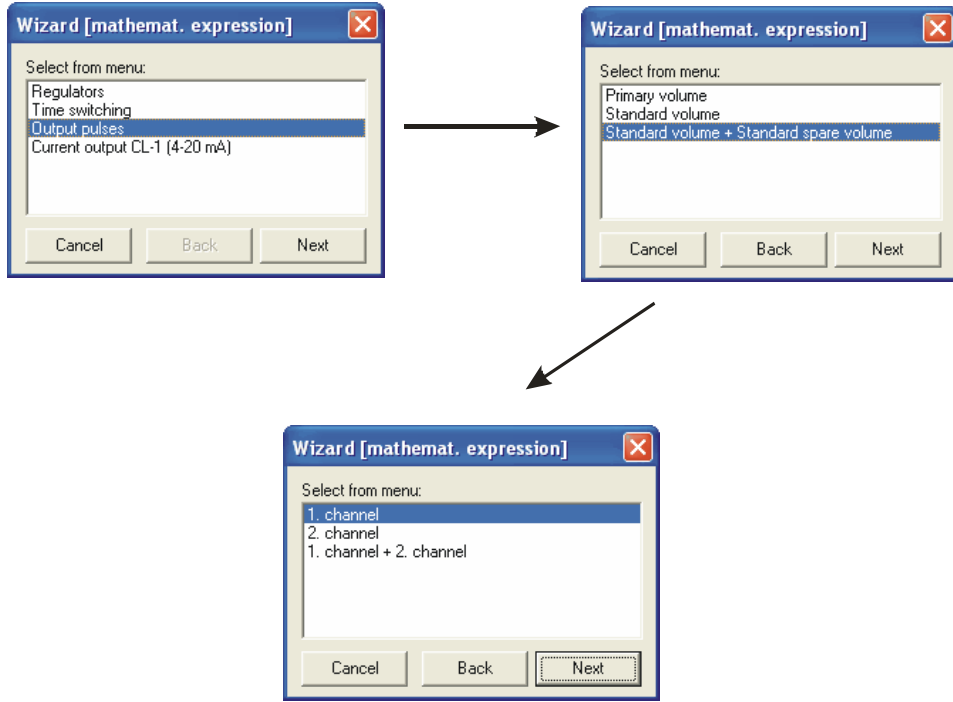

Fig. 50 Wizard for mathematical expression

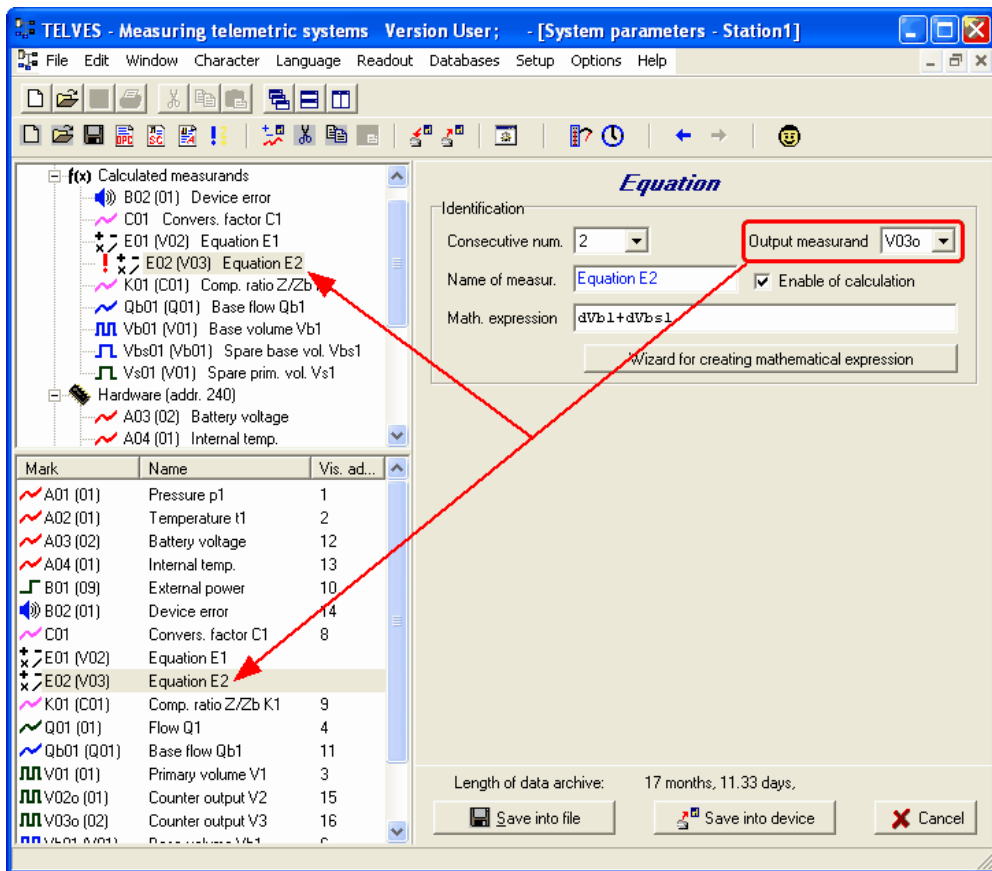

Fig. 51 Equation for primary volume pulses and output connection

After this setting related equation is by the V03 parameter displayed in the frame **Source of value**. To make some changes in equation press the button **Skip on source** (see Fig. 52).

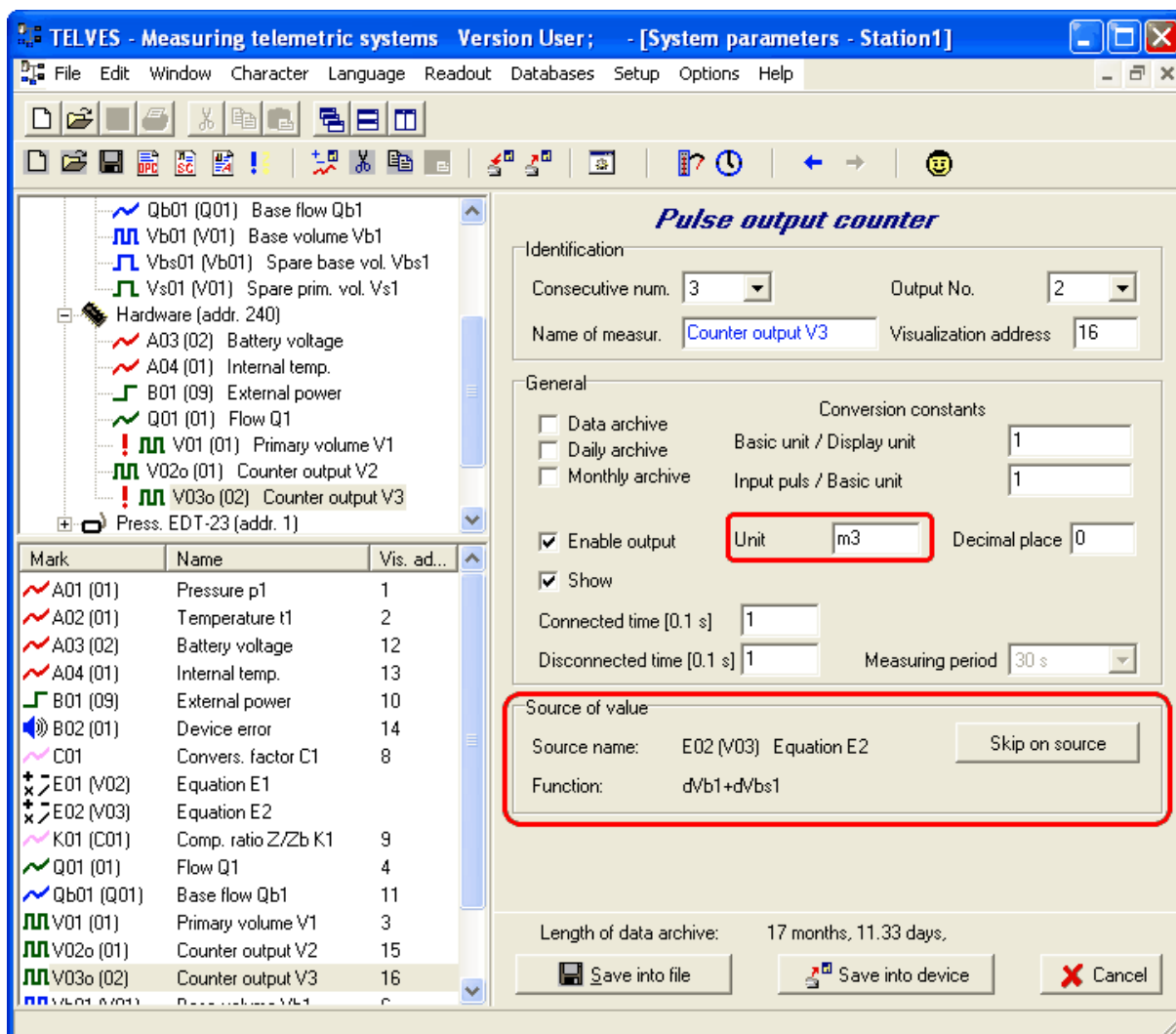

Fig. 52 Parameter V03 after equation assignment

15.4 Analogue output setting

Analogue output can be used e.g. for daily consumption displaying, for pressure in pipeline displaying or for flow displaying.

Analogue current output from the device (4-20 mA) is made with connecting of module CL-1 to clamp of digital device output (DO1 to DO4). Used digital device output must be configured for connection with module CL-1. Module CL-1 cannot be configured due to analogue output parameters are set in the device.

15.4.1 Simple mode display

In simple mode this output cannot be configured. Only in case that this output was already configured in full mode display. Then it is possible to switch on or switch off this output with ticking off/on (see Fig. 47).

15.4.2 Full mode display

This procedure is similar with the procedure for pulse output. From item **Hardware** (in left upper window) must be chosen **Insert output measurand** and then **Data output for CL-1** (see Fig. 53).

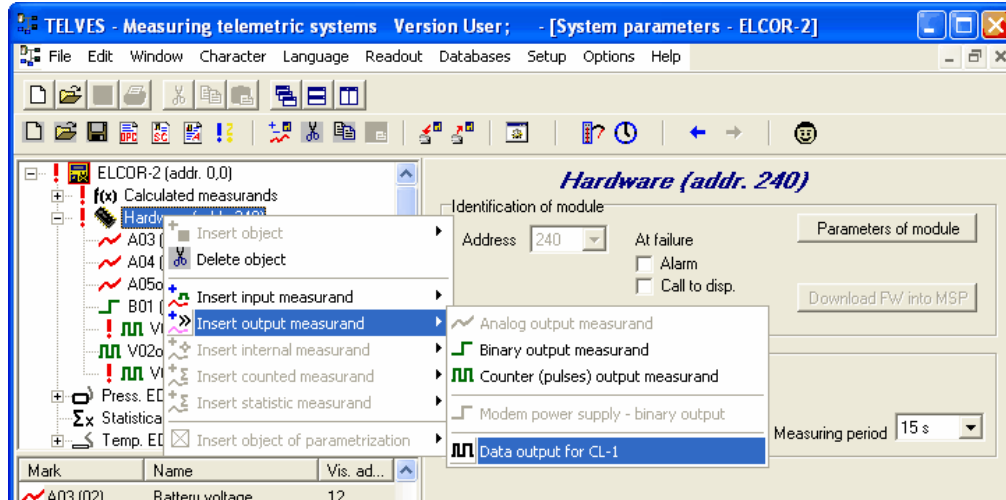

Fig. 53 Analogue output setting

On card **Analogue output** (see Fig. 54, parameter A05o) **Output number** gives appropriate clamp (from the range of the clamps from DO1 to DO4) where output signal will be sent to or where module CL-1 will be connected to.

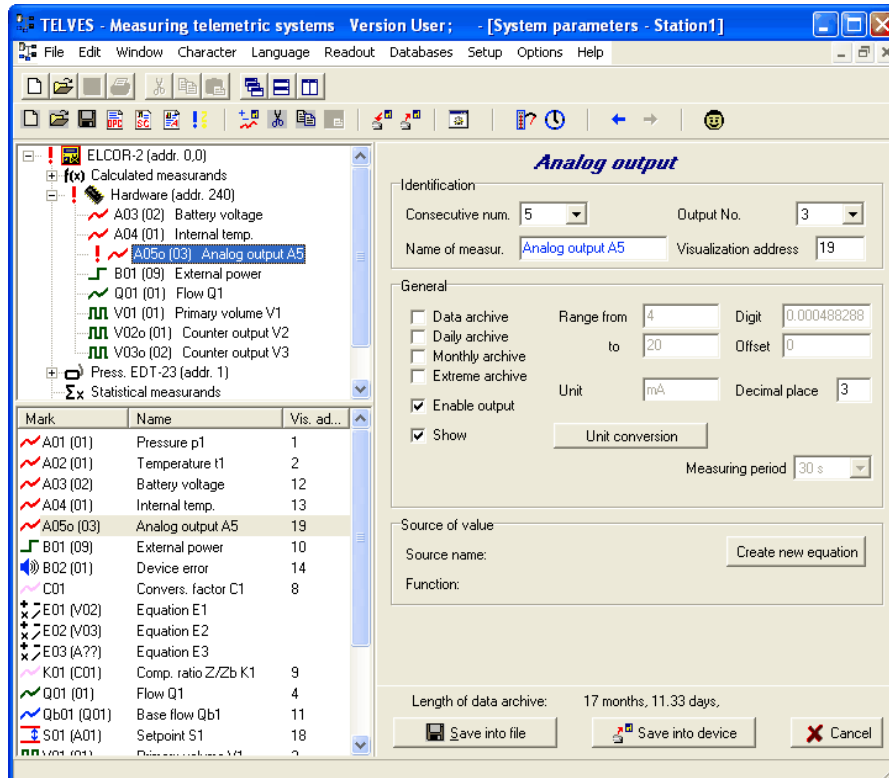

Fig. 54 Analogue output parametrization

In the following step it is necessary to press the button **Create new equation** again.

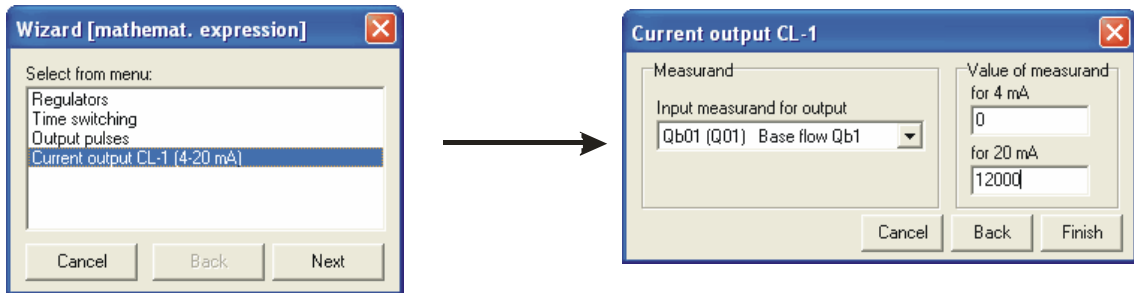

Fig. 55 Wizard for analogue output equation making

On the first screen choose **Current output**, on the second screen choose quantity which will be watched (e.g. Base flow) and then assign values of minimal and maximal limits for output current according to flow value. After wizard finishing will be displayed generated equation for analogue output (parameter A05 see Fig. 56).

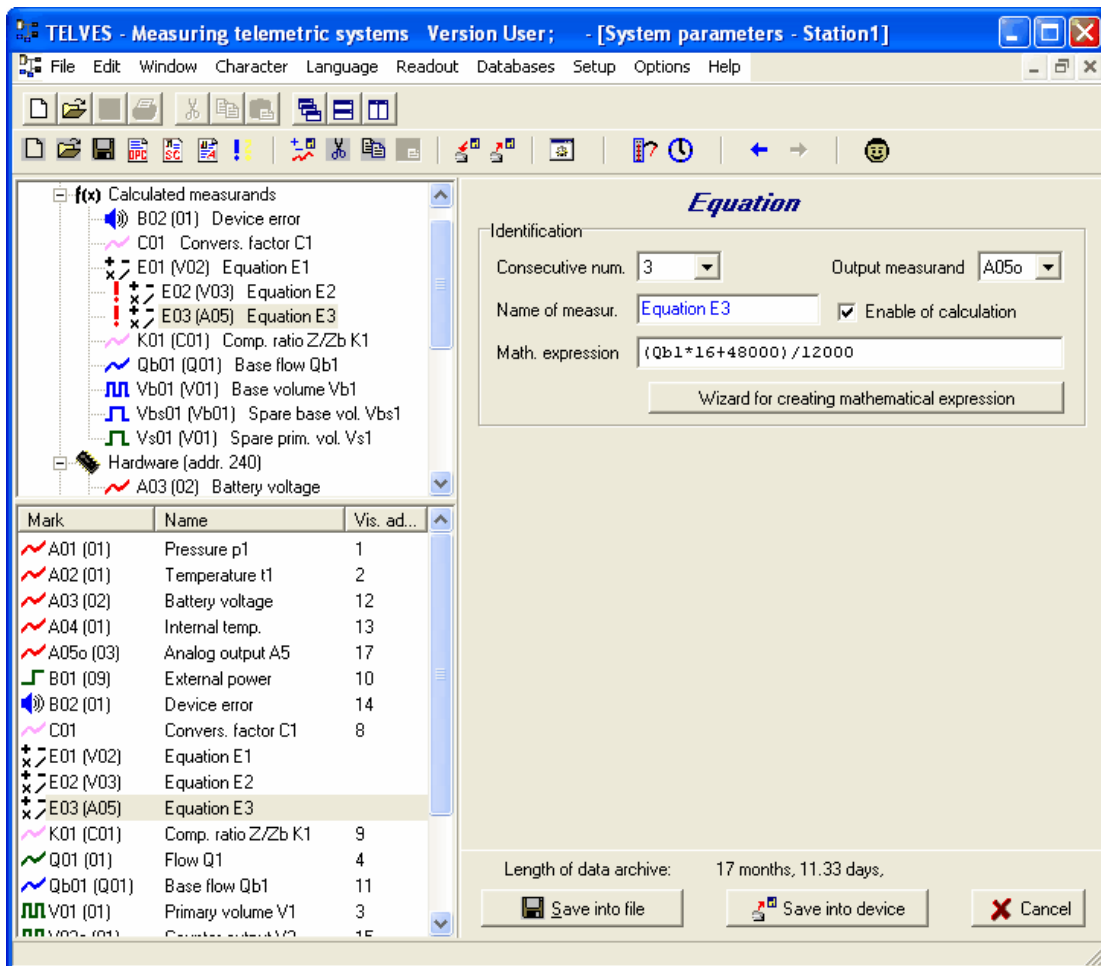

Fig. 56 Resulting equation and connecting of analogue output on counted quantity

Resulting form of generated equation is:

$$A05o = (Qb1*16+48000)/12000$$

Form equation is possible to see that for Qb1=0 is equation result A05o=4 mA and for flow Qb1=12000 is the result A05o=20 mA.

Resulting setting for analogue output A05 is on Fig. 57.

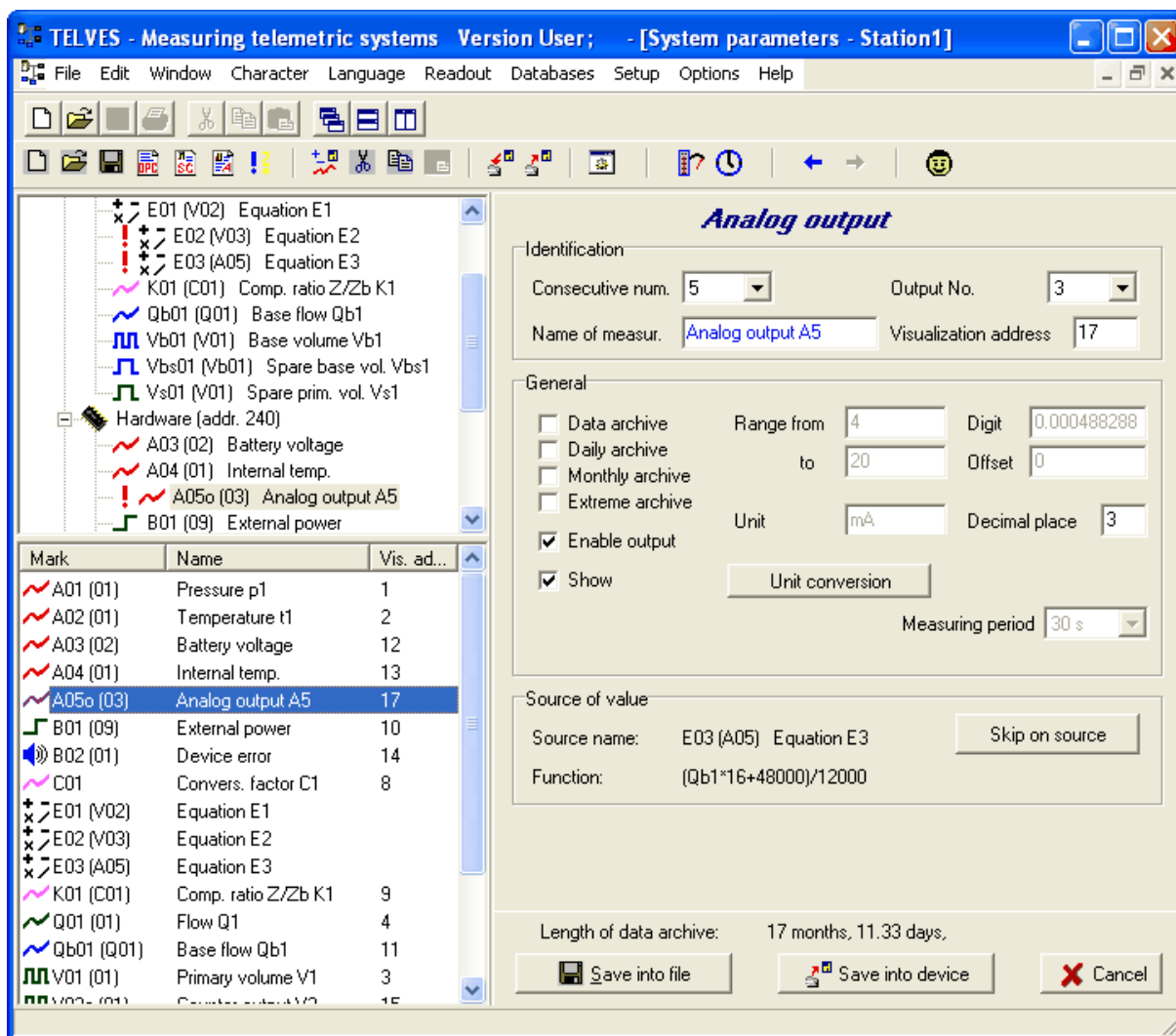

Fig. 57 Resulting setting of analogue output on output clamp DO3

15.5 Setpoint setting – limit values of measured quantity

In many cases watching of limits is very important during evaluating of measured quantities. Because of that it is possible to set in the device so-called **Setpoints**. Setpoints may be defined either as maximal or as minimal value of analogue quantity. In case that watched quantity will be over limit then can be generated record into data or binary archive. Also error condition can be activated or the device may automatically call superior system.

15.5.1 Simple mode display

In this type of displaying cannot be the output added into configuration of the device. But if the parameter was added in full mode display (see next) it is possible to set size of value.

15.5.2 Full mode display

In left upper window of displayed parameters choose item **Calculated measurands**. Press the right mouse button and choose **Insert counted measurand** → **Setpoint** (see Fig. 58).

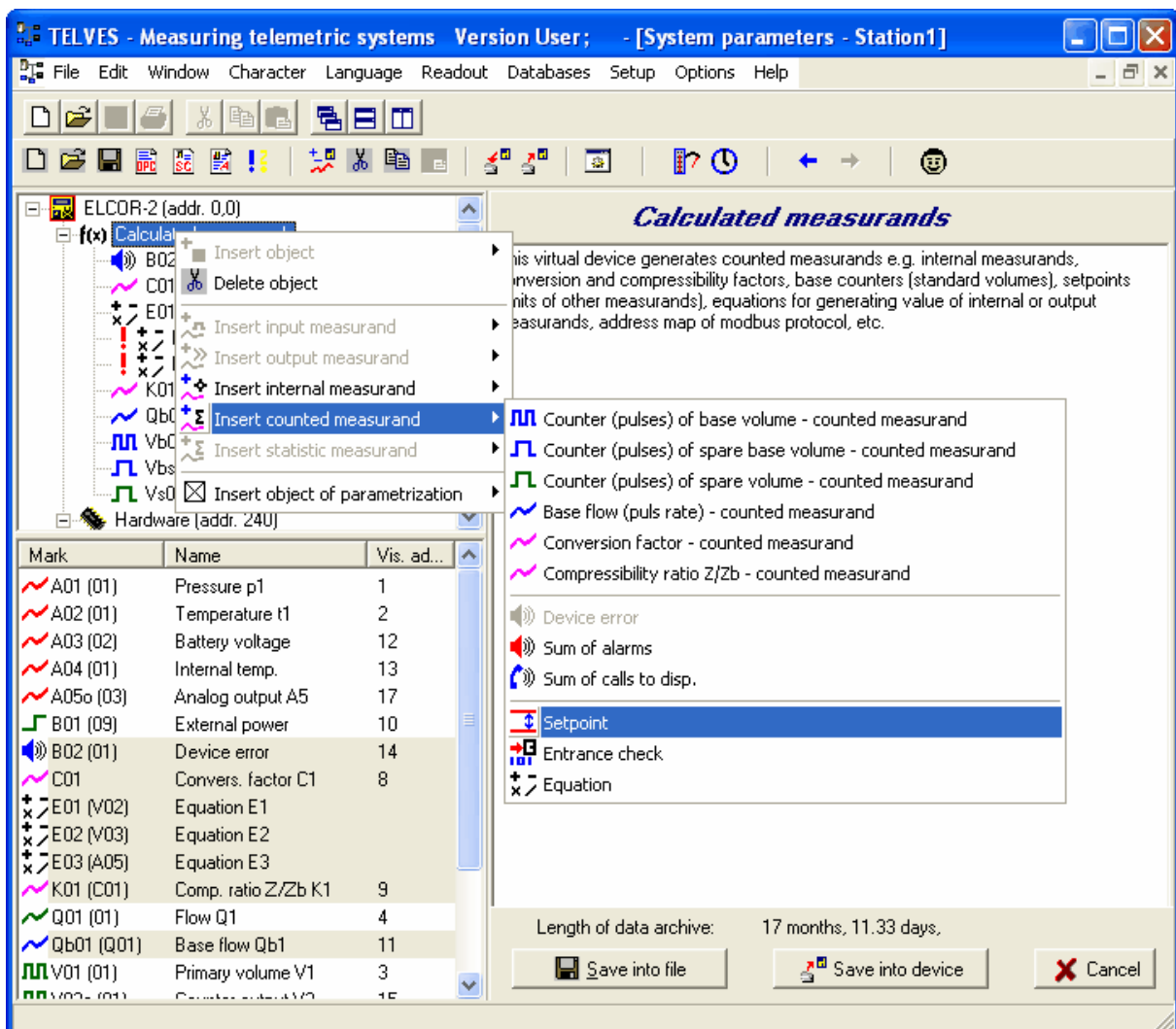

Fig. 58 Setpoint setting

Example:

If measured pressure p1 will pass over the value 120 (kPa) and this passing over will be longer than 5s, so then will be generated alarm (see Fig. 59).

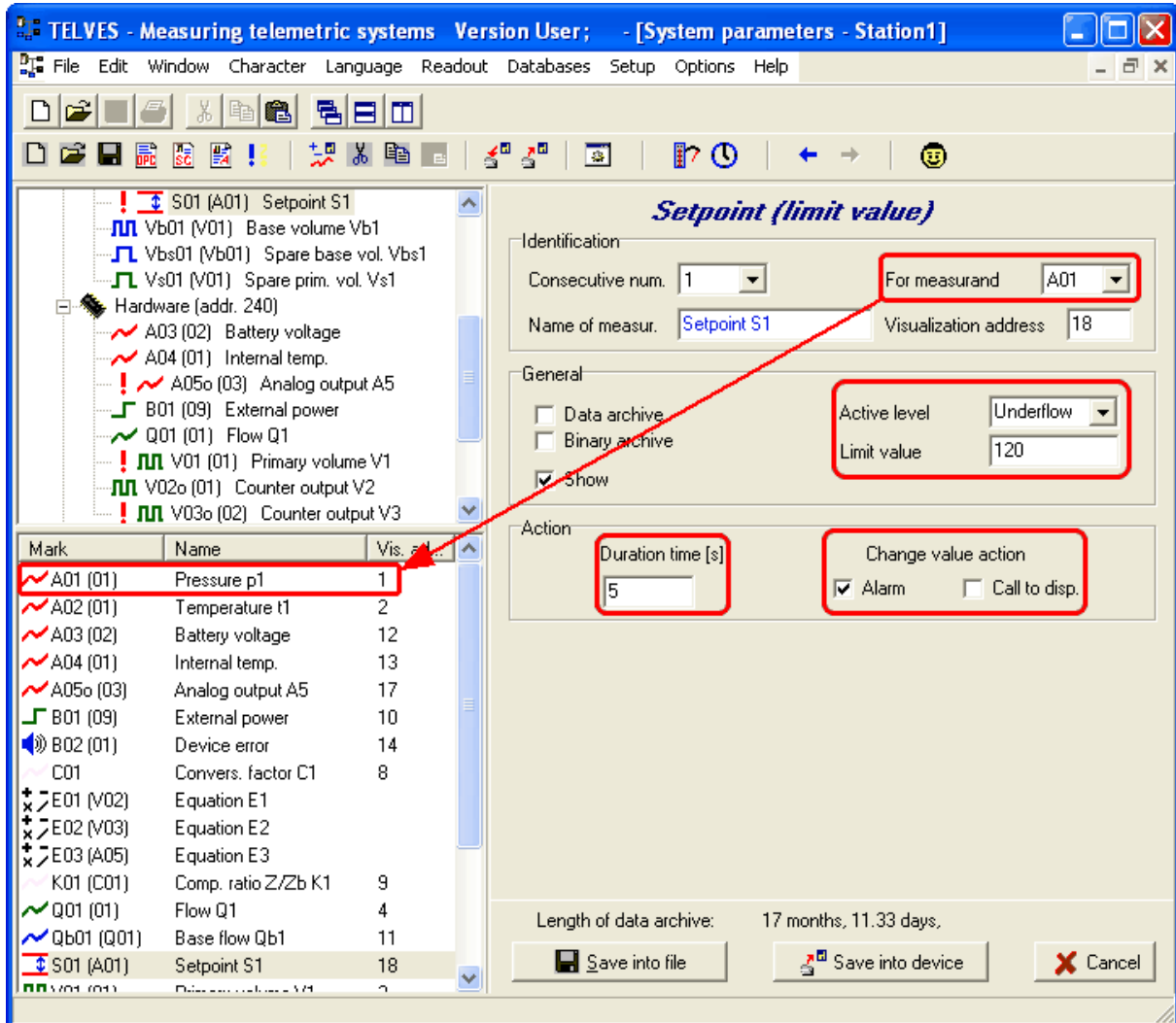

Fig. 59 Setpoint parametrization

15.6 Setting of external power supply failure

With help of following progress there is possible to watch the external power supply. Information about power supply condition may be saved into either data or binary archive, it is possible to initiate alarm signal or make a call on dispatching. Watching activation is made from item **Hardware** after pressing the right mouse button choose **Insert input measurand->External power** (see Fig. 60.)

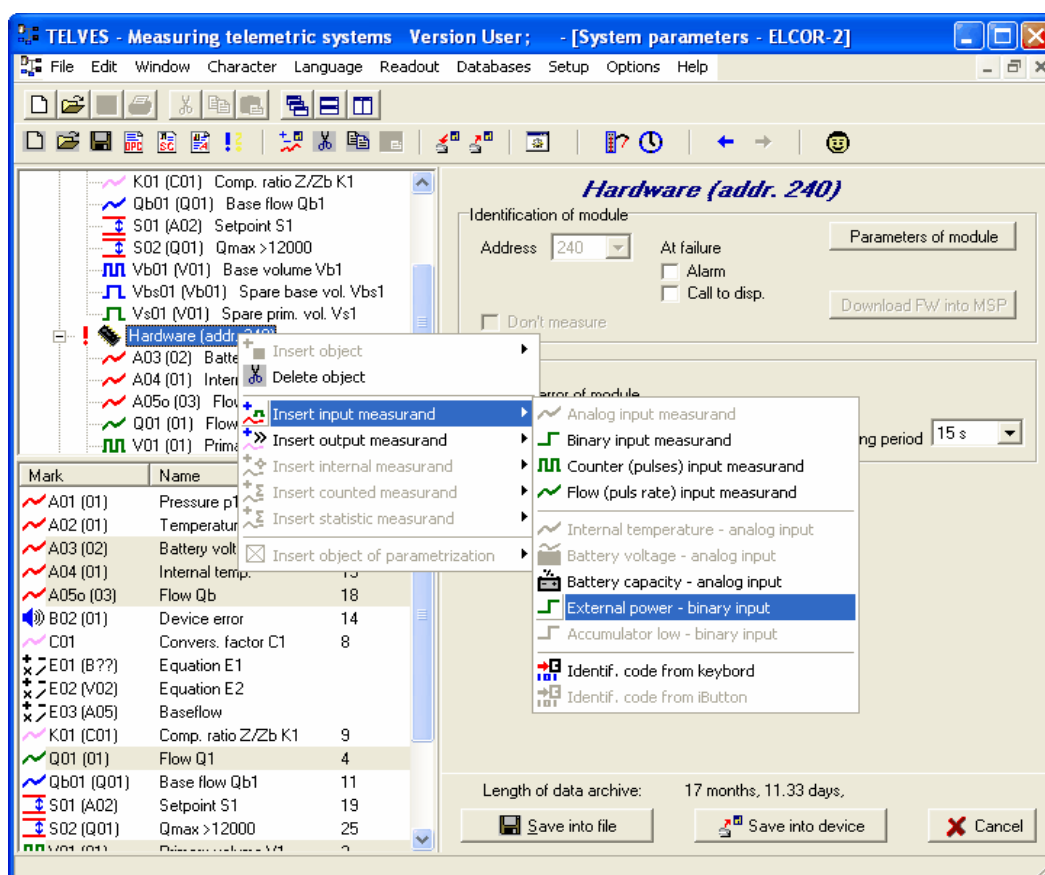

Fig. 60 Displaying of device external power supply

When will arise failure of external power supply (see Fig. 61) then will be generated alarm signal, but only in case that the failure will be longer then 3 s.

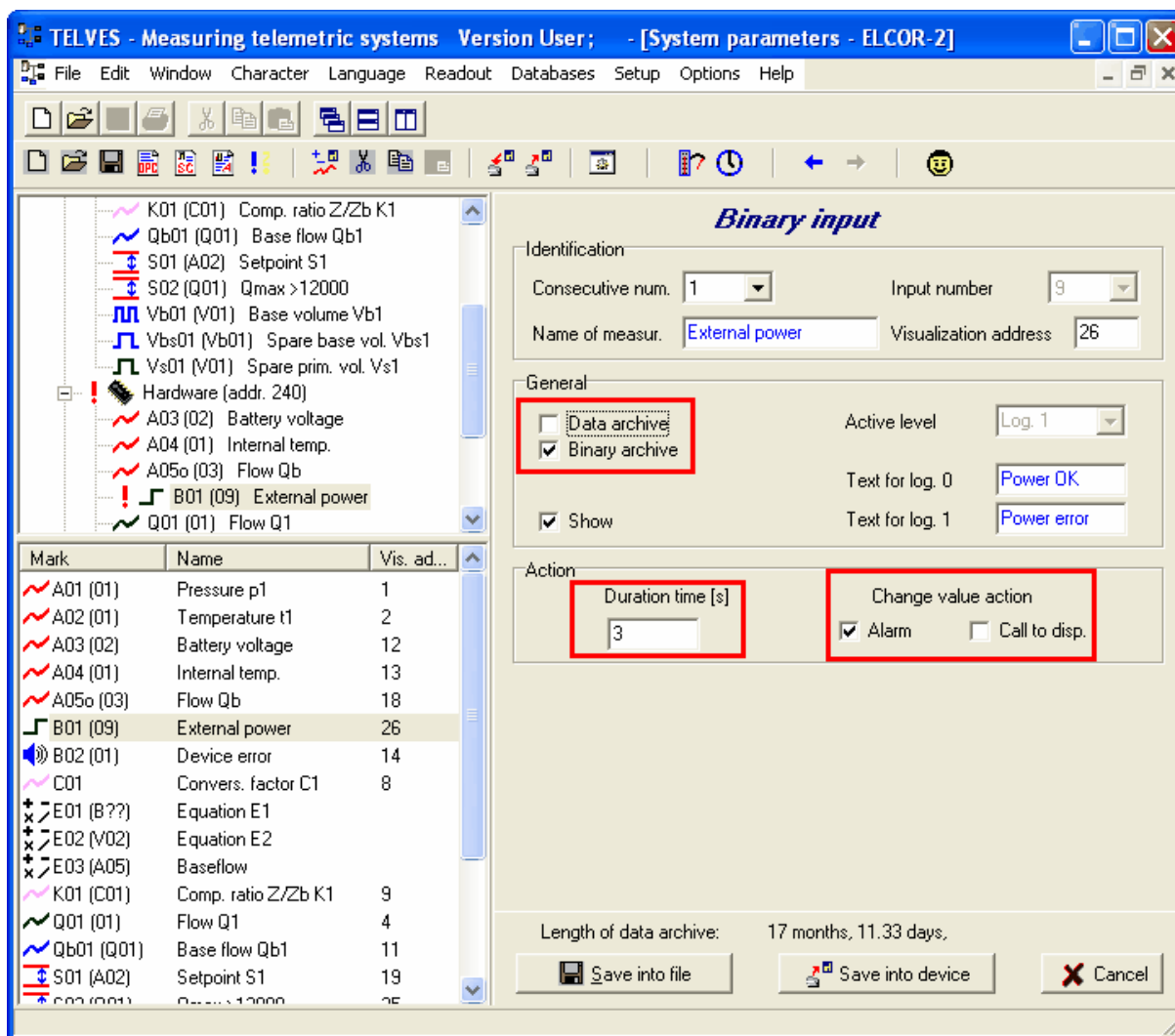

Fig. 61 Monitoring setting of external power supply failure

15.7 Setting of communication through MODBUS protocol

Standardly shipped devices are not configured for communication through MODBUS protocol. Here is progress for communication setting through this protocol. Initial conditions:

- MODBUS protocol may be set only in devices with firmware version 1.12 and higher
- Protocol MODBUS for reading of archived values is adjustable only in FW version 1.16 and higher.
- for setting of this communication is necessary to have prepared so-called MODBUS template (file with extension *.db, placed in subfolder Mobdus).

MODBUS template:

- it is pre-defined table of MODBUS addresses with sorted device parameters. In the there table are also information about type of the parameter – if it is

determined only for reading or also for writing. The manufacturer offers standard template for one-channelled or two-channelled device.

For device setting it is necessary to record this template into device.

As the first step of setting new object **Address map of MODBUS** is added into device parameters. The progress is displayed on the Fig. 62. Adding is made with click of right mouse-button on item **Calculated measurands->Insert object of parametrization**. Then there is displayed dialog window for file opening. Choose required MODBUS template (file with extension *.db).

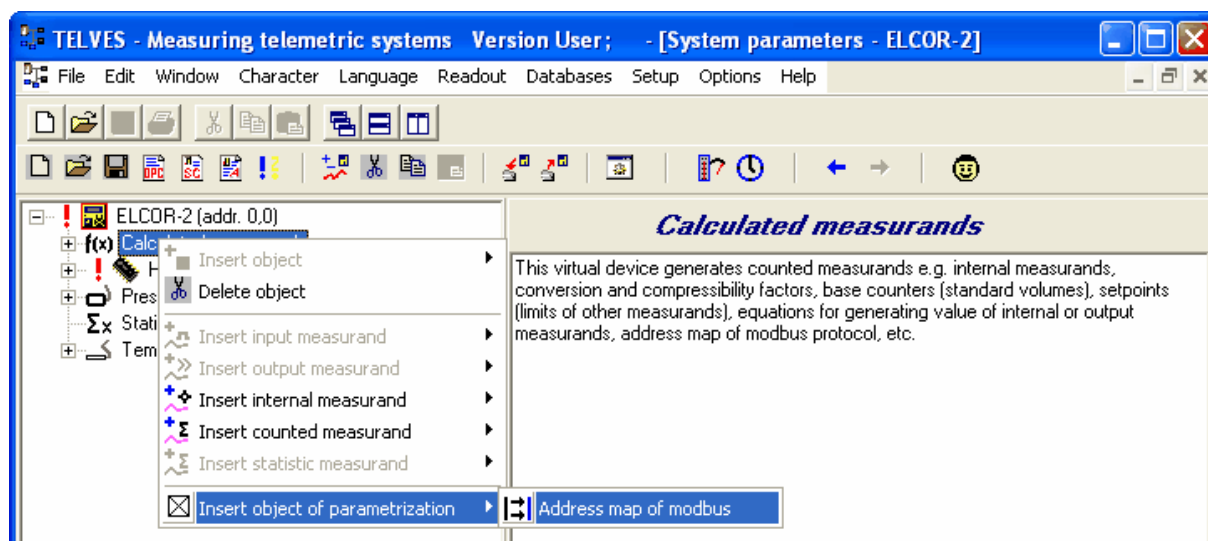

Fig. 62 MODBUS map inserting

After adding of MODBUS template file will be displayed in device parameters a new parameter **MODBUS map** (MM01 - Fig. 63). The list of parameters readable or writable via MODBUS protocol (from category either actual values or separate archives) is available at the right part of the screen. In case of any requirement for template changing it is necessary to change original template file. After this template must be the loaded again into MODBUS map with pressing the button Refresh from templ.

Note:

Only worker with access authorization of ASC (authorized service centre) is allowed to carry out this change.

15.7.1 Switching on communication through MODBUS protocol

In case of practical communication through MODBUS protocol is necessary to set this type of communication protocol on **System basic communication** on card **Communication** (Fig. 64).

After this device switching (after parameters into device writing) will be the communication interrupted (communication protocols on device and PC are different). For another communication with device is necessary to make in parameters setting for connection with consumption place switching on MODBUS protocol. It is also possible set parameter Adr1 either on non-zero address (which is set in the device) or on universal address **Adr1 = 248** (see 14.3.1).

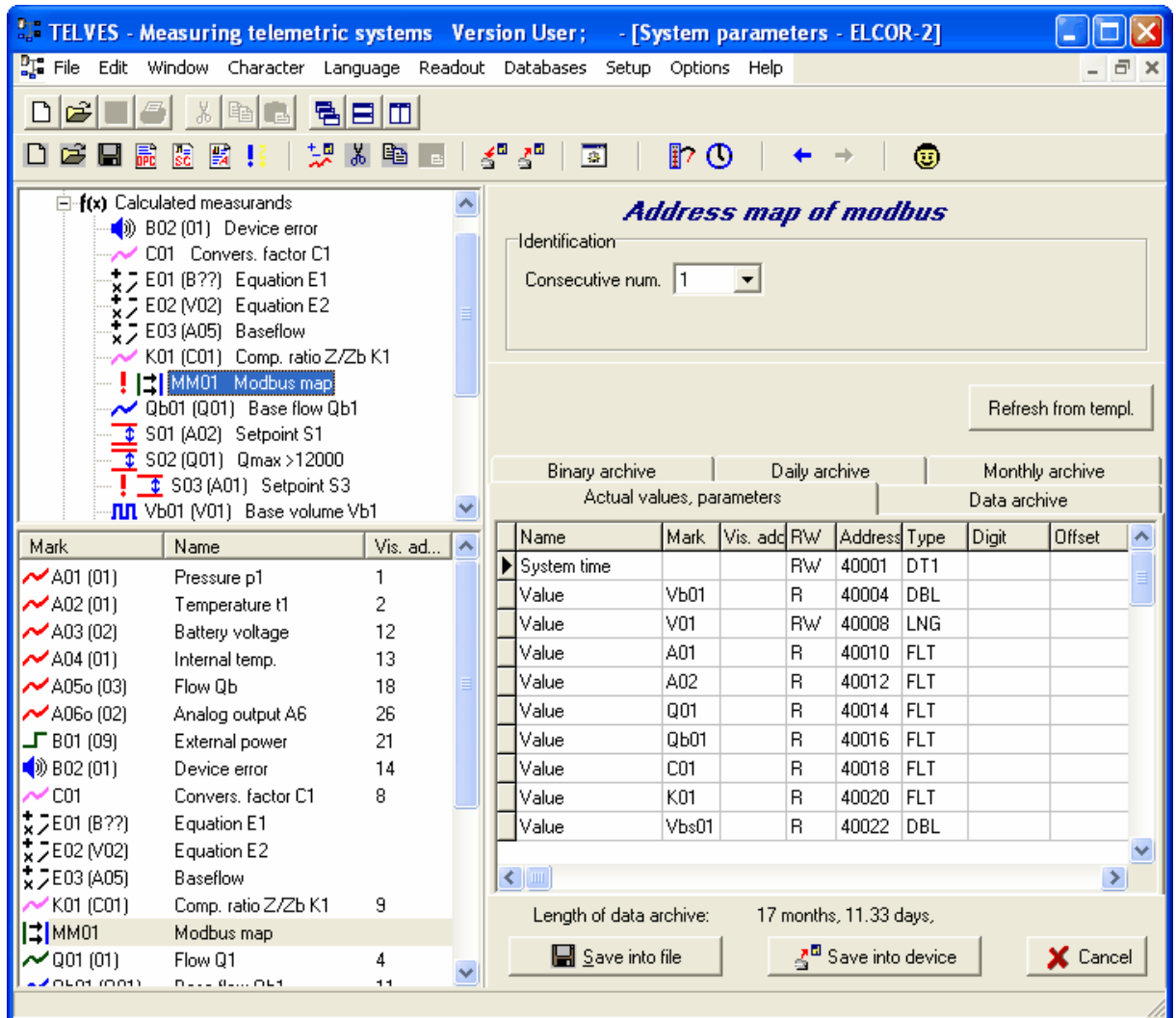

Fig. 63 Parameter of MODBUS map address

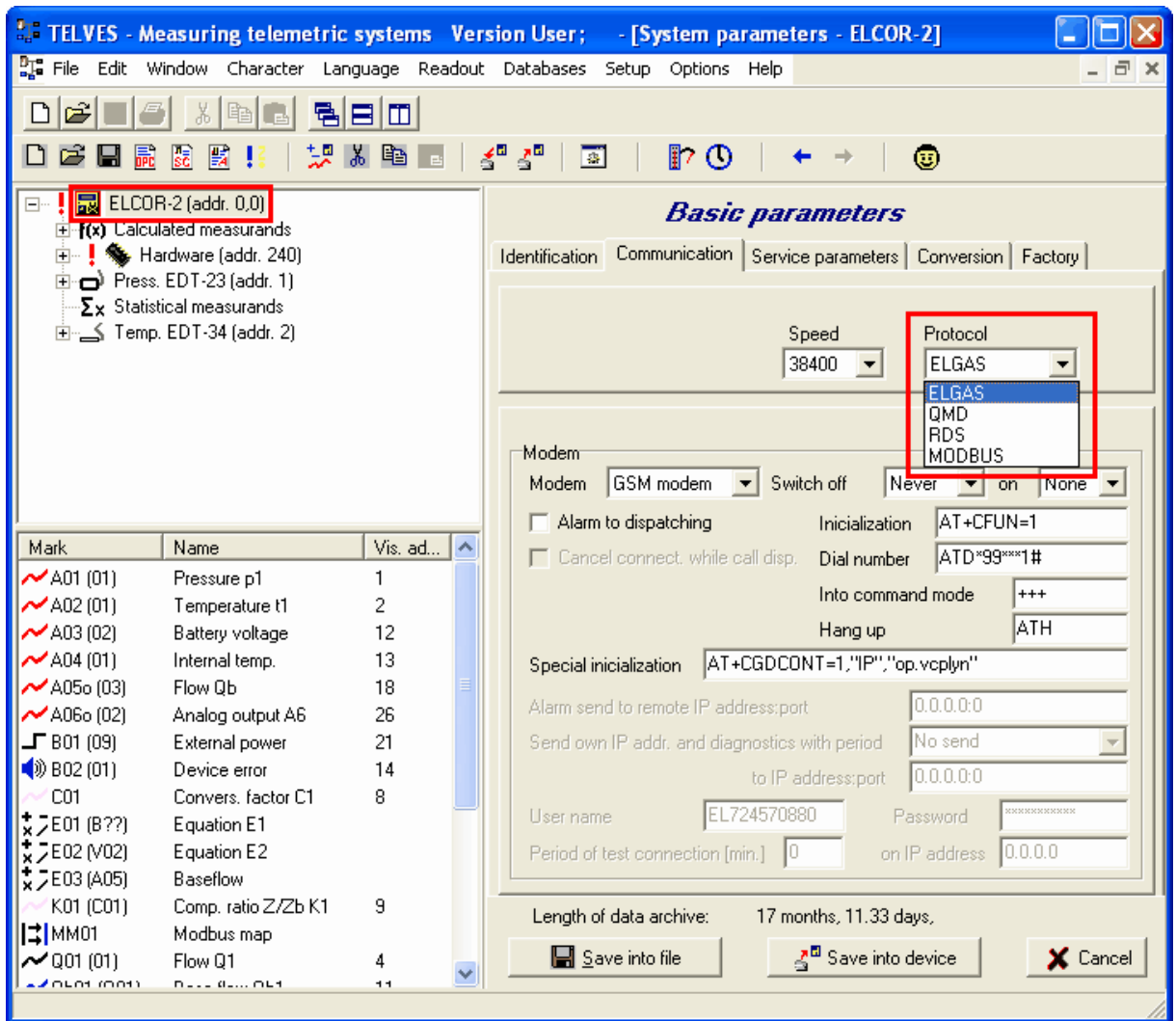

Fig. 64 Switch of communication protocol in the device

16 Pressure and temperature sensor/transducer replacement

Replacement of both sensors is very simple. Exchange consists from mechanical mounting of sensor/transducer into the device followed by loading of file with calibration data by the help of supplied service software. In case of temperature sensor are calibration data delivered separately (e.g. on CD). Pressure transducer has calibration data stored in his own memory so it is not necessary to load calibration file apart.

Warning:

In case of replacement of sensor/transducer which is measuring basic quantity, it is a hit to metrological part of device. Before this operation it is necessary to breach metrological seal and move metrological switch to ON position.

Breaching of metrological seal means, that initial verification is not valid!

This operation can be proceed only by employee with rights of accredited service center (ASC). To proceed this operation it is necessary to switch metrological switch into the ON position and also it is important to use hardware key (key variant: Authorized service center).

16.1 Pressure and temperature sensor/transducer replacement procedure in miniELCOR device

- Disconnect device from power supply – disconnect external power supply (if applied) and remove main battery (existing device settings and also data in archives will not be lost)
- Disconnect required sensor/transducer from the device
- Apply new sensor/transducer into the device
- Reconnect power feeding to device – battery first and secondly external power supply (if applied)
- Switch metrological switch to ON position (necessary to breach metrological seal)
- By the help of service software proceed software settings of device for proper communication with the new sensor/transducer (see chapter 16.2 and 16.3)
- Switch metrological switch to OFF position.
- Proceed new verification with new sensor/transducer

16.2 Software settings of device for proper communication with new temperature sensor

At this moment we have replaced temperature sensor with the new one, battery is inserted back into device and now it is necessary to finish installation by the help of service software.

Readout parameters from the device (menu **Readout-> parameters**). In next step click in menu of parameters on „**Hardware**“ item (see Fig. 65).

In right part of the opened window click on item „**Change temperature transmitter**“. In next window enter path to the data file *.txt with stored calibration data, which was delivered together with temperature sensor (see Fig. 66). Select and confirm by clicking on „**Open**“ button required calibration file. Calibration data are stored in parameters now. You should see following window after loading of calibration file (see Fig. 67).

To finish this operation save parameters into the device by clicking on „**Save into device**“ button. After saving of parameters readout parameters from the device in order to check if all changes were proceed succesfully. Click on „**Hardware**“ item (see description above) and check corectness of serial number placed on sensor cable with serial number in parameters (see Fig. 68).

If serial numbers are complying, changing of sensor is sucessfully finished. In case that serial numbers are varying, check correctness of your steps during changing of sensor, step by step, or check if was used correct calibration file.

Note: After replacement of temperature sensor it is possible (if needed) to make one or two point calibration of sensor. (see Fig. 67).

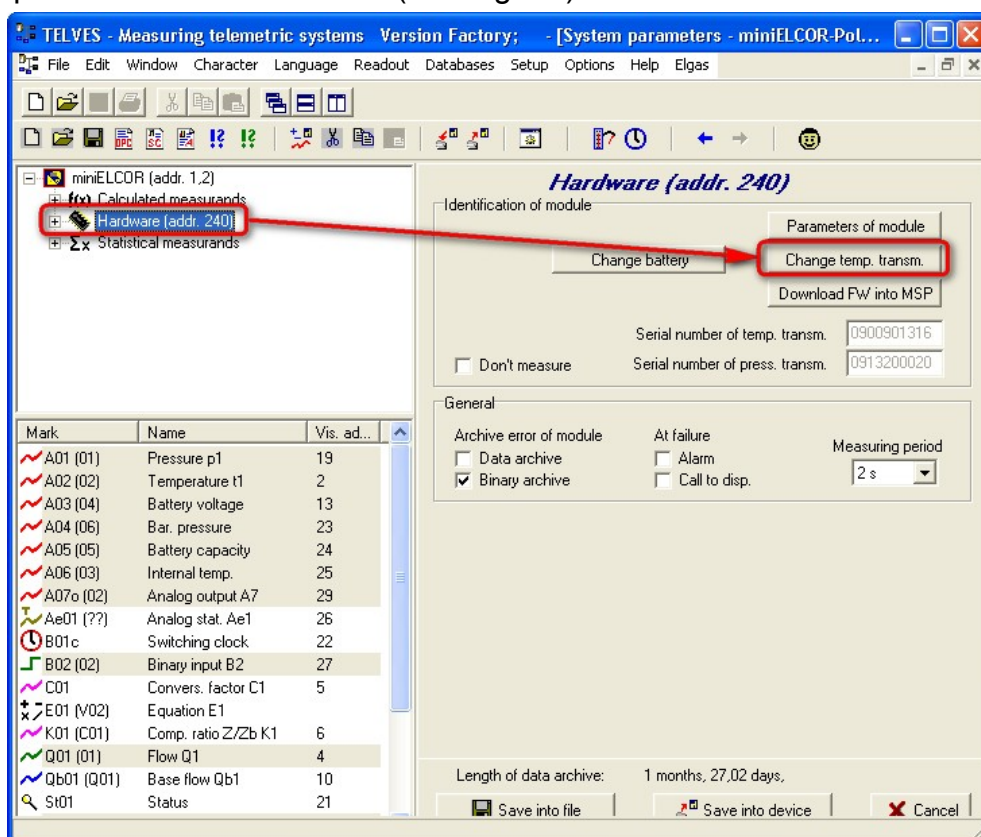

Fig. 65

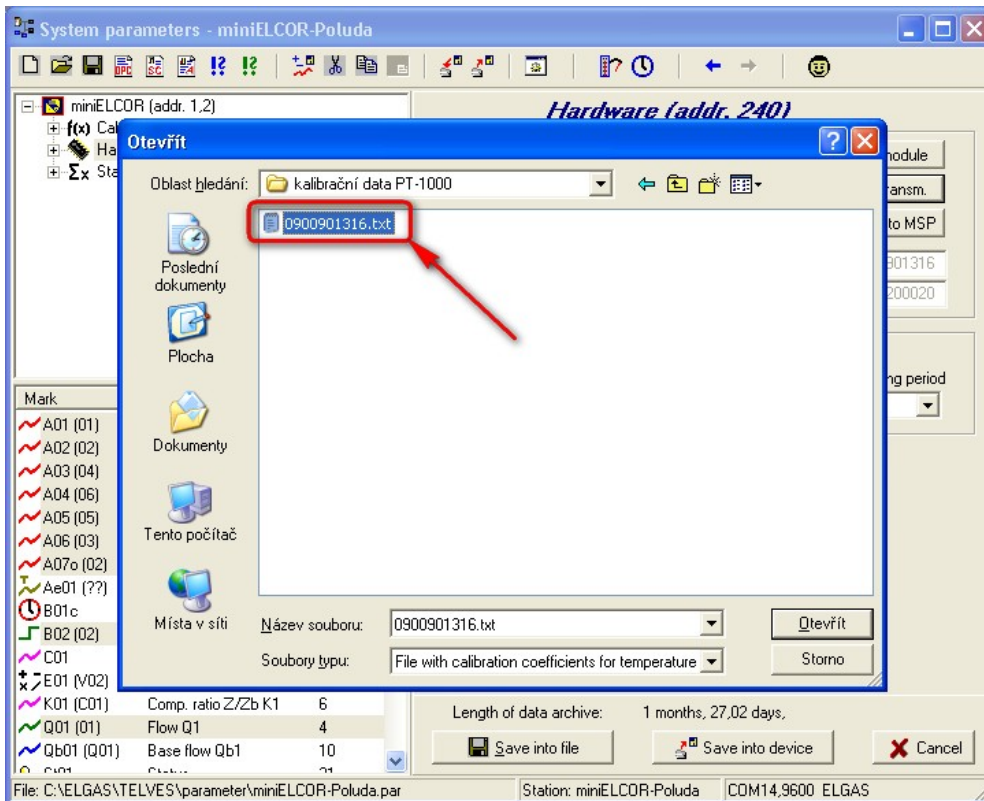

Fig. 66

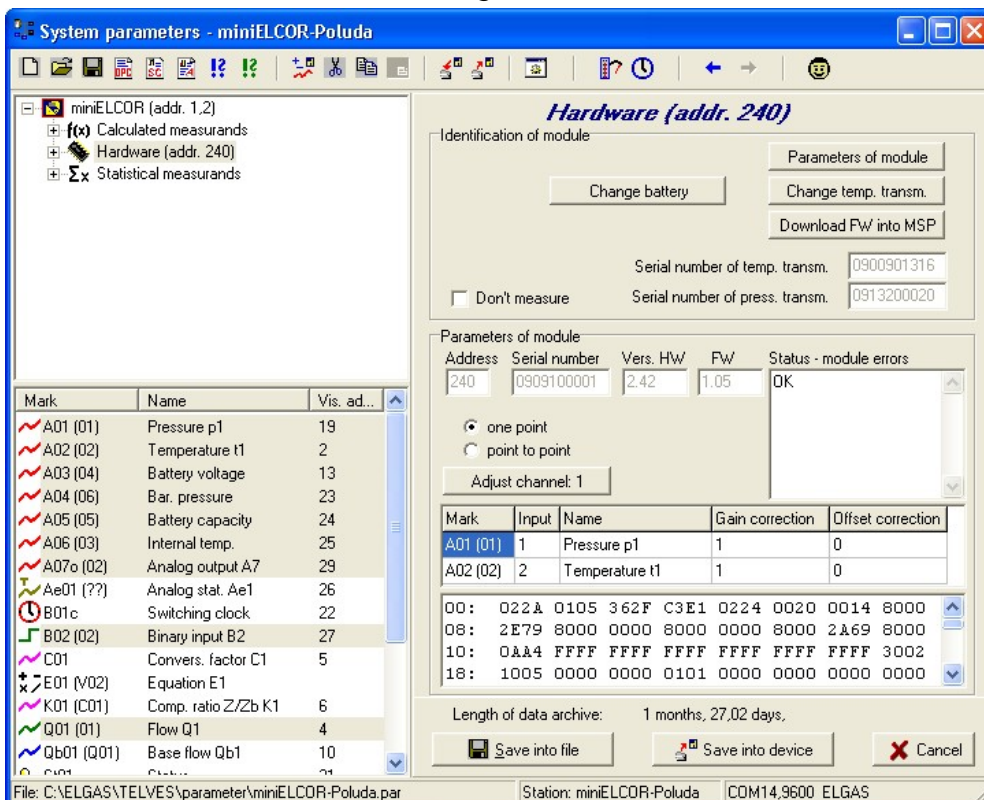

Fig. 67

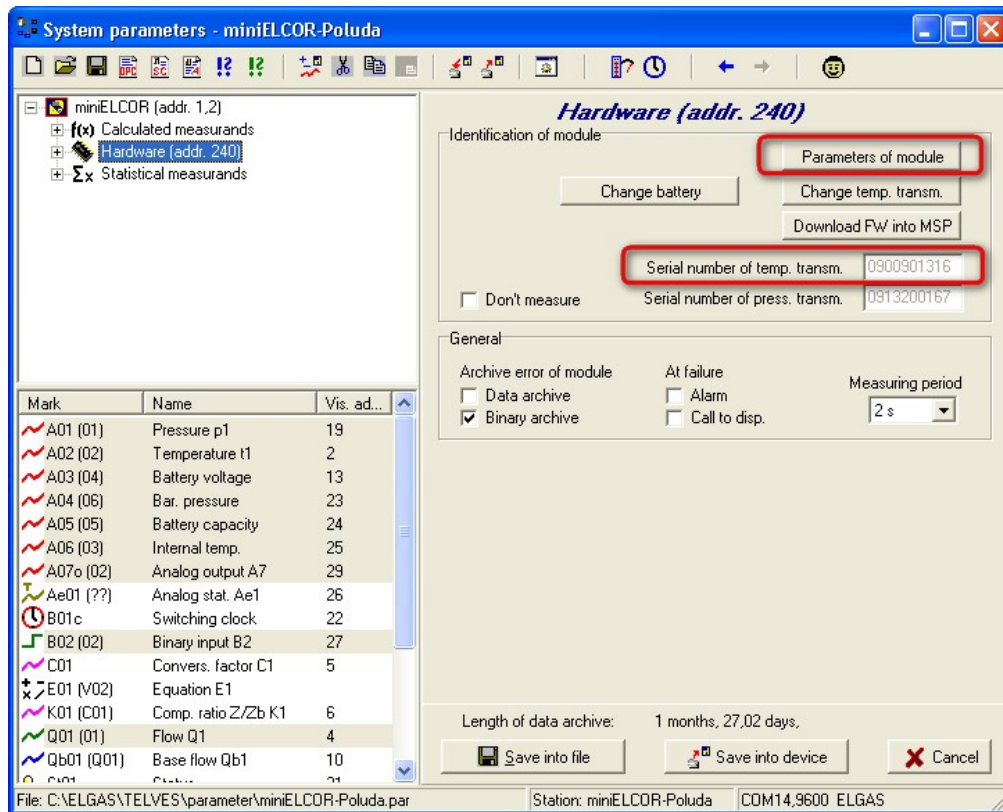

Fig. 68

16.3 Software settings of device for proper communication with new pressure transducer

At this moment we have replaced pressure transducer with the new one, battery is inserted back into device and now it is necessary to finish installation by the help of service software.

Readout parameters from the device (menu **Readout-> parameters**). In next step click in menu of parameters on „**Hardware**“ item (see Fig. 65). In right side of the window click now on „**Parameters of module**“ (see Fig. 68). Now the service software will load calibration data from the transducer's memory into parameters of the device. At this time is software setting almost finished. Now it is necessary to save parameters into the device by clicking on „**Save into device**“ button. After that check compliance of serial number placed on transducer and in parameters.

Hereby is the transducer replacement finished.

Note: After replacement of pressure transducer it is possible (if needed) to make one or two point calibration of the pressure sensor. (see Fig. 67).

17 Software settings of the device for proper communication with external digital temperature (EDT-34) or pressure transducer (EDT-23)

Chapter 5.3 describes how to extend device with pressure or temperature digital transducer. Following software setting suppose already installed expansion module RS-485 and also already connected digital transducer (EDT-34 or EDT-23).

Now we will describe how to add new digital transducer into software parameters.

17.1 Adding of digital transducer into device's parameters

As a first step it is necessary to readout parameters from the device (menu **Readout ->Parameters**).

Now click in parameters menu on „**miniElcor**“ item. Using right mouse button open menu. In opened menu select „**Insert object**“ and in next selection choose required transducer (e.g. temperature transducer EDT-34, see Fig. 69). Herewith we have added digital transducer into parameters and now it is necessary to save modified parameters into the device by clicking on „**Save into device**“ button.

Now click in parameters menu on just added digital transducer EDT-34 (see Fig. 70). Because it is a digital transducer connected to intrinsically safe serial interface RS-485 such device must have assigned communication address. There can come two possibilities in context of assigning of communication address:

- a) New digital transducer has the same address as is predefined in parameters – standarty it is address no. 1 (see chapter 17.1.1.).
- b) New digital transducer has different address than is stored in device's parameters (see chapter 17.1.2).

17.1.1 Newly installed digital transducer has the same address as is predefined in device's parameters (standarty address no.1)

In this case it is not necessary to change communication address. By clicking on „**Parameters of module**“ button (see Fig. 71) we will check if transducer is communicating with the device. If everything is correct, window with transducer's parameters will appear (see Fig. 71). If service software will warn you, that „**Module doesn't respond**“ it means that the address of transducer is different from address preset in parameters and it is required to set correct address. Setting of the correct communication address will be described in chapter 17.1.2 .

If transducer communicate without any problem (parameters of the module were readed correctly), installation is finished.

Note: After adding of digital transducer it is possible (if needed) to make one or two point calibration of transducer. (see Fig. 72).

17.1.2 Newly installed digital transducer has different address from address preset in device's parameters

If we will find that transducer is not communicating, probably has a different communication address than is preset in device's parameters. To set correct address click in device's parameters on transducer item (in our case „**Temperature EDT-34**“ see Fig. 70). After that in right part of the window click on „**New address**“ button. Service software will ask you to enter serial number of added transducer. Enter serial number and click „**OK**“ (see Fig. 73). After that service software will ask you to enter new communication address. Enter the same address which is stored in device's parameters – standardly it is the address no.1 (see Fig. 74). New address is stored in transducer now.

By clicking on „**Parameters of module**“ button we will check if transducer is communicating properly with the device. If everything is correct you will see window with transducer's parameter (see Fig. 71). Herewith we finished the change of address and also installation of transducer is finished.

Note: After adding of digital transducer it is possible (if needed) to make one or two point calibration of transducer. (see Fig. 72).

17.2 Adding of quantity measured by digital transducer into device's archives

After addition of digital transducer into device's parameters it is also necessary to add quantity (temperature in our case) measured by this transducer into archives. If we will not add this quantity as a new item into archives this information will be shown only in actual values.

In device's parameters click on quantity which is measured by digital transducer (see Fig. 76). In right part of the window tick-on archives where you want to have stored this quantity. In the end save this change into device by clicking on „**Save into device**“ button.

18 Final verification of the device after replacement of sensor/transducer or adding of digital transducer

As a final step is recommended to proceed verification of the device by the help of selfdiagnostic function. Click on „**MENU- Setup/Status (diagnostics) of device/from Device**“. New window will be opened which describes actual status of device (see Fig. 75). In the column „**State of last test**“ must not be any warning or error! If device announce warning or error, click on „**Devicee test**“ button. In case that the problem continues, contact manufacturer’s technical support.

If everything is all right and still warning or error message is displayed in „**Summary status**“ column, click on „**Clear summ. Status**“ thereby all historical warnings and errors ocured before replacement or adding of transducer will be cleared.

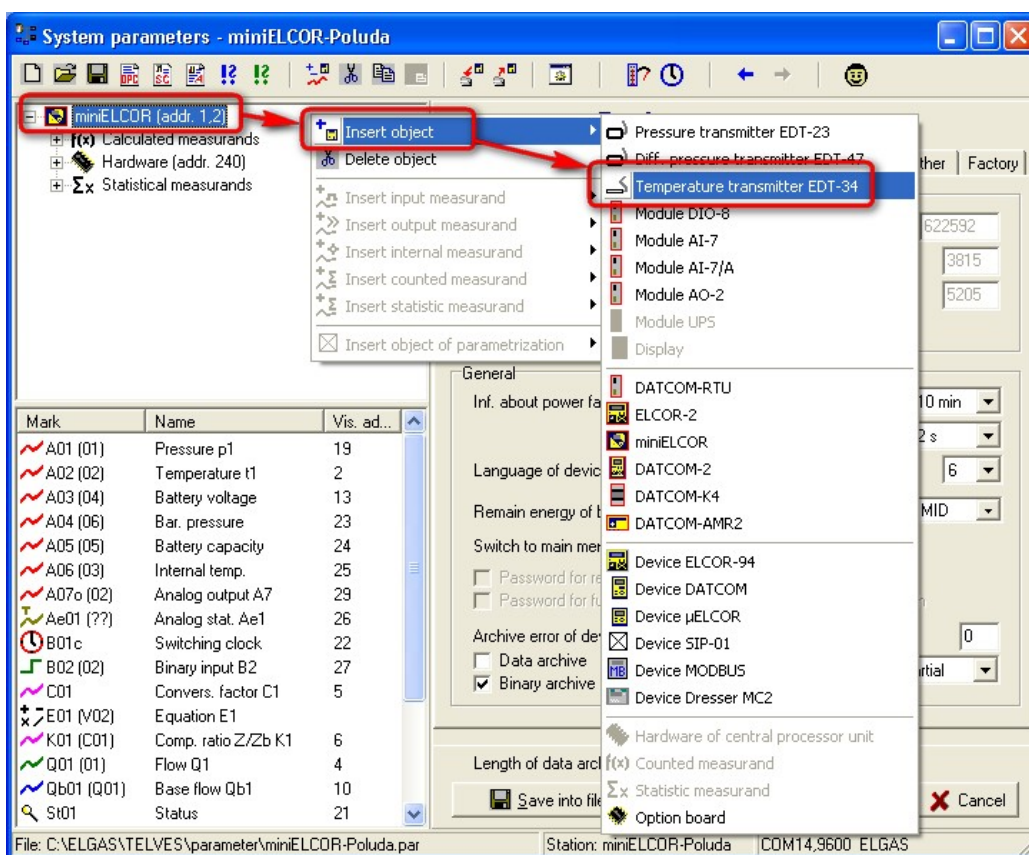

Fig. 69

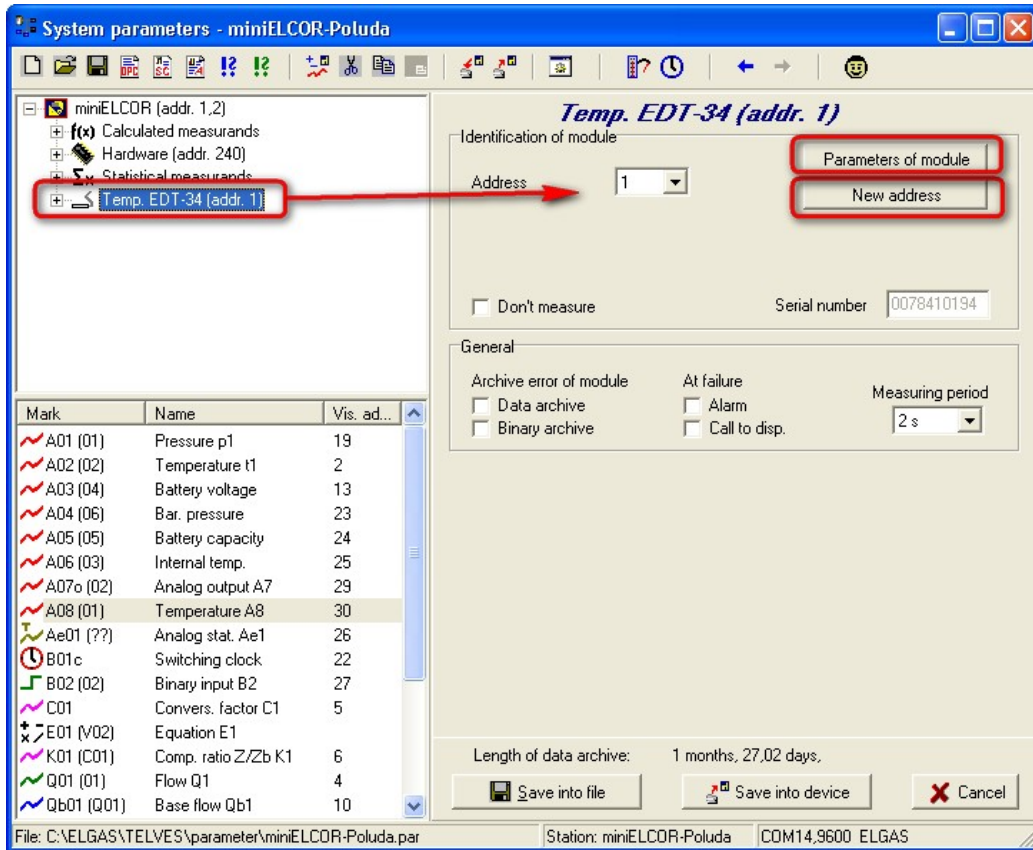

Fig. 70

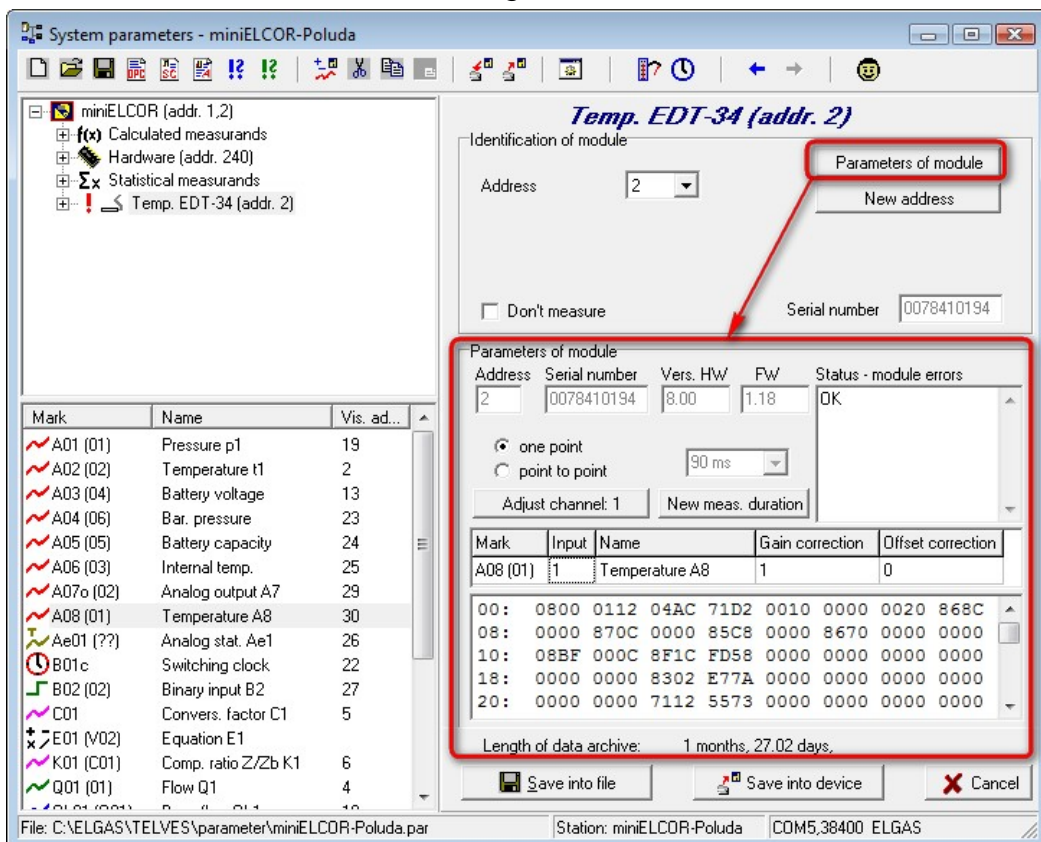

Fig. 71

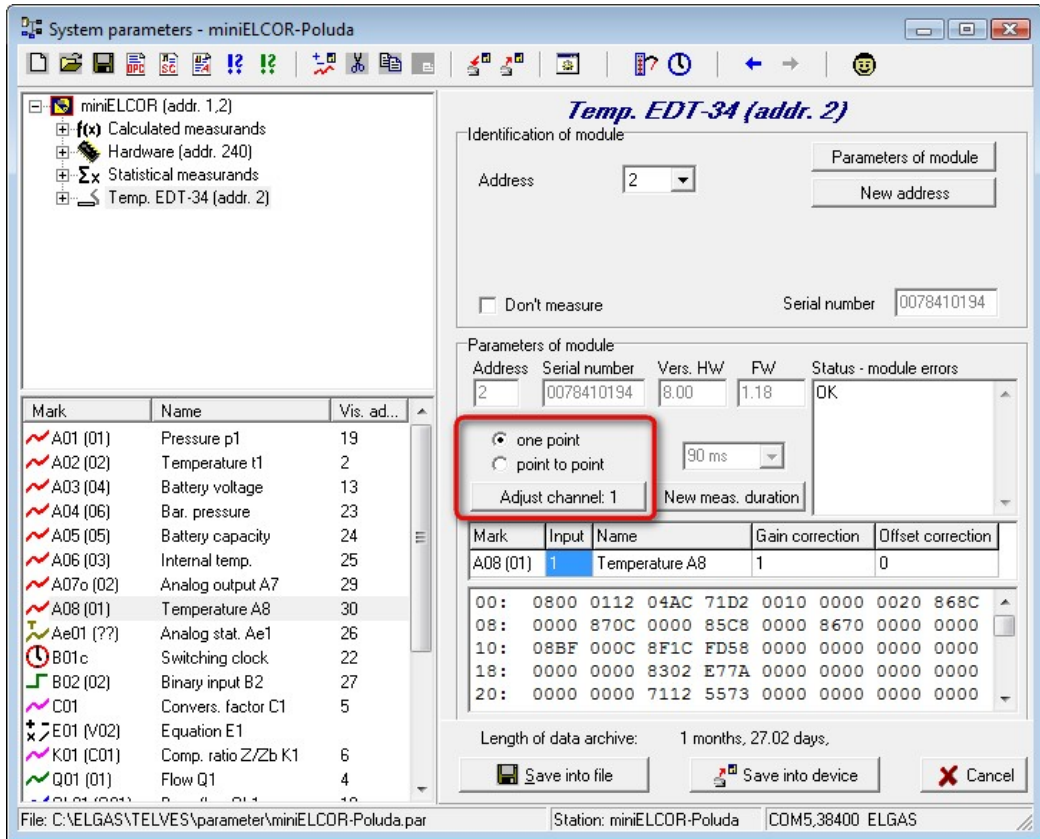

Fig. 72

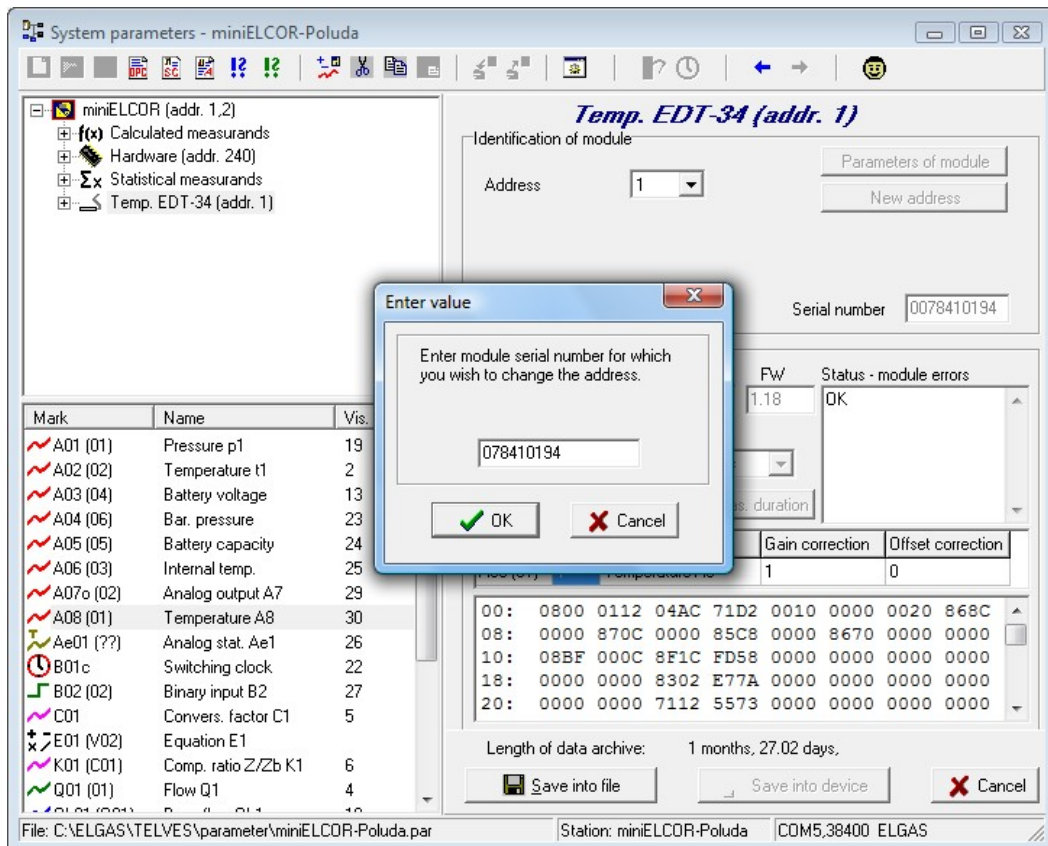

Fig. 73

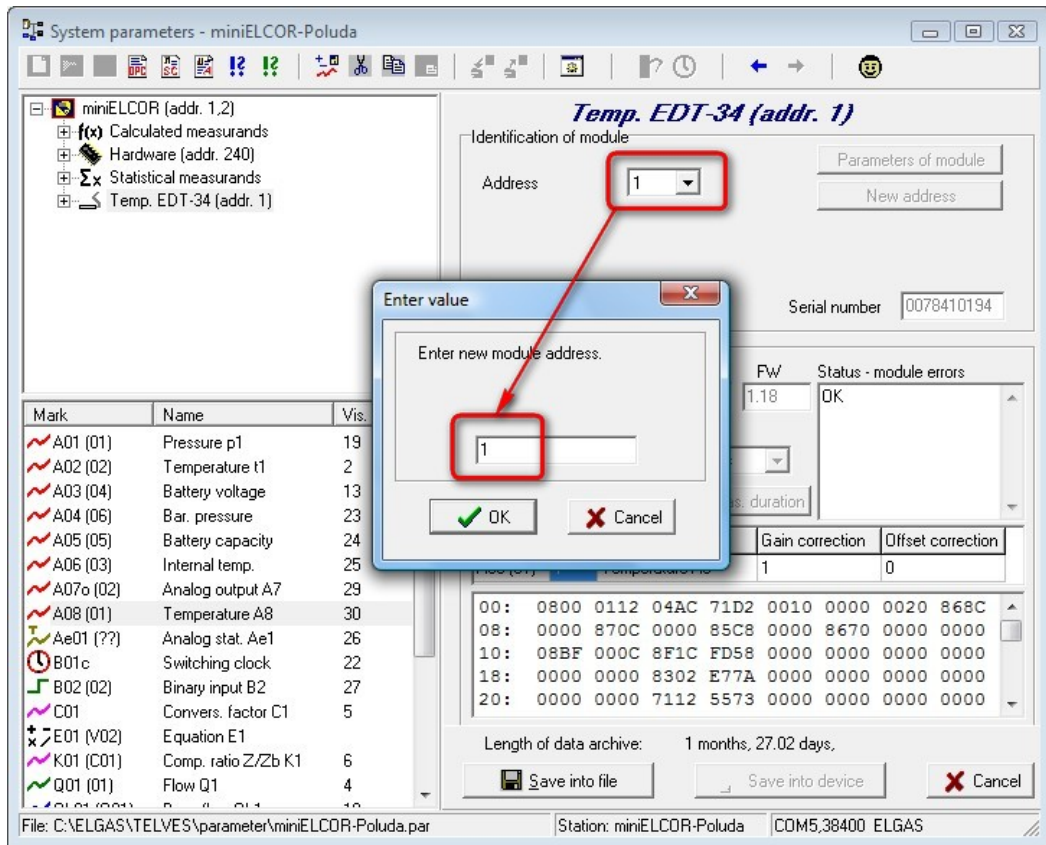

Fig. 74

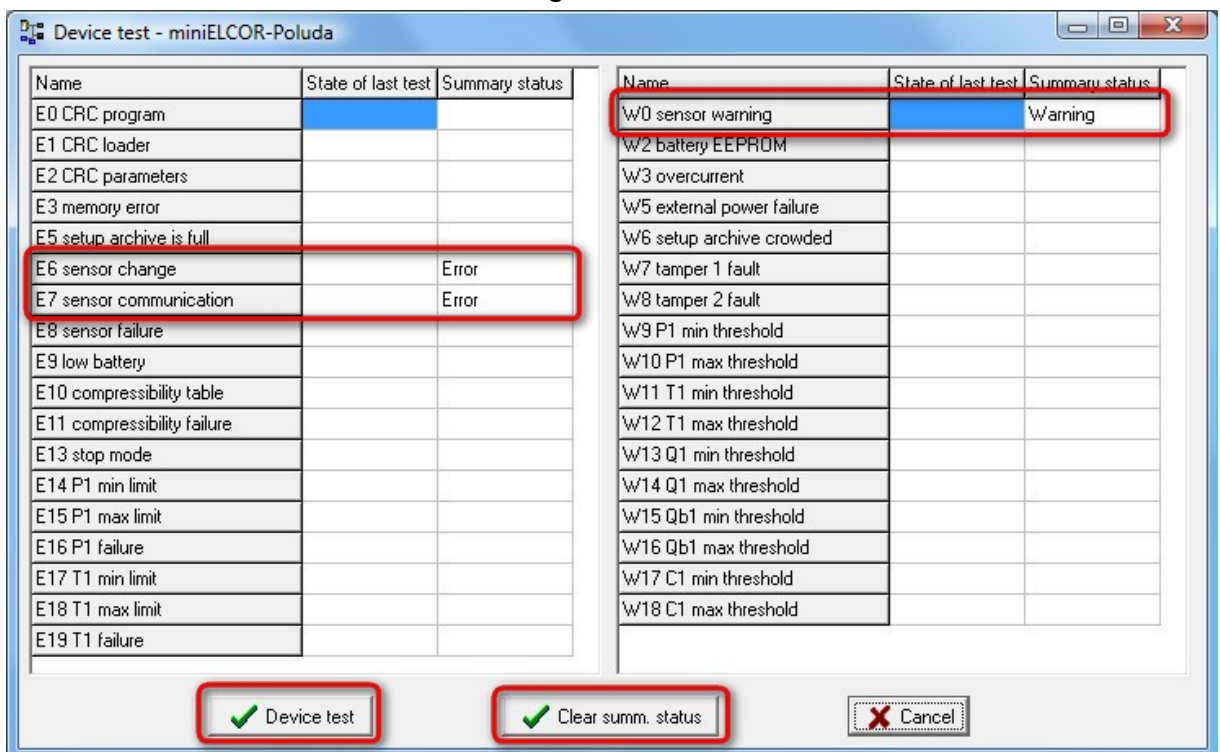

Fig. 75

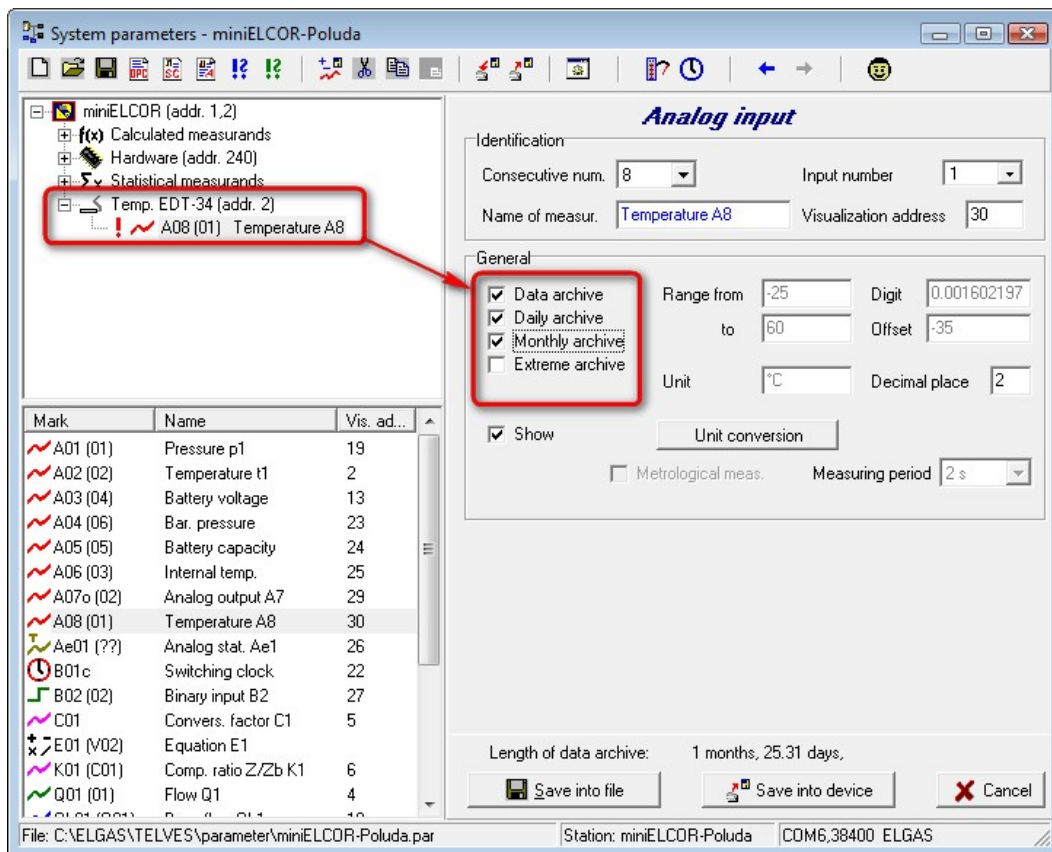

Fig. 76

19 What to do if something does not work

<i>problem</i>	<i>Possible cause</i>
Readout does not working	Set wrong PC port. Set different address 1 or address 2 in the device and in the PC. Set different communication speed between PC and device. Set different communication protocol between PC and device.
Impossible to set parameters	Service switch in OFF position. Wrong password (only if is in the device set password for full access). Full setting archive – send the device into authorized service centre.
Wrong value of primary volume	Check connection between device and gas meter (pulse input). Wrong set of gas meter constant. Wrong set of initial state of primary volume – set value of primary volume with momentary volume on gas meter.
Illogical value of standard volume	The device saved into error values because of wrong values saved in archives – start device diagnostics.
Impossible to switch on the display	Discharged battery. Exchange battery or connect external power supply.
Device communicates but it does not measure	STOP MOD – discharged battery. Exchange battery or connect external power supply.
Wrong number of output pulses	Wrong setting of output pulses constant or delay between pulses according to frequency of input pulses.
Battery discharges very quickly	Factors which affects battery consumption: <ul style="list-style-type: none"> ▪ Too frequent communication – Extend communication interval ▪ Short measuring period– Extend measuring period ▪ Output pulses generating – cancelled output pulses ▪ Switched on HF input– switch off with help of service SW.
On display is Err or Wrn	Start TEST from device keyboard.

If corrector indicates errors and warning message (on first page is shown attribute **Err** or **Wrn**) there is necessary to start internal device test and consequently either via keypad or via computer to identify type of error. This procedure is described in chapter 9.9 and 14.3.7.

In following table there is described list of possible errors nad warnings messages and possible solution.

<i>Visual display</i>	<i>Error description and pertinent solution</i>	<i>Abbrev.</i>
E0 CRC of program	Error of check sum in FW - Necessary repair in ASS	Err
E1 CRC of loader	Error of checksum of loader. - Failure of memory FLASH, Necessary repair in ASS	Err
E2 CRC of parameter	Error of checksum of device parameters. - Accomplish changes of any parameters and write change into device.	Err
E3 memory error	Error of device memory. - Necessary repair in ASS .	Err

E4 error of FLASH	Error of device FLASH memory. - Necessary repair in ASS	Err
E5 full setup archive	Full setup archive. - Device is full operational but no parameters are changable. Erase setup archive in ASS.	Err
E6 transducer replacement	Accomplished replacement of transducer or modification of parameters. - Set back device to original setup or arrange verification in ASS.	Err
E7 transducer communication	Error in communication with transducers. - Check connection of transducers for example setup of correct communication address.	Err
E8 transducer error	Error of transducer. - Measured value can be out of measured range, or transducer is defective – necessary replace transducer in ASS.	Err
E9 battery voltage	Battery voltage decreased under allowable level. - Replace battery.	Err
E10 compressibility table	Error of calculation in compressibility table due to input parameters. - Correct gas composition	Err
E11 compressib.	Infeasible calculation of compressibility table due to range restriction of used standard	Err

<i>Visual display</i>	<i>Error description and pertinent solution</i>	<i>Abbrev.</i>
W0 transducer warning	Warning message from transducer , no influence on metrological properties.	Wrn
W1 battery capacity	Capacity of battery decreased under allowable level (SW calculation) Warning message 90 days before discharged.	Wrn
W2	- unused -	Wrn
W3 surge current terminal	Current overload appears on internal bus terminals .	Wrn
W4	- unused -	Wrn
W5 external power shortage	External power shortage. During external power shortage internal power is ensured by battery. But in case of HF Namur sensor usage no signals from sensor is registered during external power shortage.	Wrn
W6 surge current of device	Current overload in device appears.	Wrn

Note:

ASS – authorized service centre

20 Literature

- [1] 22/1997 Coll. Act on Technical Requirements for Products and on Amendments to Some Acts
- [2] EN 60079-0:2006 – Electrical apparatus for explosive gas atmospheres – Part 0: General requirements.
- [3] EN 60079-11:2007 – Explosive atmospheres –Part 11: Equipment protection by intrinsic safety “i”
- [4] EN 60079-26 :2007 – Explosive atmospheres – Part 26: Equipment with equipment protection level (EPL) Ga
- [5] EN 12405-1:2006 – Gas meters – Conversion devices – Part 1: Volume conversion
- [6] EN 60079-14:2004 – Electrical apparatus for explosive gas atmospheres – Part 14: Electrical installation in hazardous areas (other than mines).
- [7] EN 61000-4-2:1995+A1:1998+A2:2001 – Electromagnetic compatibility (EMC) - Part 4: Testing and measurement techniques – Section 2: Electrostatic discharge immunity test – Basic EMC Publication
- [8] EN 61000-4-3:2006/A1:2008 Electromagnetic compatibility (EMC) – Part 4-3: Testing and measurement techniques – Radiated, radio-frequency electromagnetic field immunity test.
- [9] EN 61000-4-4:2004 - Electromagnetic compatibility (EMC) – Part 4-4: Testing and measurement techniques – Electrical fast transient/burst immunity test.
- [10] EN 61000-4-6:2007+Cor.:2008 – Electromagnetic compatibility (EMC) - Part 4: Testing and measurements techniques – Section 6: Immunity to conducted disturbances, inducted by radio-frequency fields.
- [11] EN 61000-6-2: 2005/Cor.:2005-09 - Electromagnetic compatibility (EMC) – Part 6-2: Generic standards – Immunity for industrial environments.
- [12] EN 61000-6-4: 2007
- [13] EN 62056-21:2002 Electricity metering - Data exchange for meter reading, tariff and load control – Part 21:Direct local data exchange.
- [14] IEC 60364-4-41: 2005 – Low voltage electrical installations – Part 4-41: Protection for safety - Protection against electric shock.
- [15] Modicon Modbus Protocol Reference Guide, Modicon Inc., Industrial Automation Systems, 1996
- [16] FTZÚ 08 ATEX 0324X – EC -Type Examination Certificate
- [17] EN ISO 12213-3: 2009 - Natural gas – Calculation of compression factor – Part 3: Calculation using physical properties
- [18] Directive 2006/66/EC of the European Parliament and of the Council on batteries and accumulators and waste batteries and accumulators

21 Relevant Literature

- [19] TELVES – Software description.. User manual. Elgas, s.r.o.
- [20] EDT 23 – Pressure converter with Modus protocol. User manual. Elgas, s.r.o.
- [21] EDT 34 – Temperature converter with Modus protocol. User manual. Elgas, s.r.o.

22 Software

[22] TELVES exe, Elgas, s.r.o., software supplied with device

[23] Reliance, GEOVAP Pardubice

23 Used trade marks

{1} IrDA[®] - is a trade mark of Infrared Data Association

{2} ModBus[®] - is a trade mark of Modicon

24 List of figures

Fig. 1 Volume and energy calculations - Scheme.....	6
Fig. 2 Device dimensions.....	7
Fig. 3 Main parts of the device.....	8
Fig. 4 Examples of external power supply	11
Fig. 5 Security marks (device without SCR encoder)	12
Fig. 6 Security marks of miniELCOR SCR.....	12
Fig. 7 Product label English version	13
Fig. 8 Product label – original certification for ZONE 1	13
Fig. 9 Storing impulses in counters.....	19
Fig. 10 Processing of volumes during reversed flow	20
Fig. 11 Encoder SCR board (without cover)	23
Fig. 12 Inputs and outputs terminals.....	25
Fig. 13 Example of an impulse (binary) output and current output scheme	26
Fig. 14 Connecting of digital transducer with expansion module RS-485.....	28
Fig. 15 Placing of expansion module RS-485 in the device.....	28
Fig. 16 Safety separation of communication using RS-485 module DATCOM-K3 ...	30
Fig. 17 Safety separation of RS-232 communication via separator MTL 5051	31
Fig. 18 Communication cable wiring.....	31
Fig. 19 Removable foil strip at battery holder	44
Fig. 20 Significance of keys	46
Fig. 21 Basic navigation from the initial screen (FW 4.xx)	47
Fig. 22 Basic navigation from the initial screen (FW 2.xx)	48
Fig. 23 Device main menu and first submenu level	49
Fig. 24 Example of displaying the instantaneous values	50
Fig. 25 Navigation in archives (archiving period 15 min)	50
Fig. 26 Mounting of miniElcor to the mounting plate.....	58
Fig. 27 Mounting on the pipeline.....	58
Fig. 28 Temperature sensor mounting.....	60
Fig. 29 Temperature sensor mounting by the help of direct weldolet	60
Fig. 30 Shielding connection in bushing	62
Fig. 31 Consumption place setting	74
Fig. 32 Adding of new communication channel	76
Fig. 33 Base device parameters	77
Fig. 34 Data archive	77
Fig. 35 Base parameters – Full mode display.....	78
Fig. 36 Assistant for parametrization	79
Fig. 37 Parametrization of identification and communication.....	79
Fig. 38 Gas composition parametrization	80

Fig. 39	Channel setting.....	81
Fig. 40	Primary volume counter setting	82
Fig. 41	Displaying of device diagnostics	83
Fig. 42	Device archives clearing.....	84
Fig. 43	Password setting	85
Fig. 44	Gas meter constant setting in simple mode display.....	87
Fig. 45	LF gas meter constant setting in full mode display	88
Fig. 46	Setting of gas meter with HF output constant in full mode display.....	89
Fig. 47	Output pulses, switching on and off.....	90
Fig. 48	Pulse output inserting	91
Fig. 49	Pulse output parametrization	91
Fig. 50	Wizard for mathematical expression.....	93
Fig. 51	Equation for primary volume pulses and output connection	93
Fig. 52	Parameter V03 after equation assignment	94
Fig. 53	Analogue output setting	95
Fig. 54	Analogue output parametrization.....	95
Fig. 55	Wizard for analogue output equation making	96
Fig. 56	Resulting equation and connecting of analogue output on counted quantity.....	96
Fig. 57	Resulting setting of analogue output on output clamp DO3.....	97
Fig. 58	Setpoint setting	98
Fig. 59	Setpoint parametrization.....	99
Fig. 60	Displaying of device external power supply	100
Fig. 61	Monitoring setting of external power supply failure	101
Fig. 62	MODBUS map inserting	102
Fig. 63	Parameter of MODBUS map address.....	103
Fig. 64	Switch of communication protocol in the device	104
Fig. 65	106
Fig. 66	107
Fig. 67	107
Fig. 68	108
Fig. 69	111
Fig. 70	112
Fig. 71	112
Fig. 72	113
Fig. 73	113
Fig. 74	114
Fig. 75	114
Fig. 76	115

25 List of Tables

Table 1	Limitation of standard validity range of compressibility calculation	17
Table 2	Digital inputs setting options	21
Table 3	Options of archiving the individual quantities	35
Table 4	Service switch settings	40
Table 5	User access level (for “complete” meaning of the service switch)	42
Table 6	ASC access level.....	42
Table 7	Display status icons	47
Table 8	List of events – error messages (Err indication)	55
Table 9	List of events – warning messages (Wrn indication).....	56
Tab. 10	Assigning of weldolets and thermowells according to pipeline diameter	59
Tab. 11	Recommended cable types	61

MiniELCOR GAS-VOLUME CONVERSION DEVICE		
Prepared by:	Collective of authors	
Issued by:	ELGAS, s.r.o. Ohrazenice 211 533 53 Pardubice Czech Republic	Phone: +420 466 414 500, 511 Fax: +420 466 411 190 http://www.elgas.cz e-mail: sales@elgas.cz
Issued on:	January 2010	
Rev. no.:	Rev. 6g	

H065EN_201001_R6g_miniELCOR