

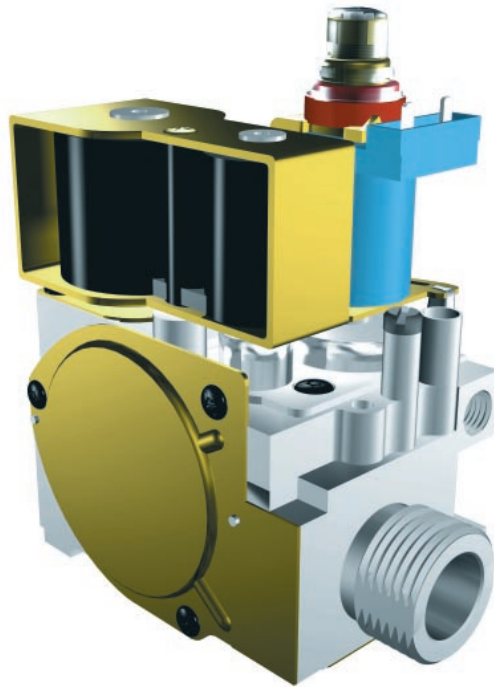

SIT Group

SIT 840-843-845 SIGMA



MULTIFUNCTIONAL CONTROL FOR GAS BURNING APPLIANCE

Application

Domestic gas appliances:
central heating boilers,
combi boilers, instantaneous
water heaters, space
heaters with automatic
ignition system.

Normative reference

EN 126.
Multifunctional devices for
gas burning appliances.

Main Features

Two automatic shut-off
valves.
Servo pressure regulator
On/Off (840), High/Low
control (843) or with full
electrical modulation (845).

Versions

840 ON/OFF
843 High/Low
845 Modulating



GENERAL DATA

CONSTRUCTION CHARACTERISTICS

- Aluminium body
- Two shut-off gas valves
- Side outlet option
- Inlet filter
- Pilot outlet (optional)
- Outlet and pilot filters (optional)
- Inlet and outlet pressure test point
- Connection for pressure regulator/combustion chamber compensation
- Two mounting holes
- Torsion and bending resistance group 2

USE SPECIFICATIONS

- Mounting position: any position
- Gas families: 1st, 2nd and 3rd
- Ambient temperature: 0...60 °C (-20 °C...60 °C on request)
- Maximum inlet pressure: 60 mbar

MECHANICAL CONNECTIONS

- Gas inlet and outlet: G 3/4 ISO 228
or: M4 (4) (flanges) minimum full thread 6 mm
or: Rp 1/2 ISO 7 (105 mm version)
- Side Outlet: M5 (3) (flanges) minimum full thread 7 mm
- Pilot: M10x1 for 4 mm, 6 mm or 1/4" tubing
- Pressure test point: ø 9 mm
- Pressure compensation: ø 7 mm

ELECTRICAL CONNECTIONS

- Automatic shut-off valves: Male contact 3003 Molex compatible, suitable for female Molex series 3001
- Electrical modulator: male fast-on connector 2.8 x 0.8 mm

ELECTRICAL DATA

AUTOMATIC SHUT-OFF VALVES	EV1	EV2	EV1	EV2
Nominal Supply Voltage (AC)	Current at nominal voltage (mA)		Power at nominal voltage (W)	
230 V 50 Hz Vac	40	12	4.3	2.0
24 V 50 Hz Vac	390	100	4.6	2.0
24 V 50 Hz RAC	270	115	6.5	2.8

Protection degree:

IP 40 with SIT NAC 504 connector. IP 44 with SIT NAC 504 connector and Gasket.

IP 40 or IP 44 with EV connector Serie 960.4.

DESCRIPTION

- 1 On-off solenoid valve EV1.
- 2 On-off solenoid valve EV2.
- 3 Inlet pressure test point.
- 4 Outlet pressure test point.
- 5 Connection for pressure regulator / combustion chamber compensation.
- 6 Servo-pressure regulator.
- 7 Gas outlet pressure modulator.
- 8 Pilot outlet.
- 9 Main gas outlet.
- 10 Side outlet.
- 11 Slow opening device.

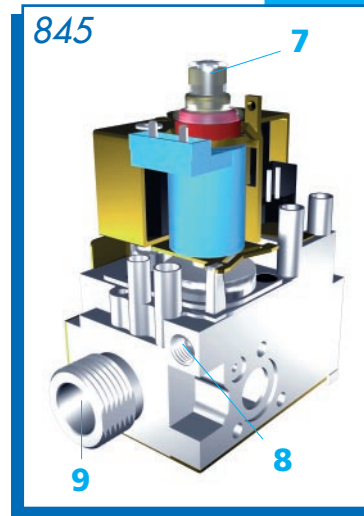
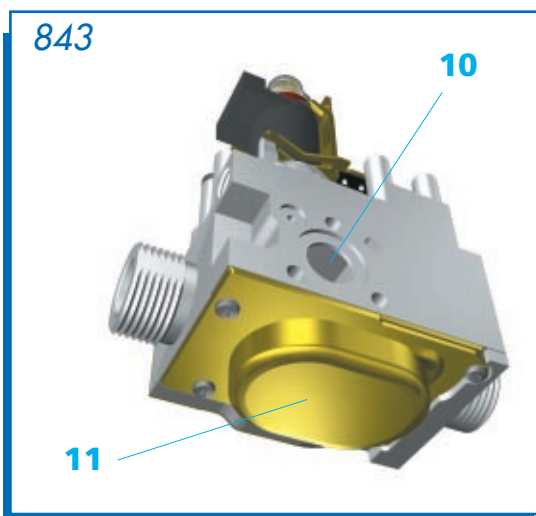
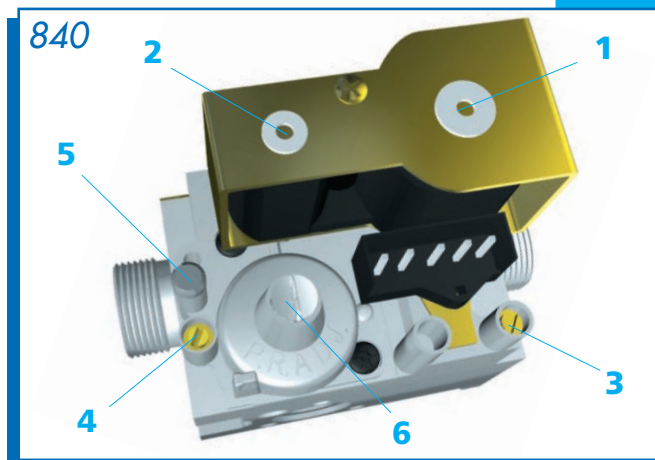

CONNECTION DIAGRAM

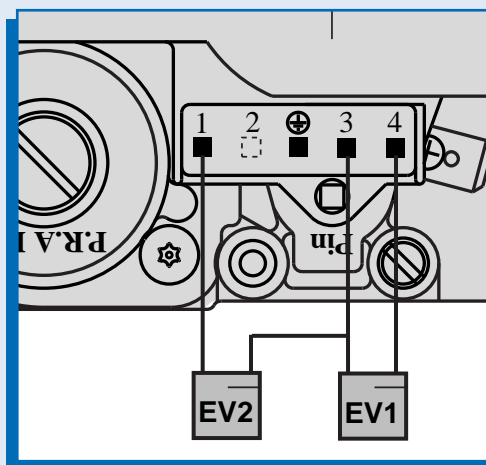



FUNCTIONS

FUNCTIONS

- Automatic gas shut-off
 - On-off solenoid valve EV1 class A or B
 - On-off solenoid valve EV2 class C or J
 - Closing time ≤ 1 second

- Pressure regulation
 - Servo pressure regulator class B
 - with reference to EN 126

- Slow opening
 - Optional on 840 and 843
 - Adjustable version on request

- Gas outlet pressure electrical modulation

843 SIGMA
 High/Low modulation (black coil)
 Modulation Range 3-50 mbar
 Nominal Supply Voltage 230 V 50 Hz Rectified AC
 Protection Degree IP40 or IP44 with connector serie 960.4
 Power 2.8 VA

845 SIGMA
 Continuous modulation
 Modulation range 1-37 mbar (modulator in horizontal position)
 Electric Supply 9 V 310 mA (white coil)
 17 V 165 mA (light blue coil)

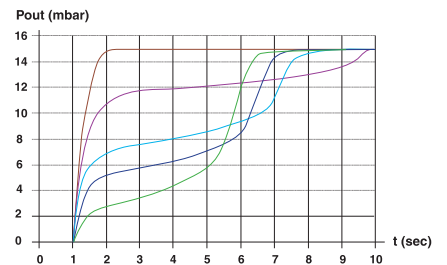
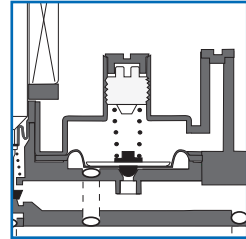
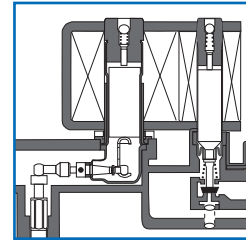

845

Pressure/current characteristic

Tolerance band (increasing current).
 Modulator axis in horizontal position.

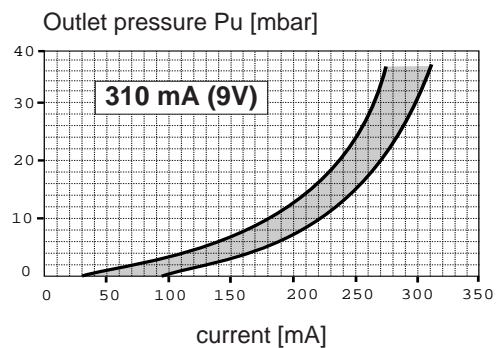
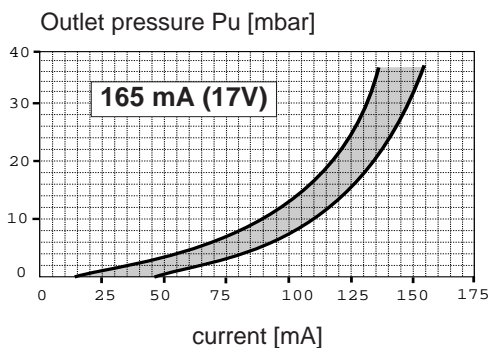

SYSTEMS

84X SIGMA - 537 ABC

Combined system - gas control/automatic burner control suitable for either an appliance with natural draught or fan assisted.

537 ABC Characteristics:

- Specifically designed for SIGMA gas control.
- Direct burner ignition (DBI) or by intermittent pilot (IP).
- Manual or non-volatile lockout with reset and indicator integrated or fitted remotely.

For further information see the specific technical sheet 537 ABC code 9.955.486

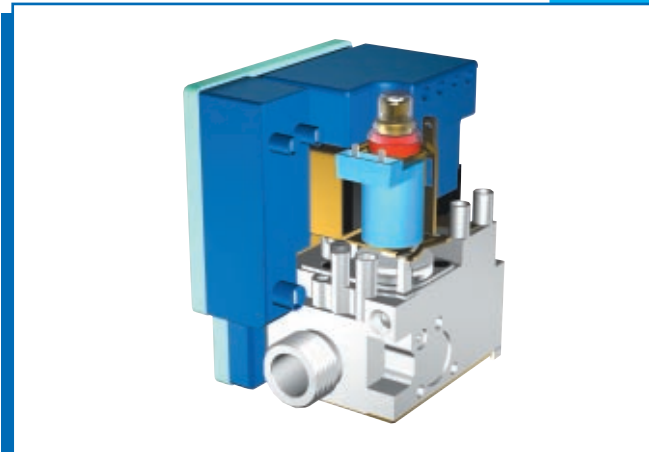

84X SIGMA - 505 EFD - 504 NAC

Combined system gas control, automatic burner control, connector with integrated igniter.

505 EFD Characteristics:

- Suitable to be used with 230 Vac external igniter like 504 NAC.
- Direct burner ignition (DBI) or by intermittent pilot (IP).
- Remote manual resetting function and signalling of the lockout state.

504 NAC Characteristics:

- Connector with integrated igniter specifically designed for SIGMA gas control.
- Protection degree IP40. IP44 available on request.

For further information see the specific technical sheet 504 NAC - 505 EFD code 9.955.457

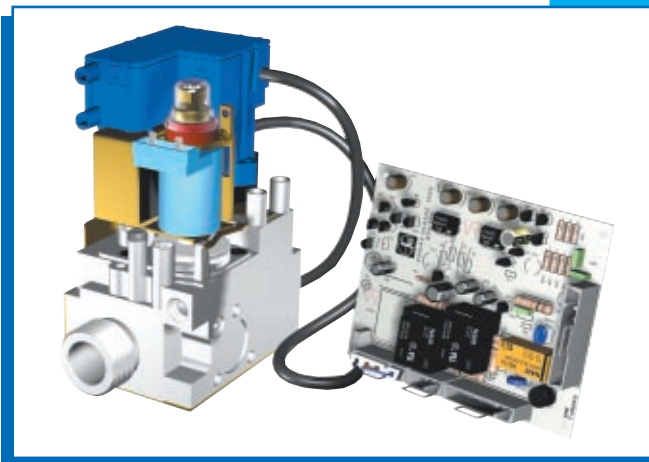

ACCESSORIES

Main voltage electric supply connector (Z)

- 3 or 4 wires power versions available.
- Protection degree IP40 or IP44.

843 Modulator supply connector

- Integrated rectified circuit
- Protection degree IP40 or IP44

845 Modulator supply connector (V)

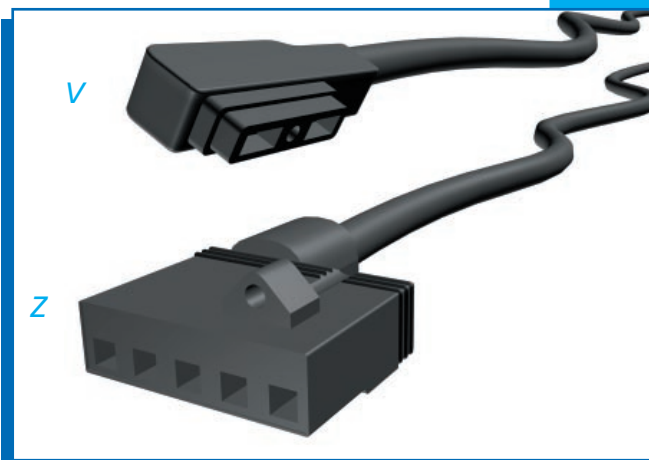



CAPACITY

FLOW RATE Q AS A FUNCTION OF PRESSURE DROP ΔP

solenoid valves class B+J

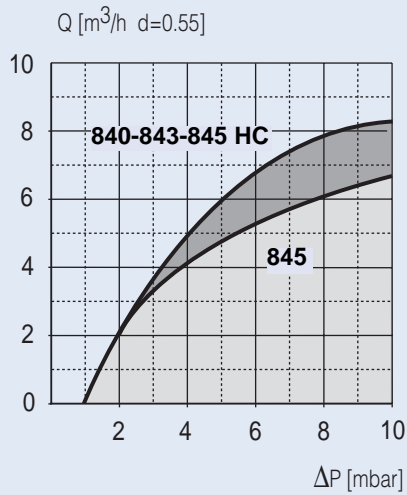

solenoid valves class B+C

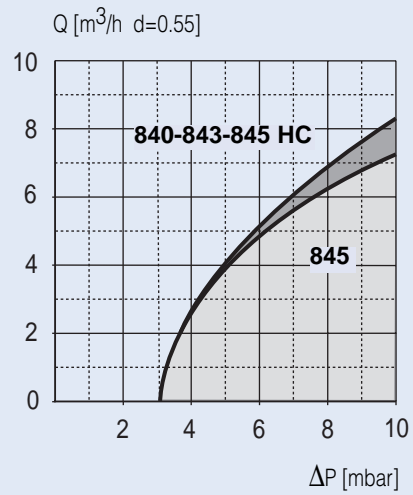

flowrate at $\Delta p = 5$ mbar

gas family	845		840-843-845 HC	
	B+J	B+C	B+J	B+C
1 st d=0.41	5.2 m ³ /h	4.4 m ³ /h	7 m ³ /h	4.6 m ³ /h
2 nd d=0.55	4.5 m ³ /h	3.8 m ³ /h	6 m ³ /h	4 m ³ /h
3 rd d=1.55	2.6 m ³ /h	2.3 m ³ /h	3.6 m ³ /h	2.4 m ³ /h

845 HC: High Capacity Version

CAPACITY

REGULATED FLOW RATE Q IN ACCORDANCE WITH EN 126

845
solenoid valves class B+J

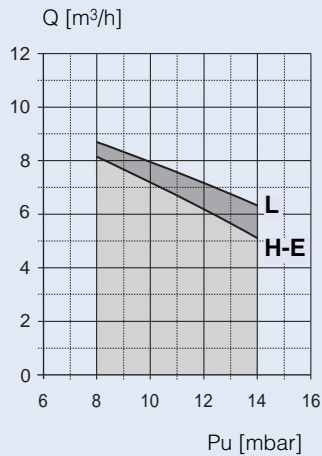

845
solenoid valves class B+C

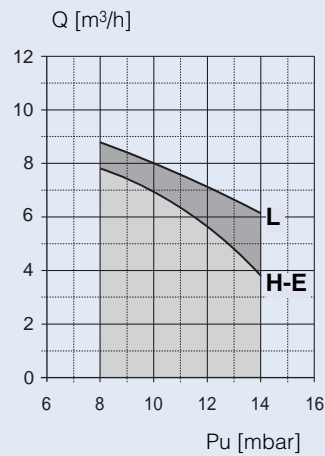

840-843-845 HC
solenoid valves class B+J

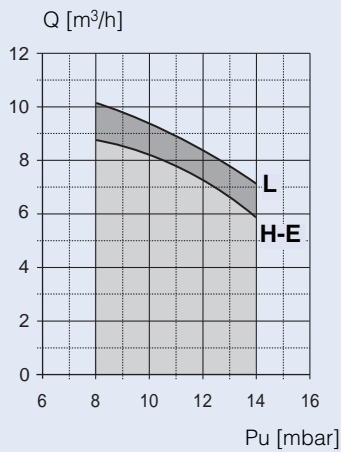

840-843-845 HC
solenoid valves class B+C

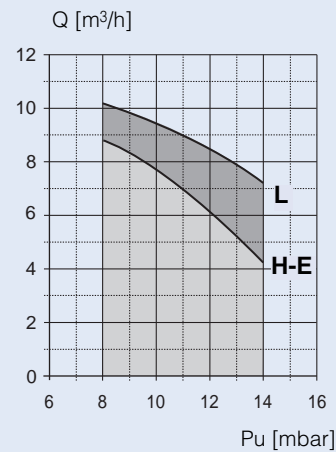

Second Family Group H, E and L

	Inlet pressure range (mbar)			
	Nominal	Max	Min	Relative Density
H-E	20	25	17	0.555
L	25	30	20	0.612

Minimum flowrate 0.3 m³/h d=0.55

845 HC: High Capacity Version

OPERATION PRINCIPLE

845

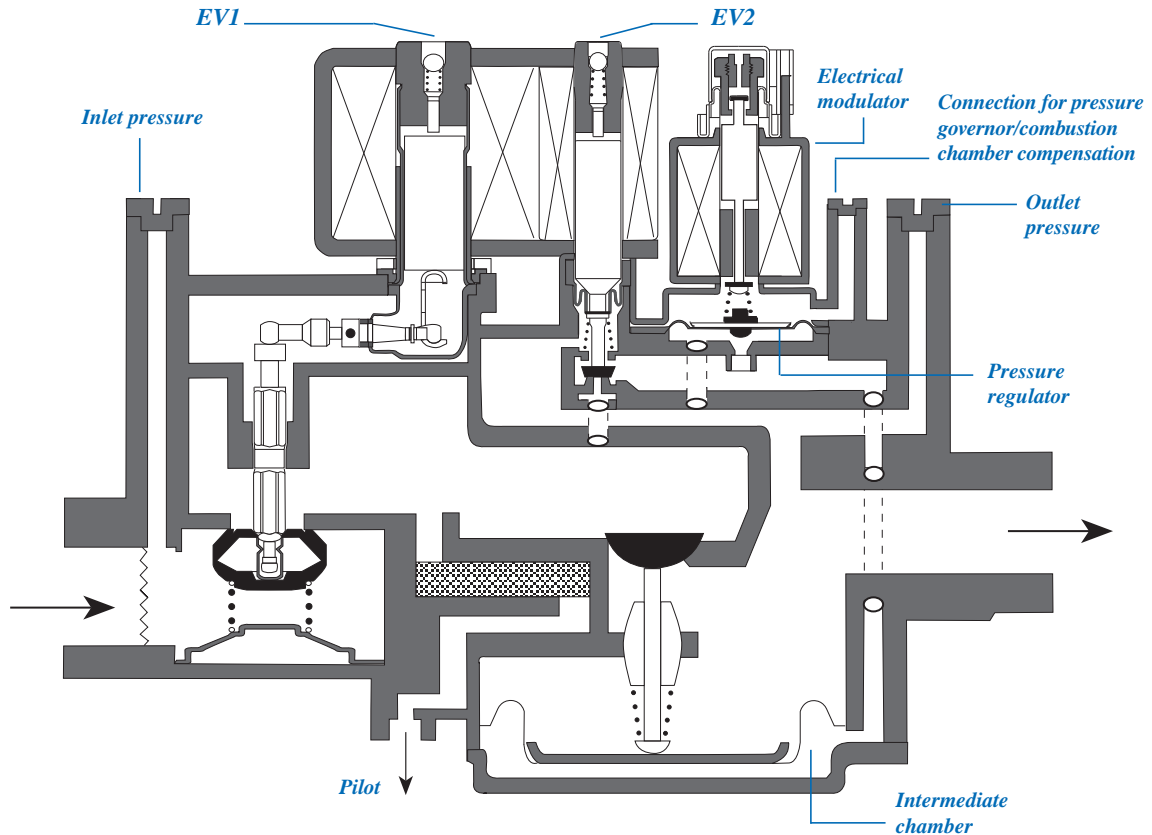

SIGMA has two automatic solenoid shut-off valves.

- When the solenoid (EV1) is energised the first gas valve opens.
- The second solenoid (EV2) allows the gas to flow through the servo circuit. The pressure under the main servo diaphragm increases and consequently the servo valve opens.

In case of gas or power supply failure the spring pressure assures the automatic closure of the gas valves.

The outlet pressure regulation is performed by the servo system.

When the outlet pressure is greater than the value driven by the modulator, the pressure regulator valve opens and as a consequence the pressure under the main servo diaphragm decreases closing the main valve. Therefore the outlet pressure goes back to the preset value. Vice versa if the outlet pressure is smaller than the preset level the pressure regulator closes and therefore the servo pressure increases opening the main valve.

SLOW OPENING

An extra chamber with diaphragm and spring are inserted on 840 SIGMA.

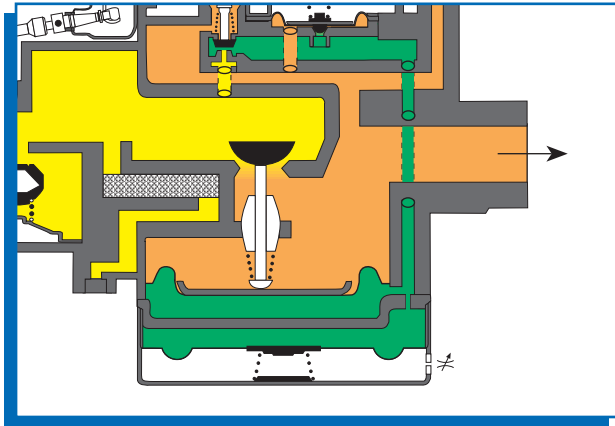

When the EV2 opens the servo circuit the gas enters in the slow-opening chamber. The gas pressure under the main valve diaphragm goes to a certain level and partially opens the gas way. The pressure is not increased because of the movement of the slow opening diaphragm.

In the adjustable slow opening version, by using the proper regulating screw, the pressure rise and the opening time can be changed between set limits.

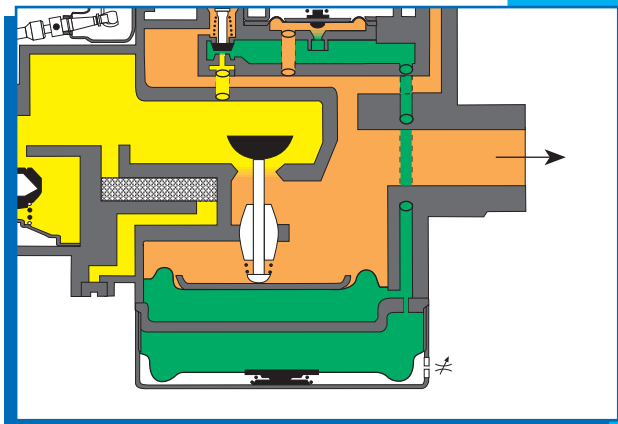
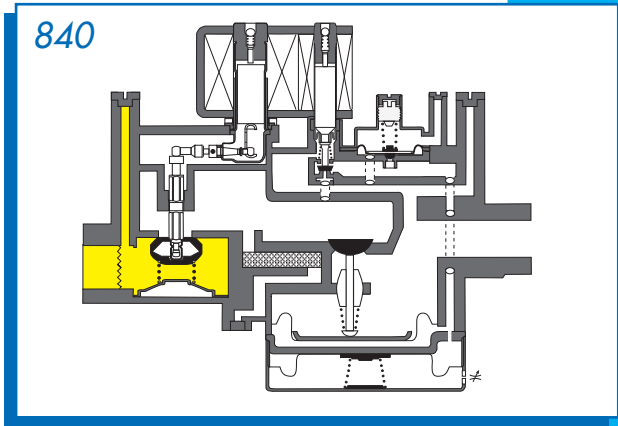

After a certain time, the slow-opening spring is completely compressed and therefore there is no more volume variation and the pressure under the main diaphragm increase rapidly, completely opening the main valve.

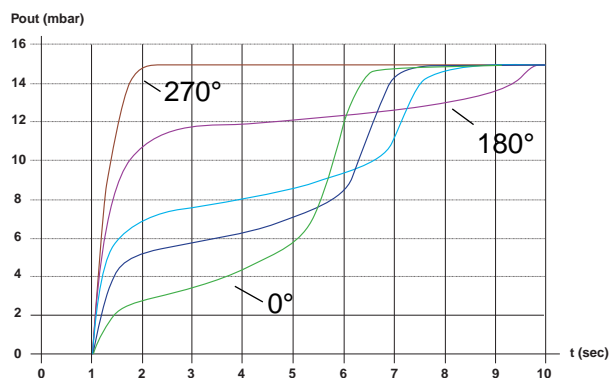
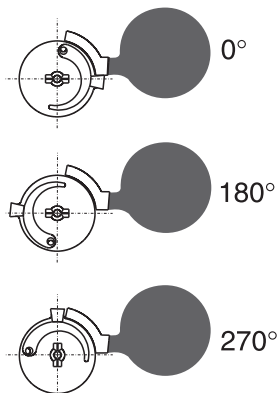
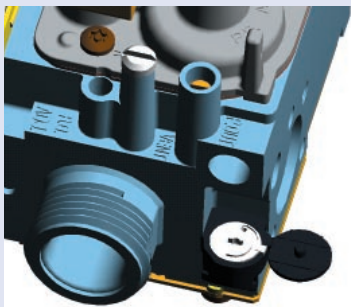



840 OUTLET PRESSURE ADJUSTMENT

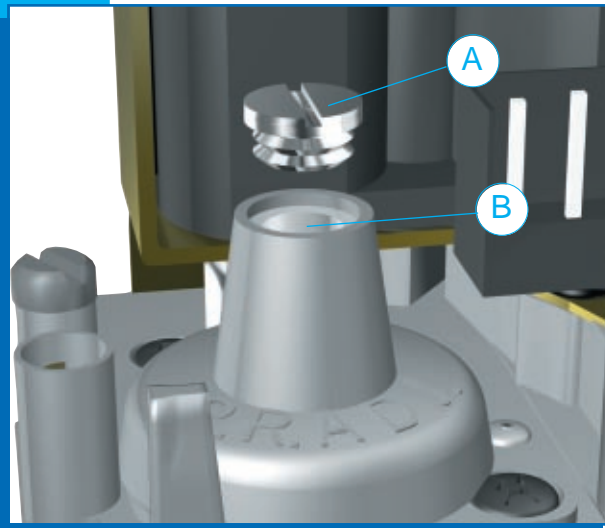

All adjustments must be made on the basis of the specific characteristics of the appliance. Check inlet and outlet pressure using the pressure test points provided. After testing, carefully seal test points with the provided screws. Recommended torque: 1.0 Nm.

Disconnect pressure regulator connection "VENT" (if used).

Remove the protective plug A.

Screw in the screw B to increase the pressure and screw it out to decrease it.

After setting put back the protective plug.

843/845 OUTLET PRESSURE ADJUSTMENT

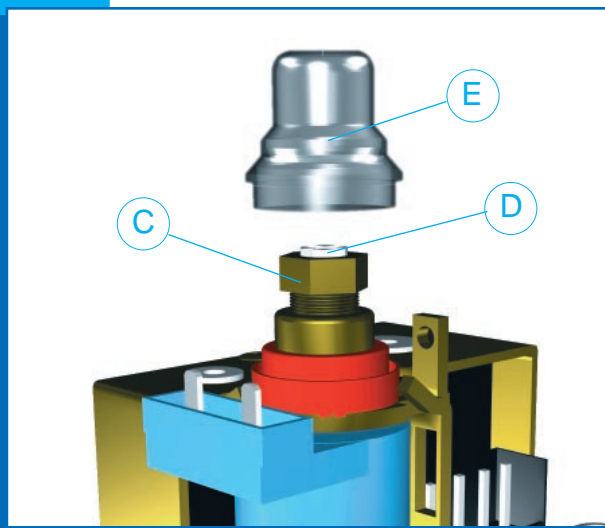

All adjustments must be made on the basis of the specific characteristics of the appliance. Check inlet and outlet pressure using the pressure test points provided. After testing, carefully seal test points with the provided screws. Recommended torque: 1.0 Nm.

Disconnect pressure regulator connection "VENT" (if used).

Remove the modulator plastic cap E.

- Maximum pressure: power the modulator in the maximum condition. Screw in the nut C to increase the outlet pressure and screw it out to decrease it. Use a 10 mm spanner.

- Minimum pressure: Turn off the power supply to the modulator and, keeping the nut C stationary, screw in the screw D to increase the pressure and screw it out to decrease it. Screwdriver 6 x 1 blade. Carefully put back the modulator plastic cap. Reconnect pressure regulator connection (if used).

845

Outlet pressure P_u [mbar]

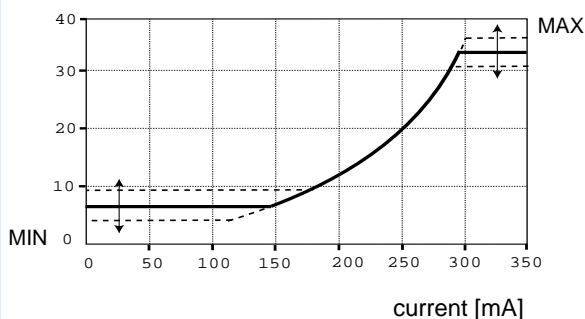

840 DIMENSIONS

Gas connection: G3/4 ISO 228

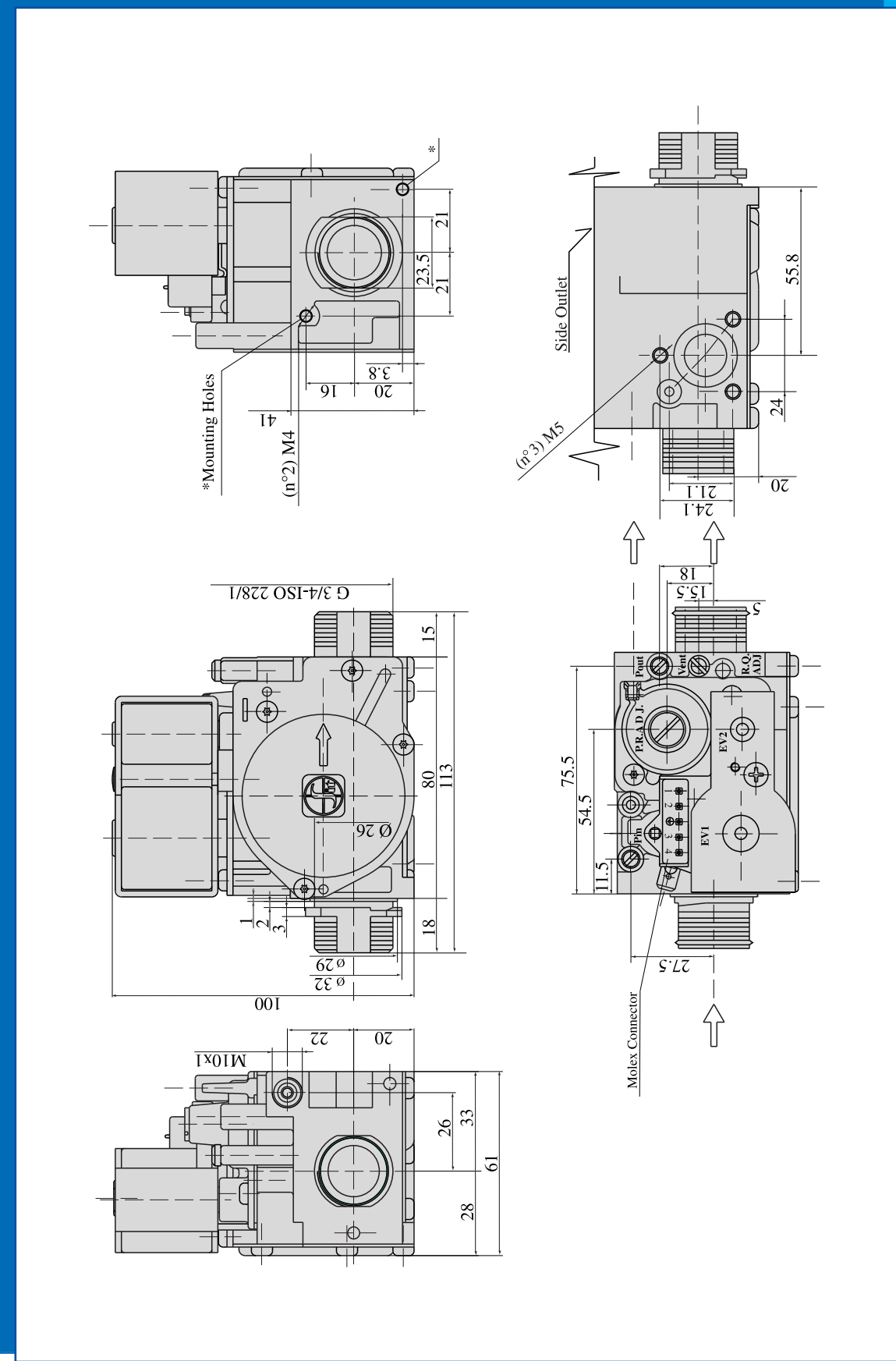



840 DIMENSIONS

Gas connection: Flanges

105 mm version
Optional Rp 1/2 ISO 7
inlet and outlet connection

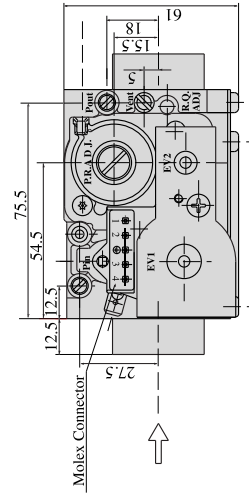
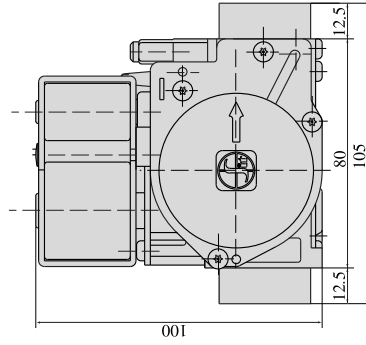

80 mm version

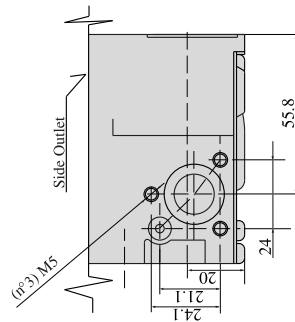
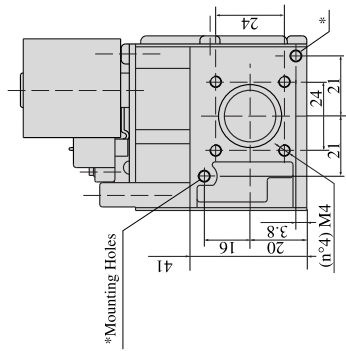
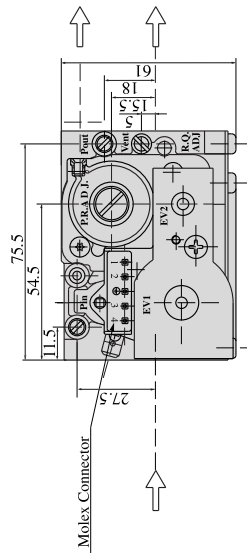
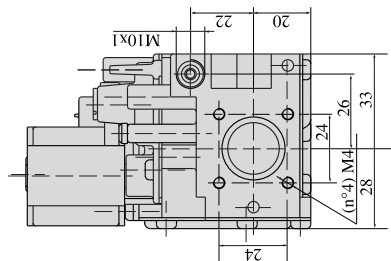

840 DIMENSIONS SLOW OPENING VERSION

Gas connection: G3/4 ISO 228

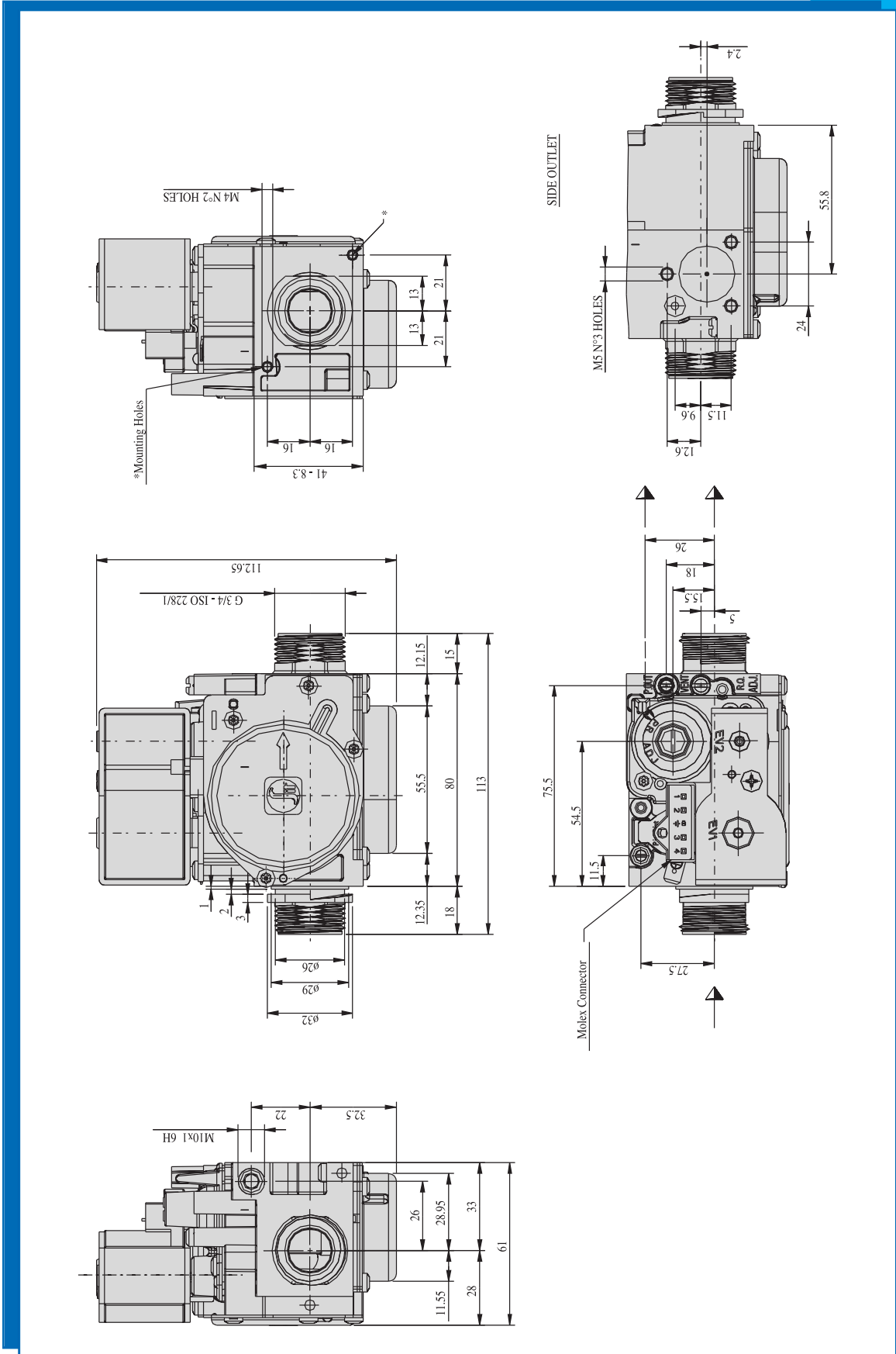



843/845 DIMENSIONS

Gas connection: G3/4 ISO 228

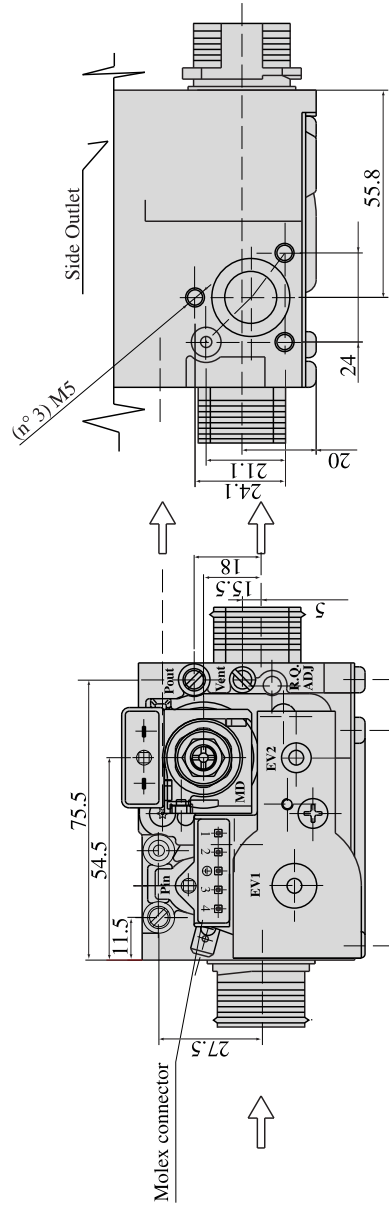
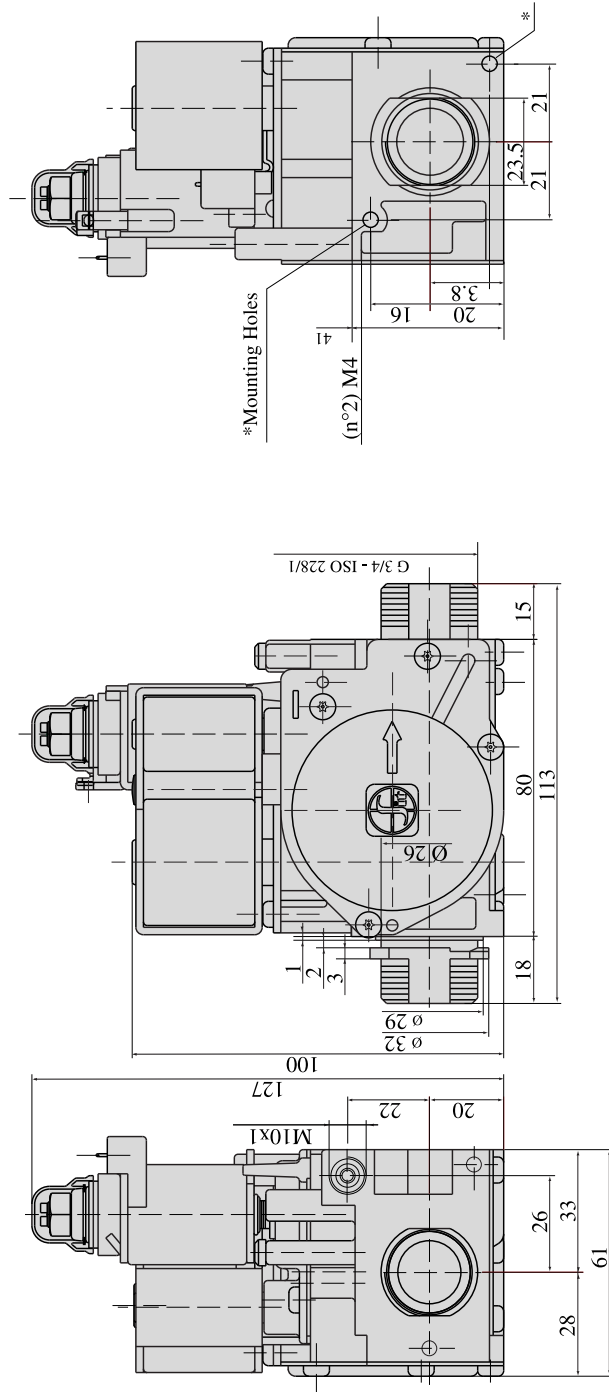

843/845 DIMENSIONS

Gas connection: Flanges

105 mm version
Rp 1/2 ISO 7 version
available on request

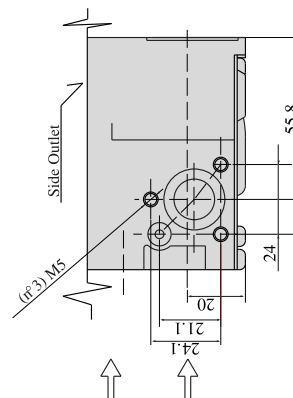
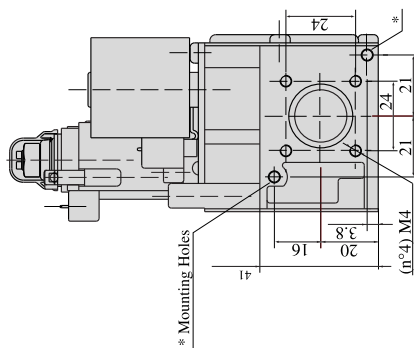
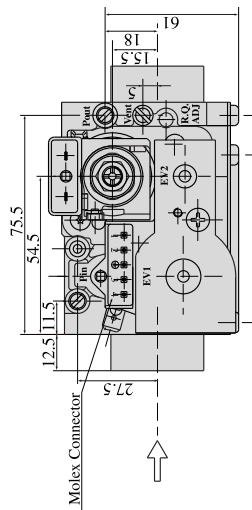
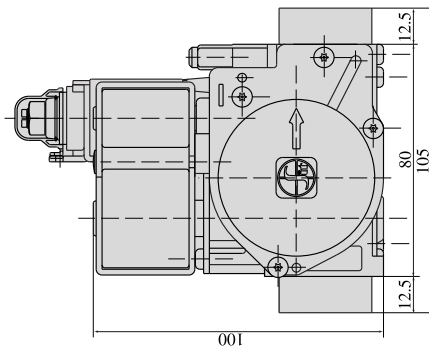

80 mm version

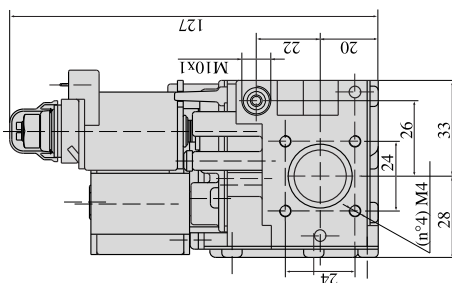
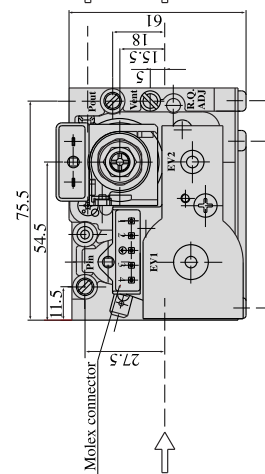
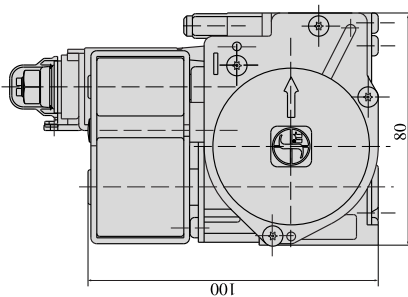



SITGroup

SIT La Precisa S.p.A.

Viale dell'Industria 31-33

35129 PADOVA - ITALY

Tel. +39/049/829.31.11, Fax +39/049/807.00.93

www.sitgroup.it - e-mail: mkt@sitgroup.it
