



Efficient Installation

Mounting Methods Guide

Table of Contents

3 Introduction

4 Section 1: Mounting Hardware

4 Hardware

7 Weather shields

8 Section 2: Direct Coupled Applications

Single and multiple actuator mounting

14 Section 3: Non-Direct Coupled Applications

Single and multiple actuator mounting

17 Jackshafts

18 Inlet vanes

19 Section 4: Conduit Connections

20 Section 5: Damper Linkages

22 Special applications

Damper Types and Installation Methods

Belimo direct coupled actuators are designed to minimize installation cost by directly coupling to the damper shaft, making actuation the simplest and most reliable method to control airflow in HVAC systems.

With the range of damper types and installation methods, many accessories have been developed to make these actuators even more versatile. Belimo actuators can virtually be used for any new or retrofit HVAC application offering:

1. Easy installation
2. 5-year warranty
3. Overload proof
4. UL and CSA listed
5. NEMA housings
6. Manual override
7. ISO 9001 Quality Assurance
8. Proven average failure rate of less than 0.3%

This handbook is a collection of actuator damper installations showing common and some not-so-common HVAC applications. Future product developments may further simplify mounting methods, contact your local distributor or Belimo District Sales Manager.



Section 1: Mounting Hardware

When appropriately installed, anti-rotation bracketing should allow some actuator float (or play.) The pin should not be buried into the slot, preventing movement or failure can occur. The anti-rotation pin is to be centered in the anti-rotation slot. The actuator base should also be parallel to the mounting surface. It is imperative that trade best practices are upheld to ensure connecting components and bracketing remain straight and true, maintaining alignment and proper product performance. Mechanical tuning may be required.

Figure 1.1: Anti-rotation strap

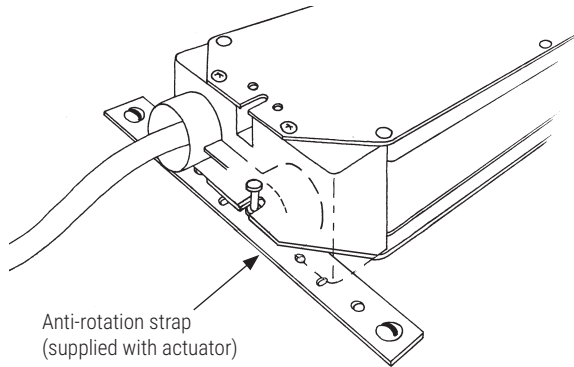

Figure 1.2: Anti-rotation strap shown mounted on an angle

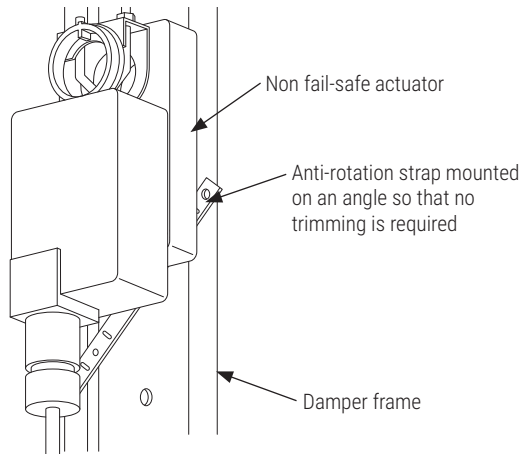
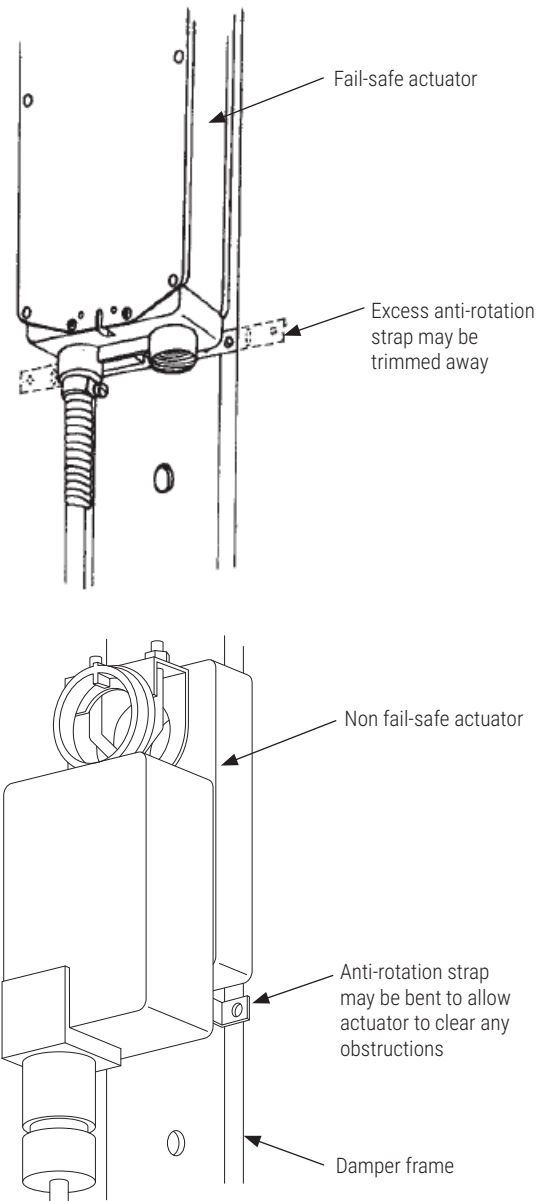

Figure 1.3: ZG-JSL linkage

Designed to facilitate the attachment of select Belimo actuators to a damper's jackshaft. The unique open ended design allows the linkage to clamp on to any part of a jackshaft measuring from ½" to 1.05" in diameter.



Figure 1.4: Modification of the anti-rotation strap



Additional options available depending on application requirements:

- AV8-25 (5/16" to 1" diameter shafts)
- ZG-JSA-1
- ZG-JSA-2
- ZG-JSA-3
- ZG-JSL
- ZG-NMSA-1
- ZG-LMSA
- ZG-LMSA-1

Figure 1.5: Identifying the major components of Belimo direct coupled actuators

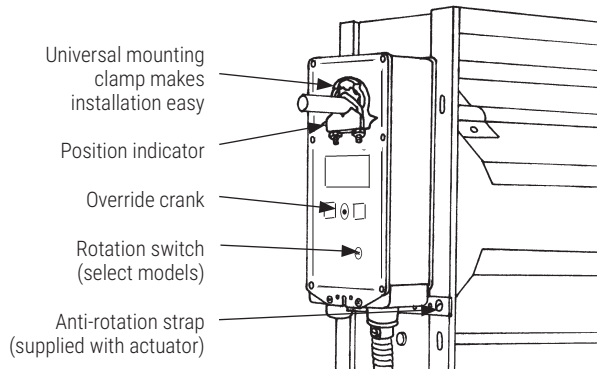

Figure 1.6: mounting brackets; for use when direct coupling is impossible

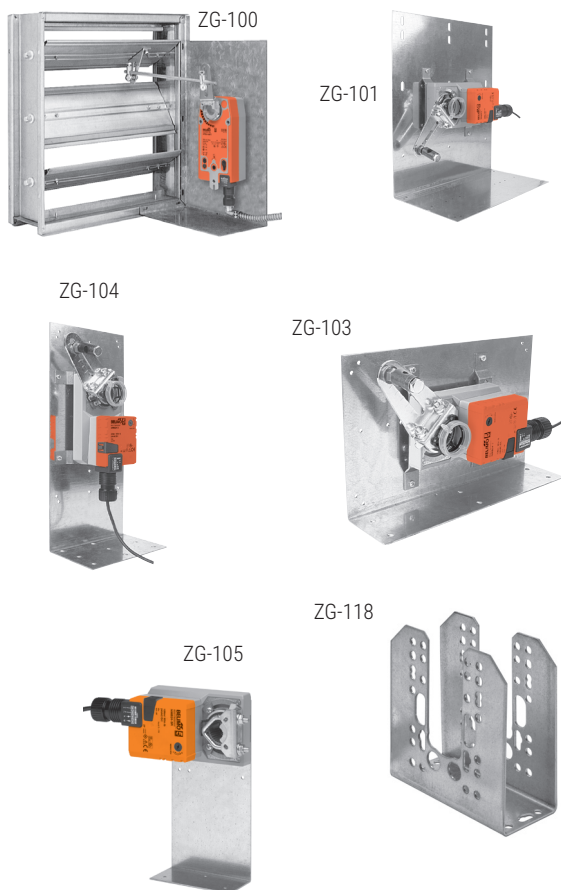

Figure 1.7: KH universal crank arms are shown with available ball joints

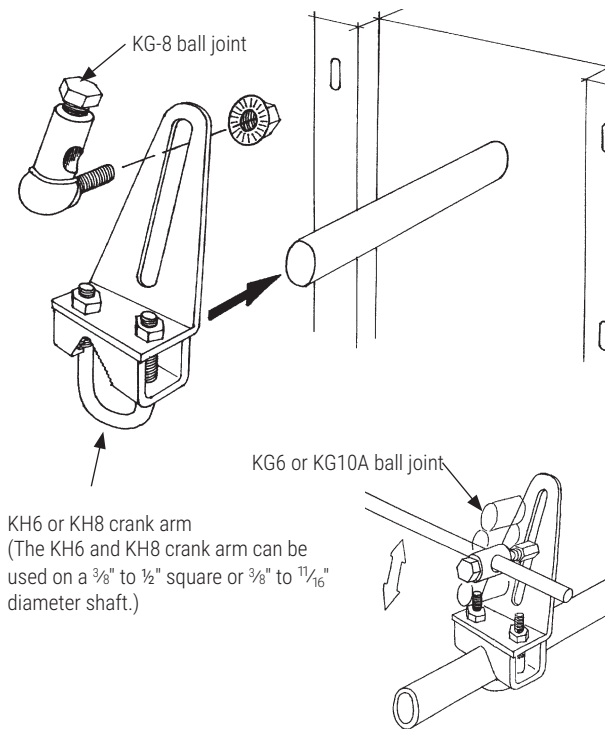

Figure 1.8: ZG-TF2 damper linkage kit

Damper linkage kits are available for all product series.

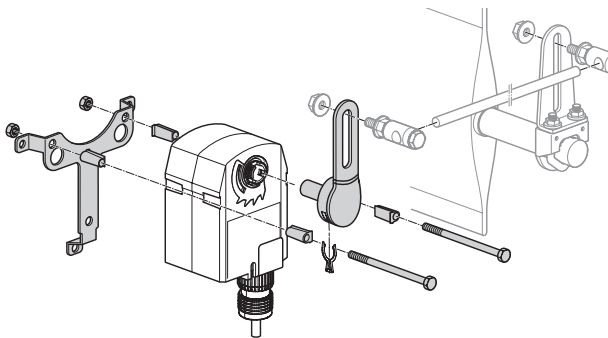
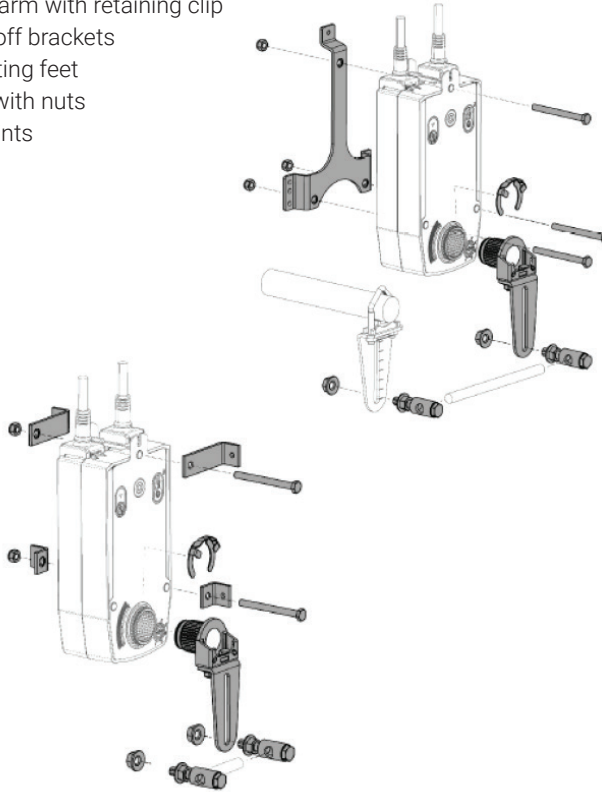

Figure 1.9: ZG-AFB damper linkage kit

Kit contains:

- 1 crank arm with retaining clip
- 2 standoff brackets
- 4 mounting feet
- 2 bolts with nuts
- 2 ball joints

**Figure 1.10: ZG-AFB118 damper linkage kit**

The ZG-AFB118 includes the ZG-118 universal mounting bracket and KH-AFB crank arm and is designed for applications where the actuator cannot be mounted directly to the damper shaft. It may be used for outside or inside the duct mounting.

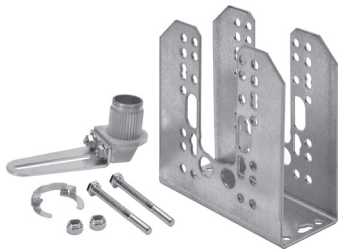
**Figure 1.11: Z-DS1 damper linkage for linear actuator**

Rotary support for use with linear actuator for compensation of transverse forces.

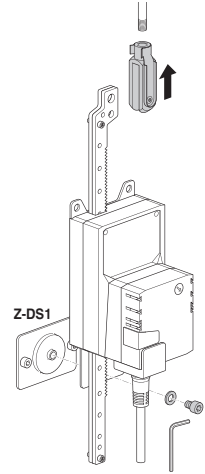
**Figure 1.12: ZS-100 weather shield**

Supplied disassembled. If desired, a side or end can be deleted from the assembly to provide easy access from the bottom of the enclosure, and a hole punch can be used to mount a wire conduit. A foam gasket is provided to achieve a better seal. For a weather tight installation assemble all sides and use a silicon sealer on all seams.

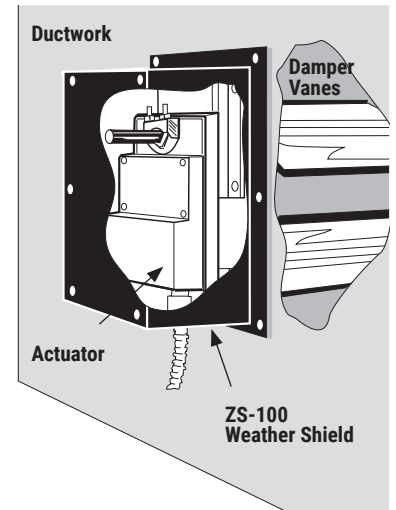

Figure 1.13: ZS-150 weather shield

Supplied as a one piece enclosure. Two 7/8" wiring holes are pre-drilled to allow secure connections of conduit to the housing. If connections are needed in a different or only one hole is required, two plastic plugs are provided to seal the hole(s). A foam gasket is provided to achieve a better seal.



Figure 1.14: ZS-300 NEMA 4X, 304 stainless steel housing for harsh environments

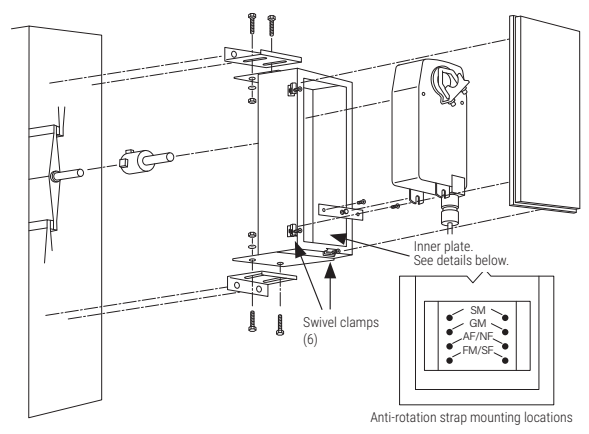
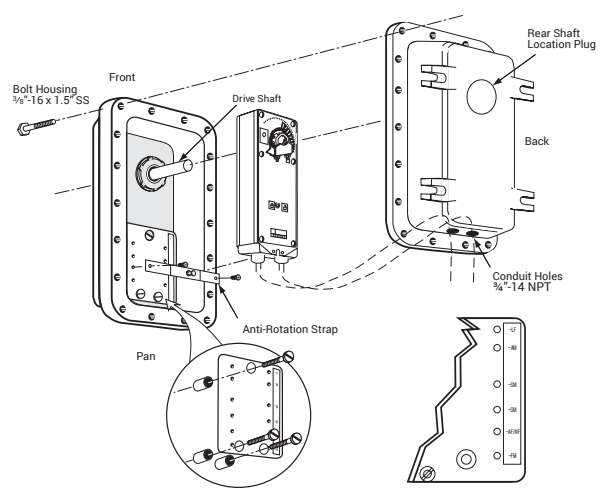
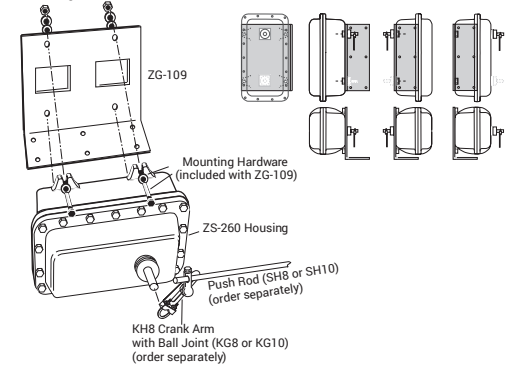

Figure 1.15: ZS-260 explosion-proof housing with available ZG-109 and ZG-110 mounting brackets



Typical ZG-109 Mounting



Typical ZG-110 Mounting

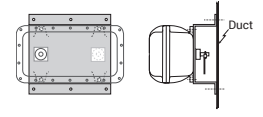
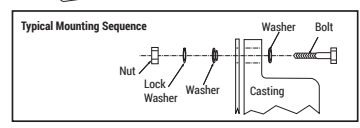
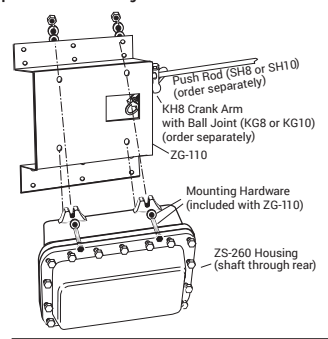

Section 2: Direct Coupled Applications

Direct coupled mounting

Belimo actuators can be mounted in any position.

Figure 2.1: Standard mounting

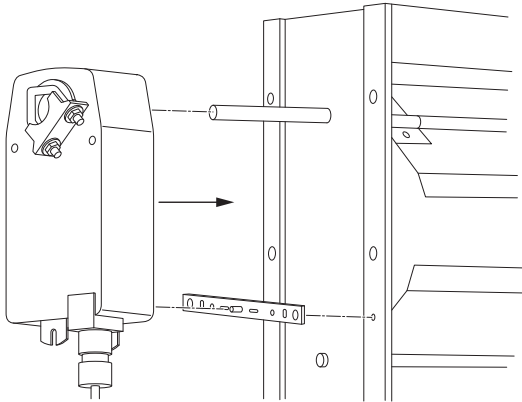

Figure 2.2: Universal mounting clamp

The clamp is most often mounted on the front of the actuator body but can be installed on the back for short shaft installations.

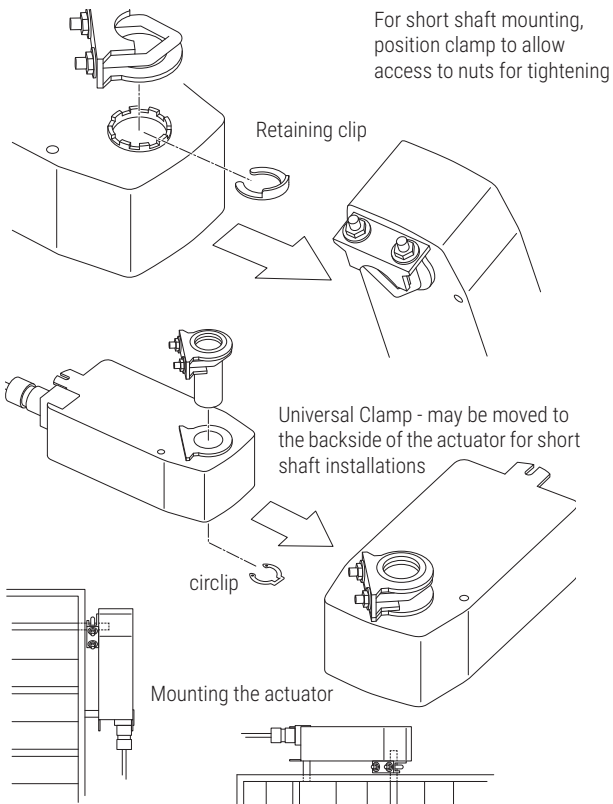
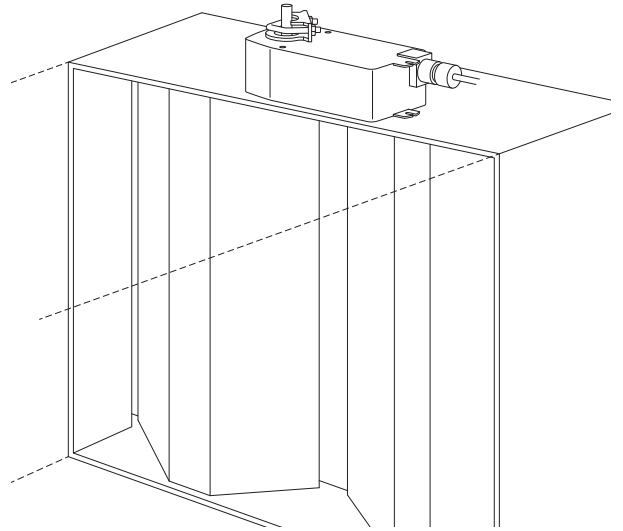

Figure 2.3: Fastened directly to the duct work



It is imperative that standard trade practices are upheld to ensure connecting components and bracketing remain straight and true, maintaining alignment and proper product performance.

Figure 2.4: Mounting to angular ductwork use the AV6-20 or AV8-25 shaft extension and a field fabricated bracket

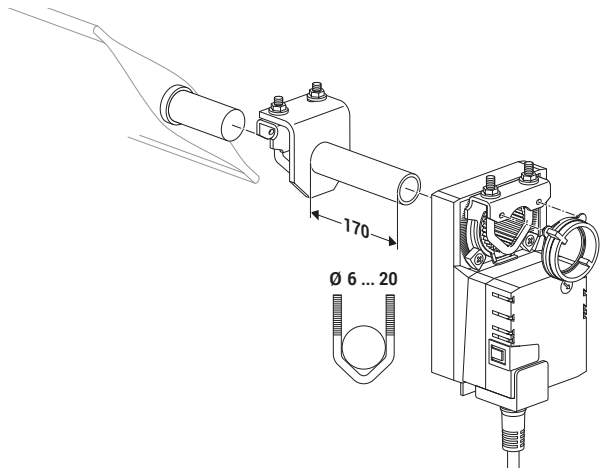

Figure 2.5: Field fabricated mounting plate

Used to attach actuator to exposed damper frame when there is not enough clearance from the wall to mount the actuator in the standard configuration.

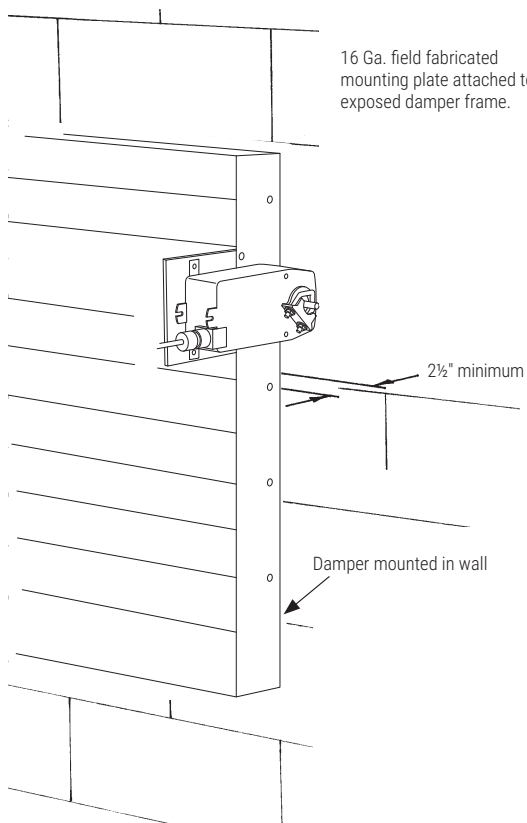

Figure 2.6: Multiple actuators mounting using the fully adjustable ZG-102 mounting bracket



Figure 2.7: Multiple dampers directly connected to one actuator with linkage to operate the both dampers

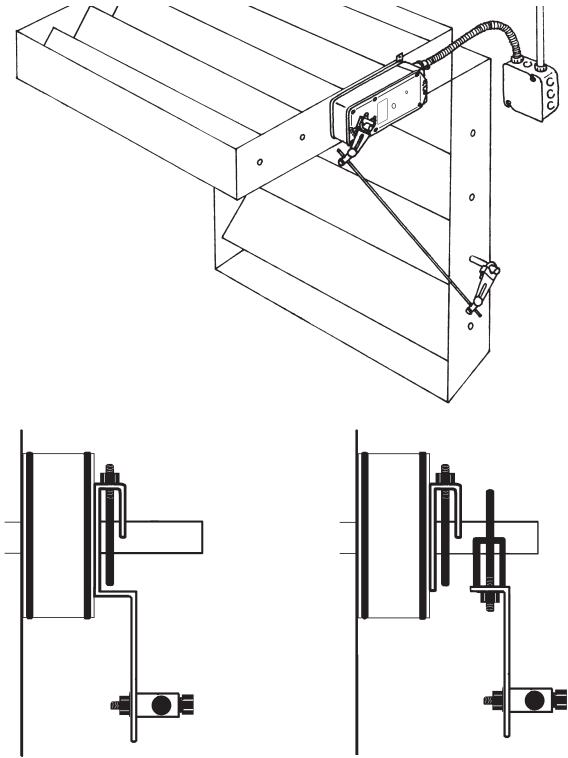

Figure 2.8: Multiple stacked dampers connected to one actuator with linkage to operate both dampers

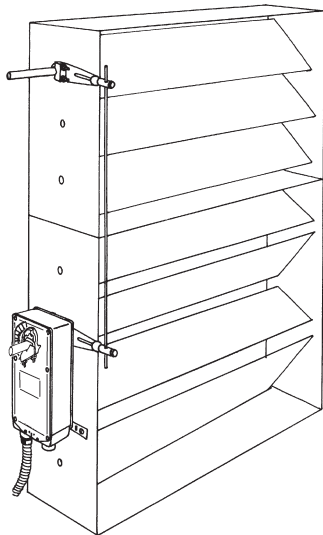
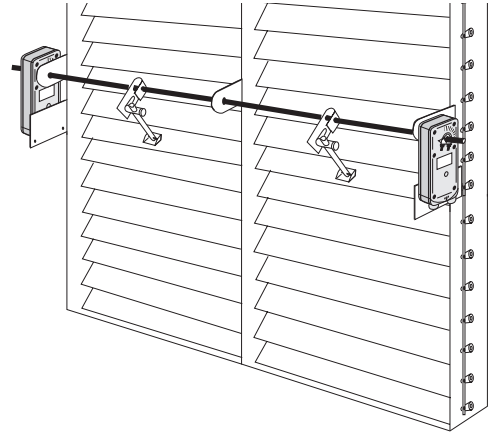
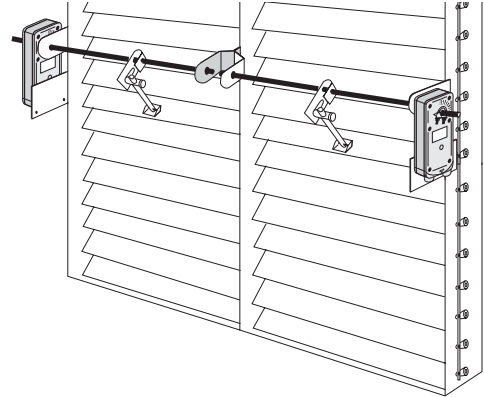

Figure 2.9: Controlling multiple damper assemblies

A. Multiple dampers side by side connected to one actuator with linkage to operate both dampers.



B. Multiple dampers side by side with separate shafts and actuators.



C. Multiple dampers side by side with individual mounted actuators in close proximity with no jackshaft.

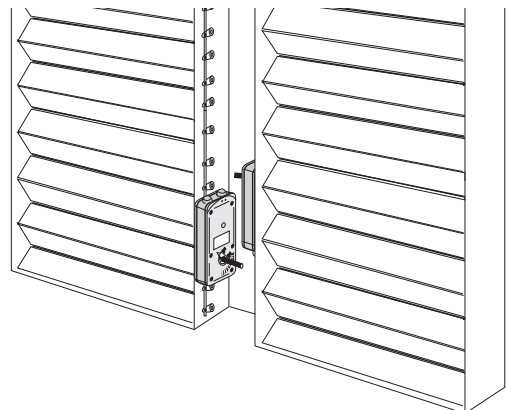

Figure 2.10: Actuator mounted to a jackshaft

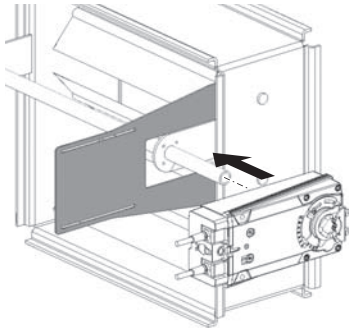

Figure 2.11: Actuator mounted to ductwork and jackshaft

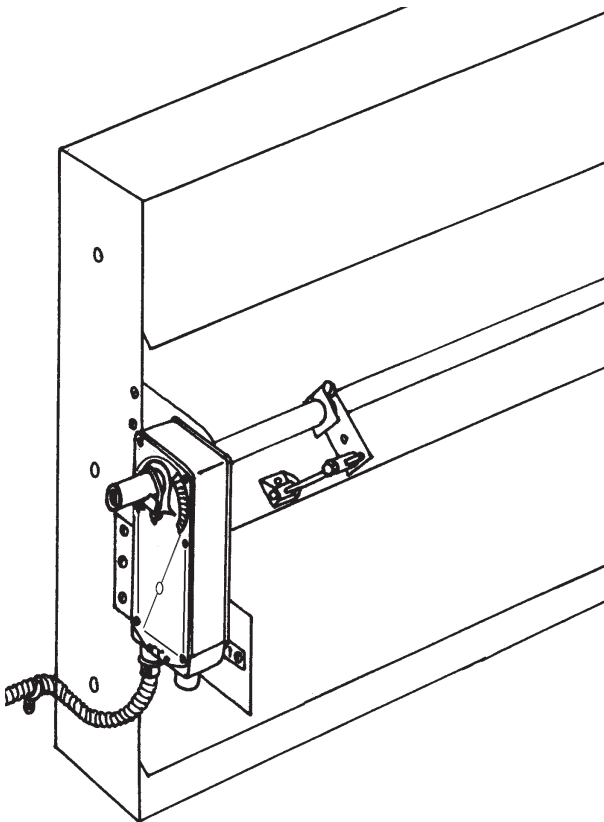
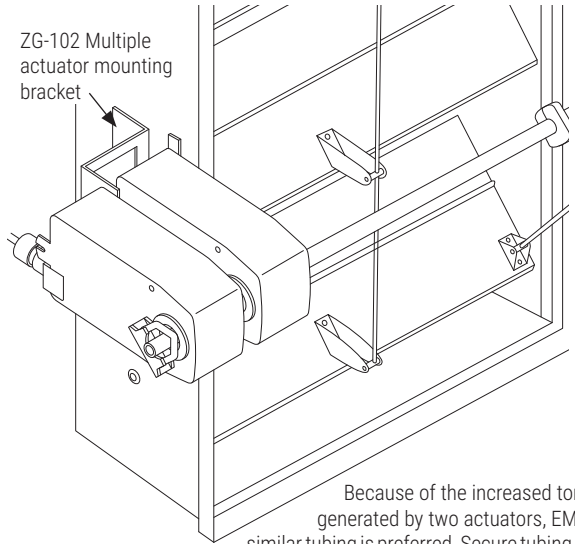

Figure 2.12: Multiple actuators mounted to a jackshaft



Because of the increased torque generated by two actuators, EMT or similar tubing is preferred. Secure tubing with 1/4" machine screws with nylon hex lock nuts.

Figure 2.13: Linkage examples for multiple dampers connected to multiple actuators

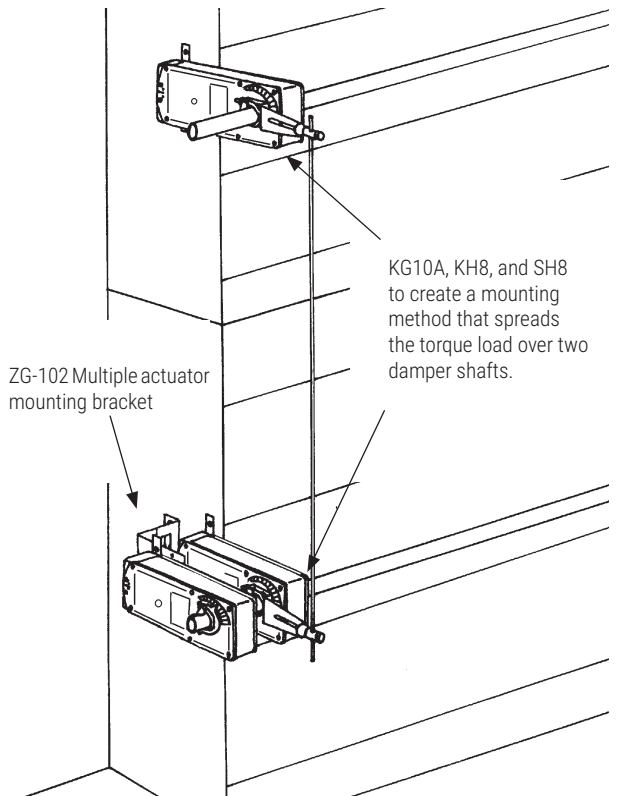

Figure 2.14: Jackshaft inside ductwork

Mounting of actuators inside ductwork. If the jackshaft diameter is larger than the actuator will accept, use either EMT tubing or a JSA shaft adapter.

Two solutions:

For a $\frac{3}{16}$ " I.D. jackshaft, slide the $\frac{1}{2}$ " EMT into jackshaft and secure by bolting through with $\frac{1}{4}$ " -20 machine screws. For jackshafts that have a larger I.D. use EMT or similar tubing with a maximum I.D. difference of no more than $\frac{1}{16}$ ". Use nylon insert hex lock nut to keep bolts from loosening up. Secure the actuator.

Less time consuming method preferred by installers use ZG-JSA-1, ZG-JSA-2, or ZG-JSA-3 jackshaft adapter designed to be inserted into the hollow jackshafts. Placed into the jackshaft and tightened the tension nut to expand against the inner shaft. Secure the actuator.

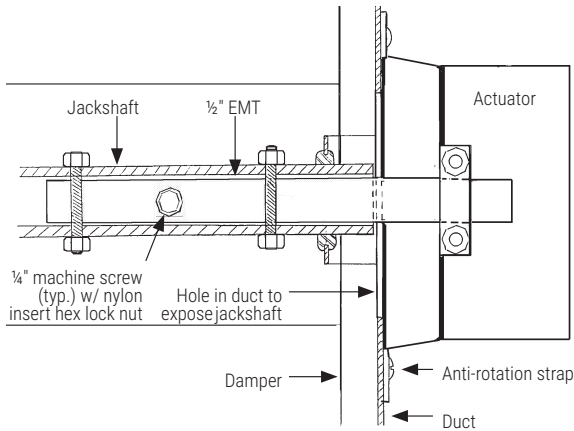

Belimo ZG-JSA- Jackshaft Adaptor

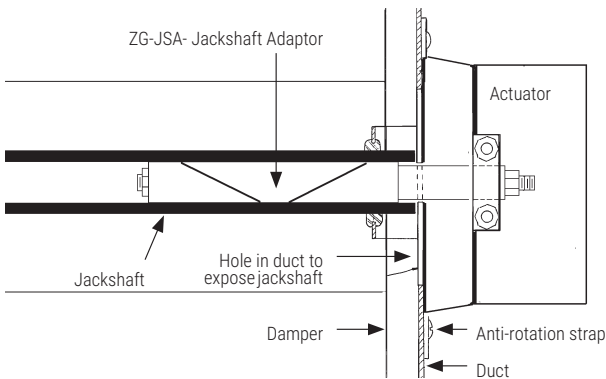
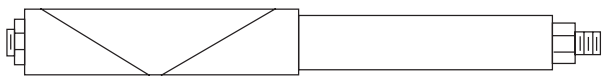

Figure 2.15: Multiple actuators mounted to the same jackshaft

Before mounting the actuator, check for clearance between the damper blades in the fully open position. One actuator per section is the best way to drive this type of damper assembly.

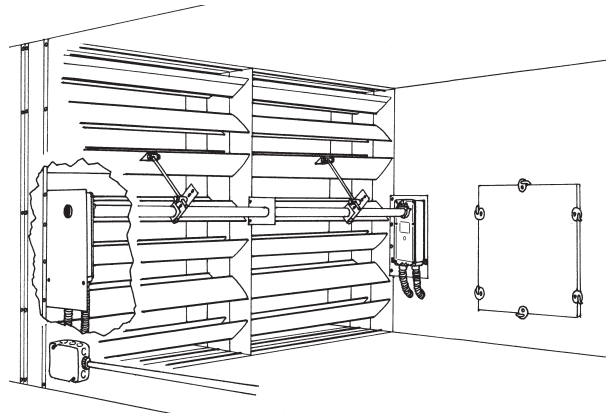

Figure 2.16: Actuator mounted on a round damper

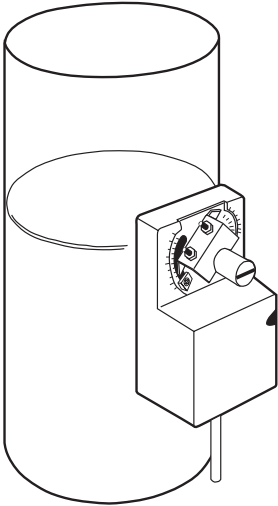

Figure 2.19: Actuator mounted on a VAV dual duct mixing box

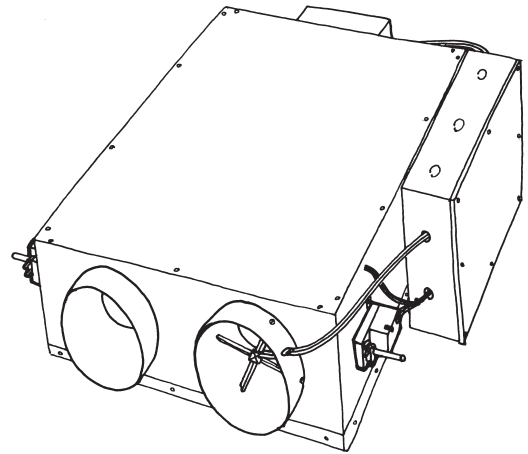

Figure 2.17: Actuator mounted on typical VAV box

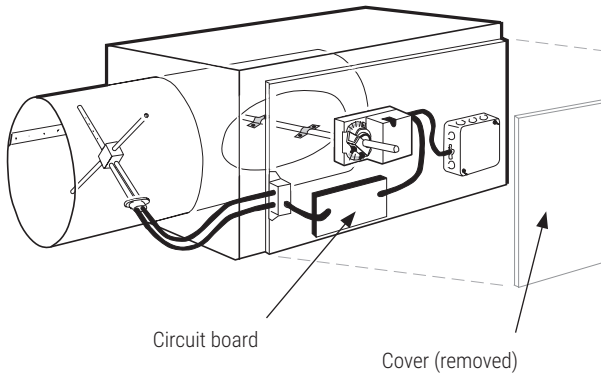

Figure 2.20: Actuator mounted in VAV box replacing rack and pinion type actuator

Rack and pinion type actuator replaced by direct coupled actuator.

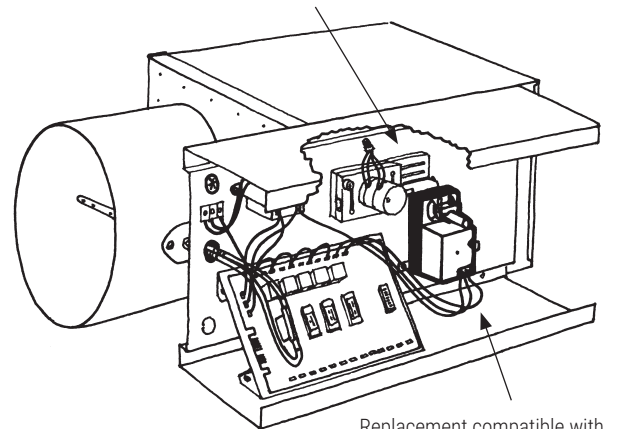
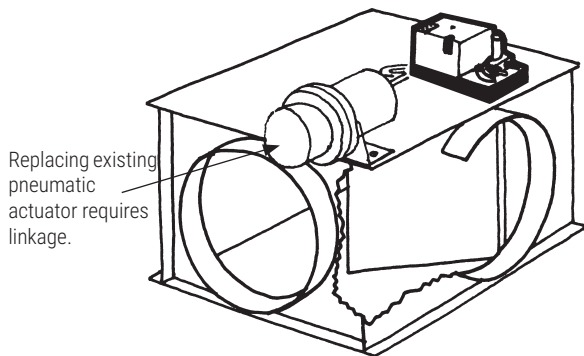

Figure 2.18: Actuator mounted on VAV bypass box is a perfect pneumatic actuator replacement solution



Replacement compatible with existing control system.

Section 3: Non-Direct Coupled Applications

Figure 3.1: Two dampers that share the same shaft operated by one actuator with the crank arm position between the dampers for optimized distribution

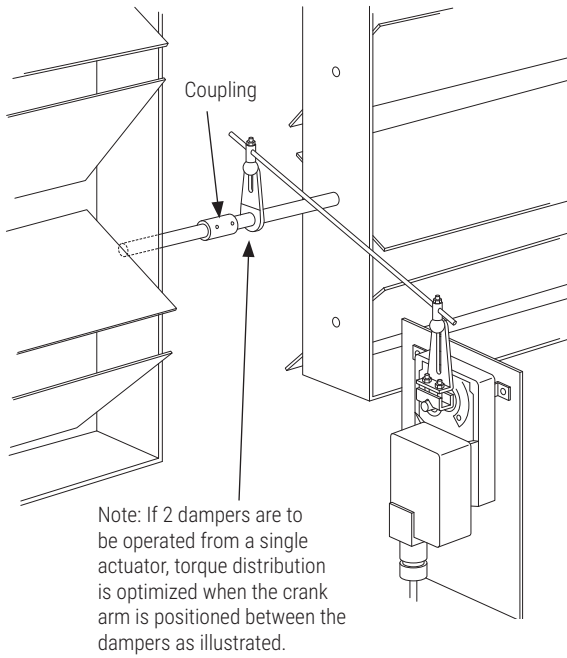

Figure 3.2: Universal mounting bracket is attached to the damper assembly

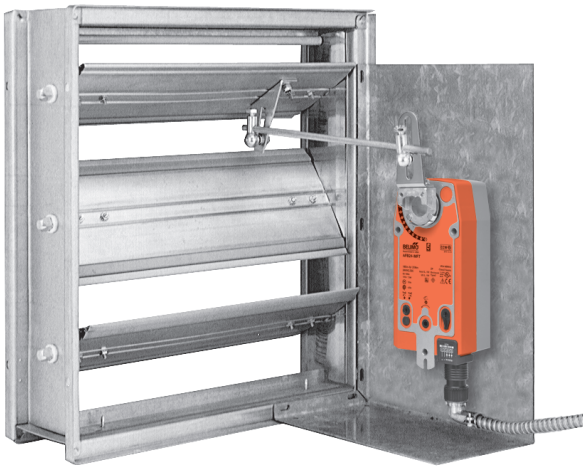

Figure 3.3: Actuator and ZG-118 linkage attached to ductwork with push rod, and damper clip to dampers

The pre punched hole pattern on the ZG-118 linkage allows for a variety of actuator mounting positions (i.e. sideways, upside down, right side up).

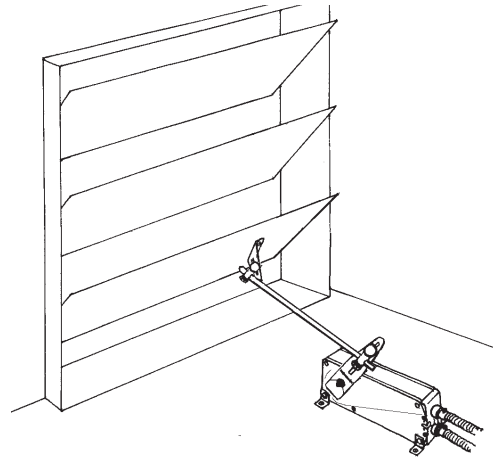

Figure 3.4: Actuator with linkage mounted in the airstream using ZG-AFB crank arm adaptor kit

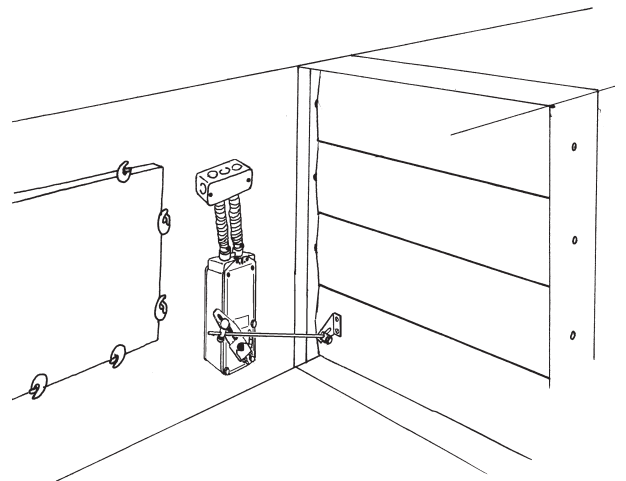

Figure 3.5: Mounting to the side of the damper with use of the ZG-AFB crank arm kit

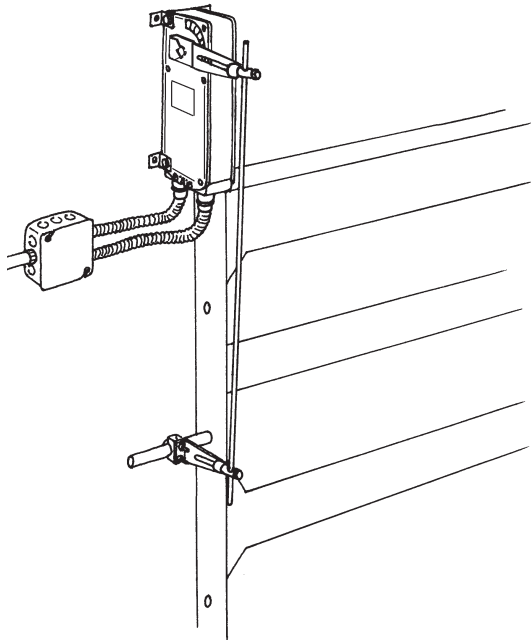

Figure 3.6: For added torque mount two actuators back-to-back on the ZG-104 universal mounting bracket or a field fabricated plate and connect to jackshaft or standard shaft with linkage

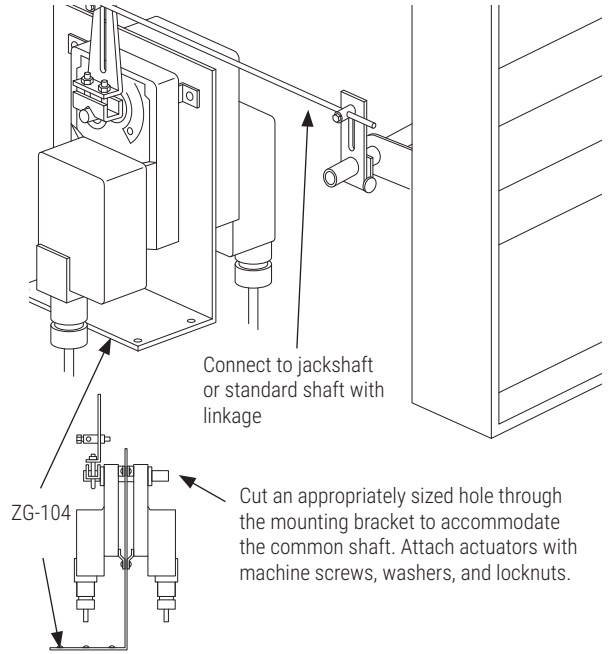

Figure 3.7: Actuator is mounted on the ZG-101 universal mounting bracket or field fabricated plate with crank arm, ball joints, and push rod for connecting the actuator to the damper louvers

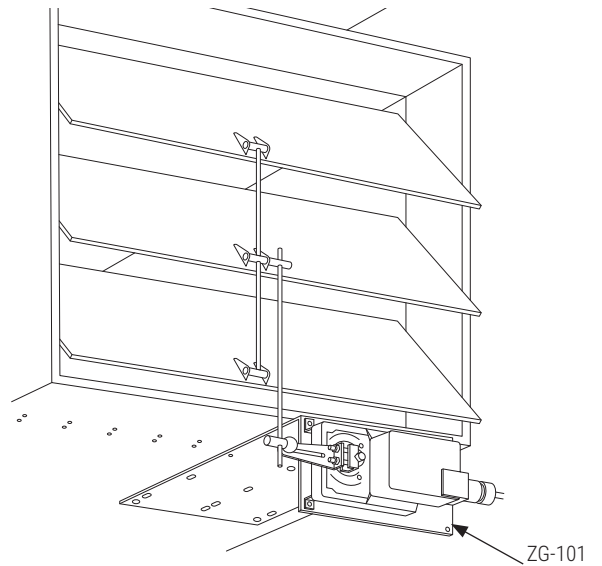

Figure 3.8: ZG-100 universal mounting bracket with crank arm, ball joints, and push rod for connecting the actuator to damper louvers

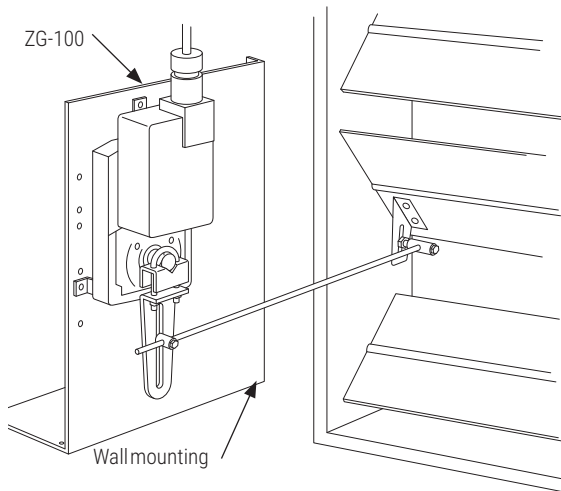

Figure 3.9: ZG-105 universal mounting bracket or a field fabricated plate

Used when little clearance between the damper shaft and the wall along with ZG-NMA crank arm adapter kit for use with AM and NM series actuators.

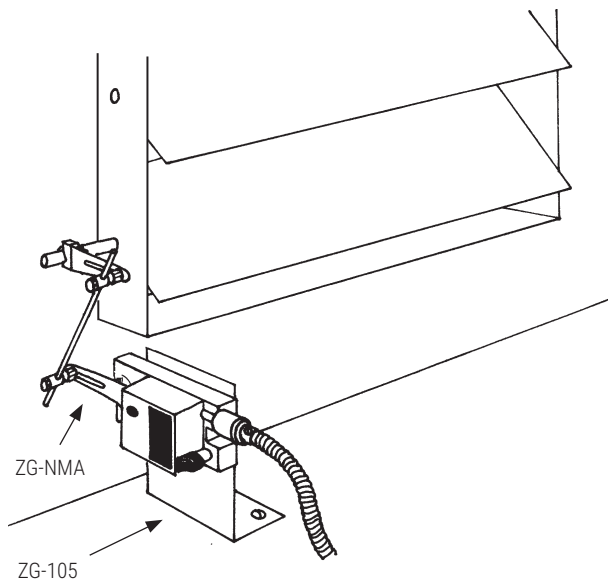

Figure 3.10: ZG-105 universal mounting bracket and ZG-NMA crank arm kit

With little clearance between the damper shaft and the wall. Mount the actuator at a 45° angle with the ZG-105 universal mount bracket using the ZG-NMA crank arm kit will allow for a full 90° rotation. Crank arm final position must be vertical when damper is fully open.

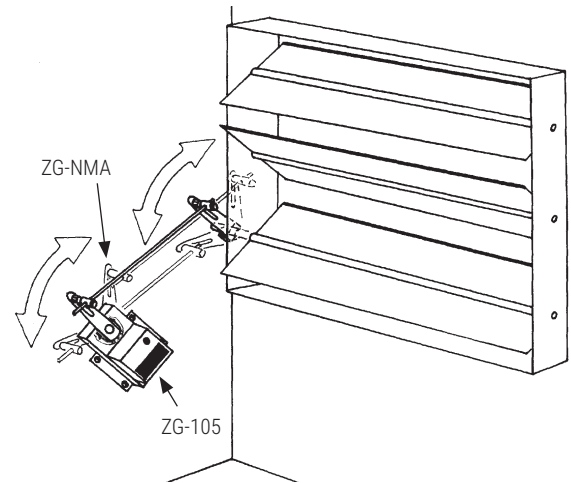
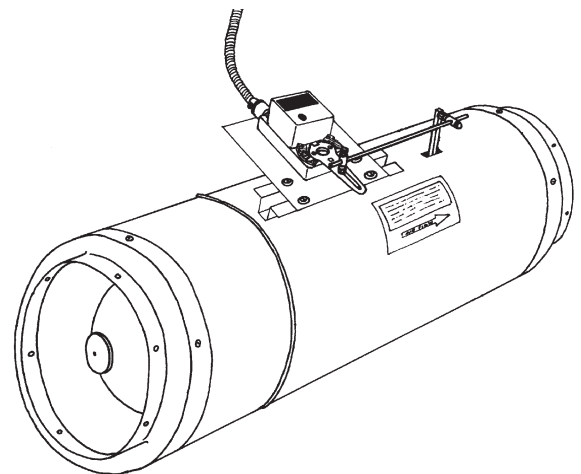

Figure 3.11: Actuator mounted on a field fabricated 16 gauge plate with crank arm kit to control a cone type VAV damper



Jackshafts

Figure 3.12: Actuator is mounted to the damper assembly connected to the jackshaft with a crank arm kit

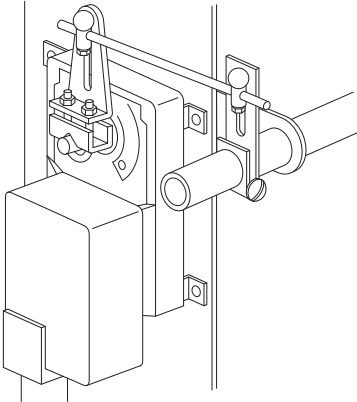

Figure 3.13: Actuator is mounted to the ductwork and connected to the jackshaft with crank arm kit

For large actuators, it is recommended to use an 18-20 gauge field fabricated mounting plate.

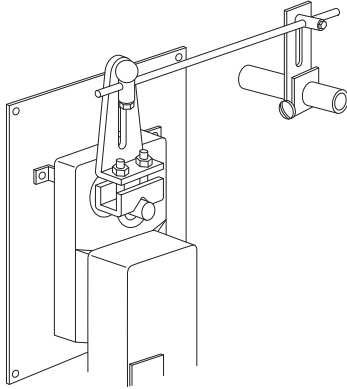

Figure 3.14: Common channel iron is used to allow spacing of the actuator away from the wall

Actuator is mounted adjacent to the wall and is connected to the jackshaft with crank arm kit.

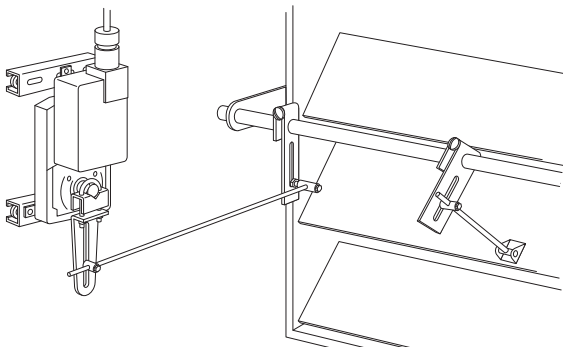

Figure 3.15: ZG-118 universal mounting bracket

Used to mount the actuator to the ductwork connected to the jackshaft with a crank arm kit.

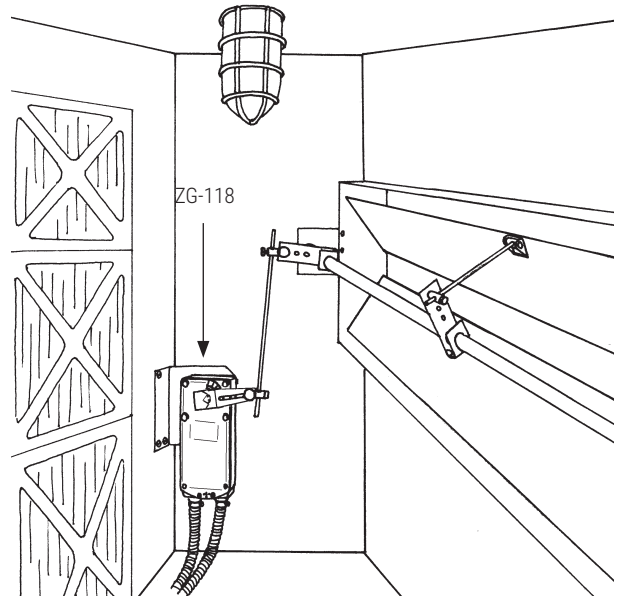
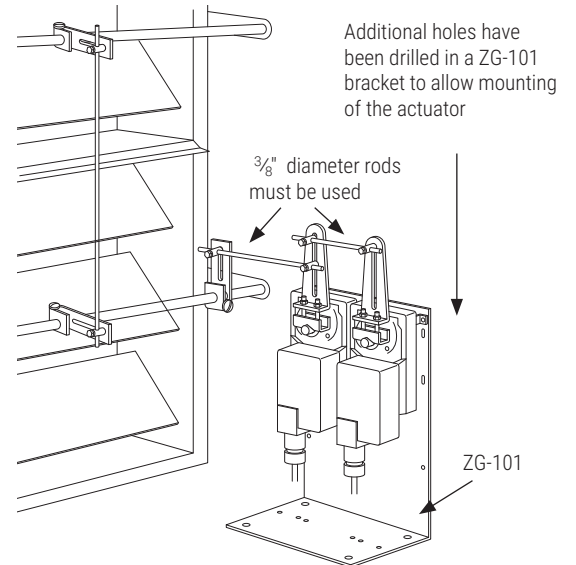

Figure 3.16: ZG-101 universal mounting bracket with additional hole drilled to use with mounting multiple actuators connected with crank arm kit to the jackshaft

This method enables higher torque.



Note: The full 90° travel of the actuators must be used. Otherwise the high force produced may damage the damper.

Inlet Vanes

Figure 3.17: Actuator is mounted to the framework and connected to the inlet vanes with crank arm kit

A second actuator can be mounted on the opposite side of the frame if needed.

Actuator 1 is mounted to vortex frame and direct coupled to linkage shaft

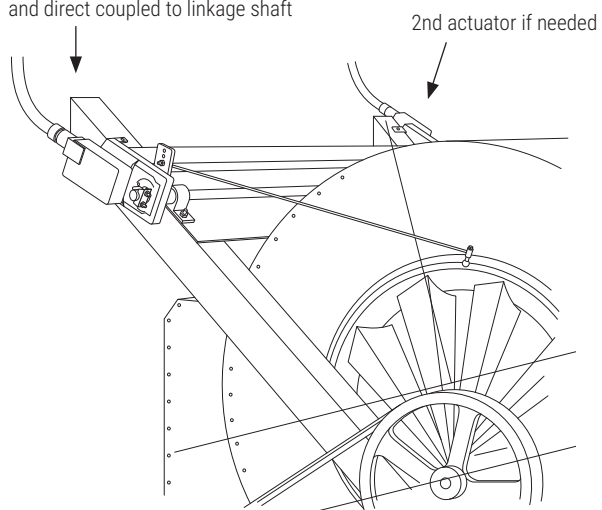

Figure 3.18: Actuator is mounted to the ductwork and connected to the inlet vanes with a crank arm kit

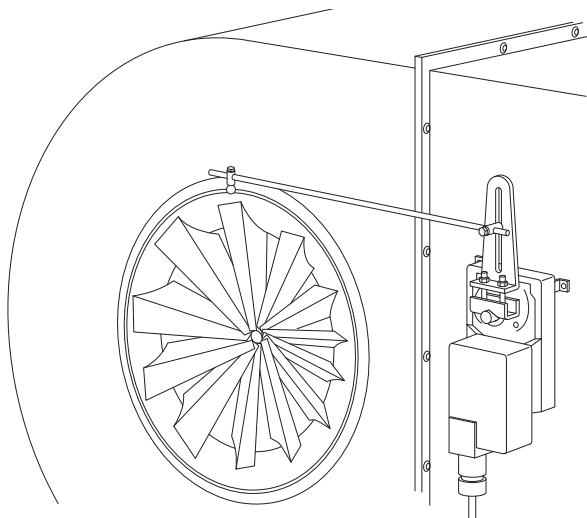

Figure 3.19: Actuator is mounted to the ZG-104 universal mounting bracket or to a field fabricated bracket and connected to the inlet vanes with a crank arm kit

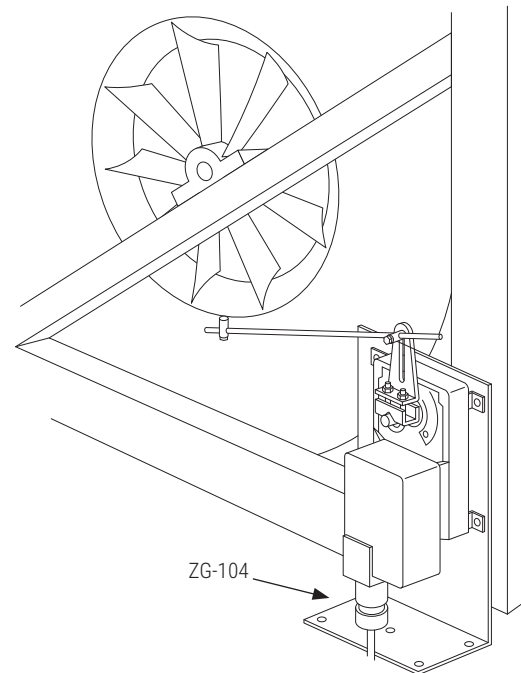
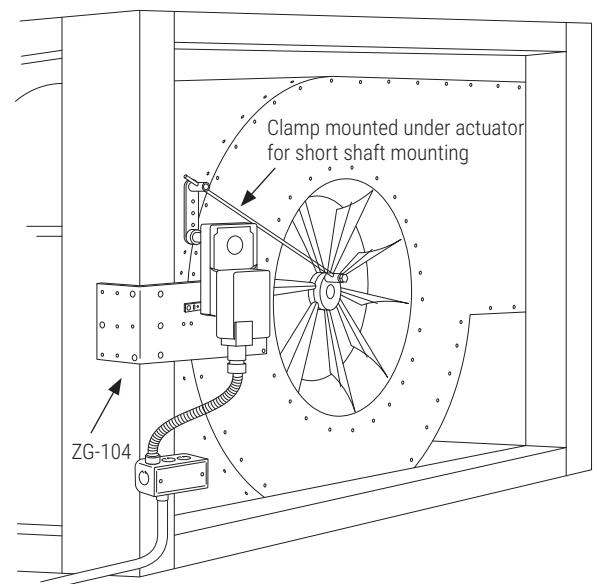

Figure 3.20: Actuator is mounted to the ZG-104 universal mounting bracket or a field fabricated bracket and connected to the inlet vanes with the crank arm kit



Section 4: Conduit Connections

Figure 4.1: Standard electrical configuration

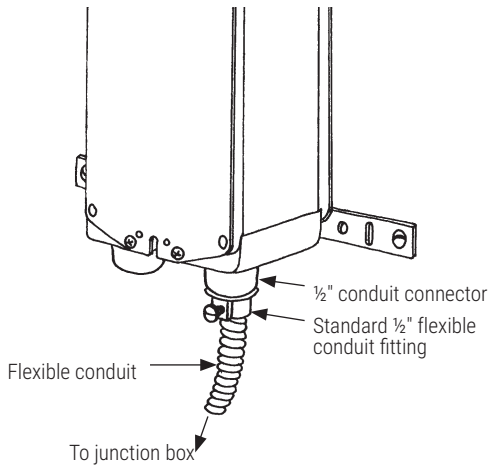

Figure 4.2: Fail-safe actuator with standard electrical configuration

Note: Always use flexible conduit at the actuator.

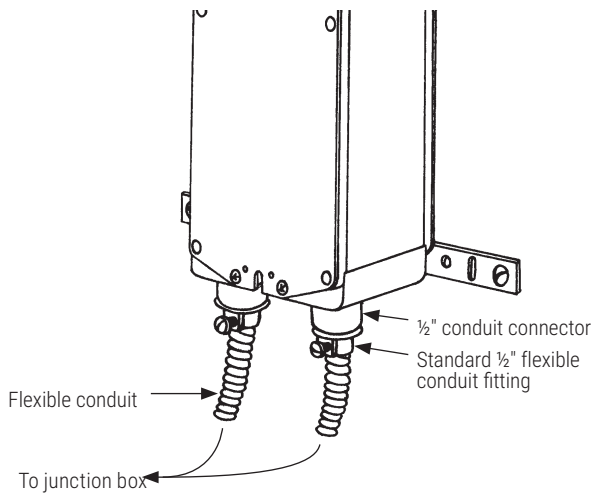

Figure 4.3: Connecting directly to the junction box

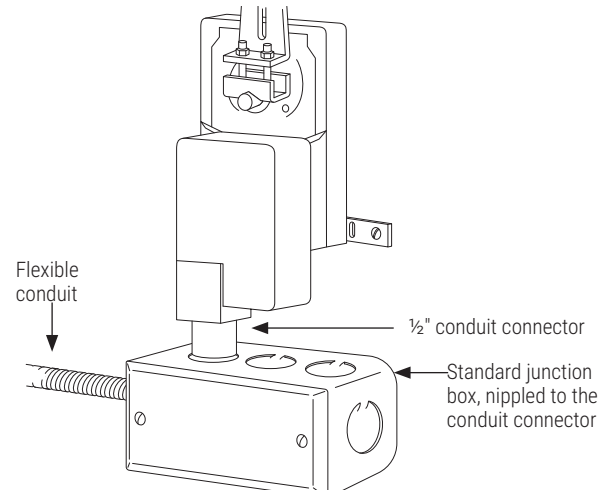
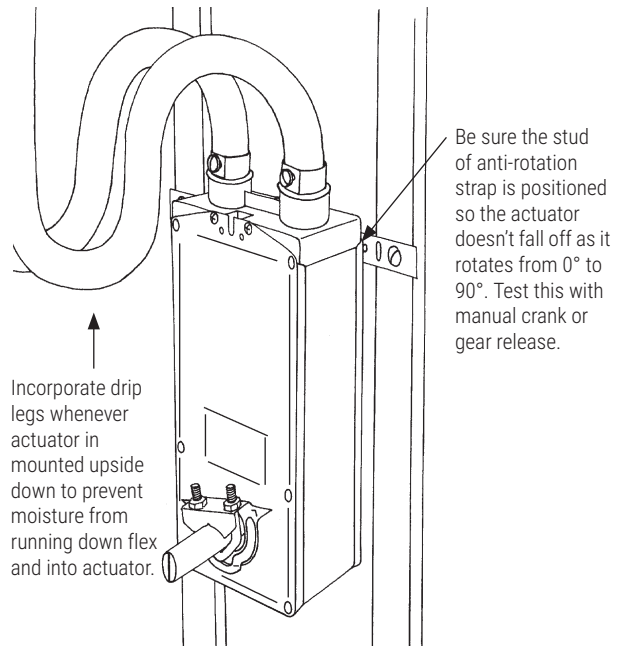

Figure 4.4: Fail-safe actuator connected directly to the junction box



Section 5: Damper Linkages

General Information

Please note: Full available torque may not be realized due to inherent mechanical transfer.

The direct coupled method is the most effective way of mounting an actuator to a damper. However, there are some applications where a linkage must be used along with or in place of the direct coupled.

When using any linkage setup, it is essential that the proper geometry is used. If the geometry is not correct, several problems can occur; such as a risk of binding, incorrect rotation at the damper, the full available torque may not be utilized, or excessive wear to the linkage parts or actuator.

It is possible to arrange the linkage in such a way that special functions can be provided. For example, the torque provided to the damper can be modified so that less torque is provided in the open position of a damper, but more torque would be available for tight close off. The speed of rotation can be changed. The angle of damper rotation can be limited.

General Guidelines

1. The ball joints should be placed as close to the end of the crank arm as possible. This will minimize the forces acting on the linkage parts and reduce any hysteresis in the linkage assembly. Refer to figure 5.1.
2. The distance from the center of rotation of the crank arm to the ball joint should be the same for both crank arms. This provides uniform rotation at both crank arms. Refer to figure 5.1.
3. The push rod and crank arms should be set up so the crank arms on both the actuator and damper rotate 45° from a line perpendicular from the rod to the center of the crank arm rotation. This provides a balanced torque load to the damper and minimizes any chance of the linkage binding. Refer to figure 5.2.
4. Always use the full rotation of the actuator. If the damper rotation is complete and the actuator is still rotating, the linkage may bind up.
5. Always check the operation of the linkage assembly to make sure it operates the damper properly between the fully open and fully closed damper position.

Technical Information

The definition of torque is that it is a turning force. When talking about torque from an engineering standpoint, it is about a force (F), acting on the length of an arm (L) producing a turning force (T) given in a unit which incorporates both a unit of length and force in its description. This equation would be:

$T = L \times F$; where in common applications L would be in inches, F would be in pounds, and T would be shown as inch-pounds or pound-inches

Figure 5.3 shows a crank arm with a length between the pivot point to the ball joint attachment of 4". At the ball joint it shows we are applying a force of 25 pounds. The resulting torque would be 100 in-lbs.

$$T = L \times F = 4 \text{ in} \times 25 \text{ lbs} = 100 \text{ in-lbs}$$

Figure 5.1

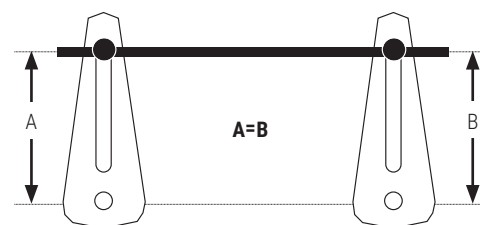

Figure 5.2

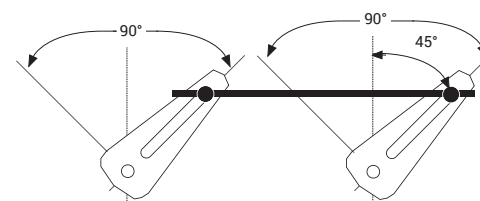
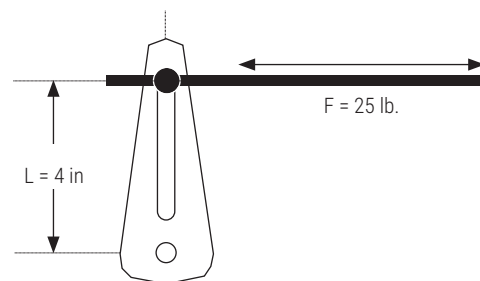

Figure 5.3



When using this equation with actuators it is more common to see it in the following forms:

$$\mathbf{F = T/L \text{ or } L = T/F}$$

The rating of most electronic actuators is given in torque and it is usually required to find either the force from the crank arm or the length of the crank arm for the application. In figure 5.3, if we said the actuator had a torque of 100 in-lbs, and needed a force of 25 lbs, we would need a 4" crank arm.

$$\mathbf{L = T/F = 100 \text{ in-lbs}/25 \text{ lbs} = 4 \text{ in}}$$

Unfortunately, the equation $T = L \times F$ is only correct when the force acts upon the crank arm at a 90° angle. At any angle other than 90° the resultant torque or force is dependent on the crank arm effective radius. The effective radius (R), shown in figure 5.4, is the distance between the point on the push rod which is perpendicular to the center of rotation of the crank arm and the center of rotation.

We now have to substitute the effective radius (R) in place of the crank arm length (L) in the torque equation.

$$\mathbf{T = R \times F \text{ or } F = T/R}$$

Note: R has its greatest value at the point where the crank arm is perpendicular to the push rod. At this point R equals L.

Figure 5.4 shows the same torque and crank arm as figure 5.3; however, the crank arm is now not perpendicular to the push rod. At this point in the crank arm rotation we show an R of 2". With the output torque of 100 in-lbs, the resulting force at this point is 50 lbs.

$$\mathbf{F = T/R = 100 \text{ in-lbs}/2 \text{ in} = 50 \text{ lbs}}$$

As the effective radius (R) changes during the crank arm rotation, the relationship between torque, force, and even rotational speed changes. By analyzing the crank arm orientation between the actuator and damper, special set ups can be made to optimize certain damper applications.

Figure 5.4

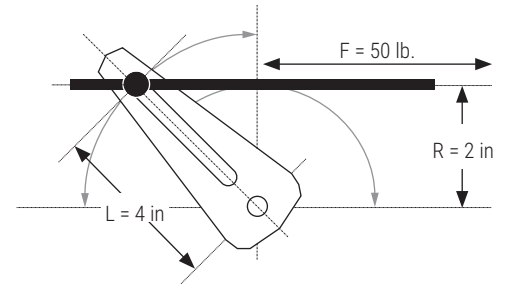

Special Applications

High Close-Off Torque

Low leakage dampers with blade seals require a greater close-off torque than the normal operating torque. By setting up the linkage correctly, the torque provided to the damper at close-off can be multiplied.

Figure 5.5 shows a linkage arrangement where, when the damper is in the closed position, the angle between the actuator crank arm and push rod is relatively large. This angle makes the resulting effective radius at the actuator (R_a) small; this in turn causes a higher force to act on the push rod. When the damper is at close-off, the damper crank arm is adjusted so it is at an angle creating a relatively large effective radius (R_d) at the damper. The large force from the push rod is multiplied by the effective radius (R_d) at the damper and the result is a higher torque at the close off position. The torque from the actuator is actually multiplied at this point by a factor M which is equal to R_d/R_a .

$$M = R_d/R_a$$

One important thing to remember is that at the opposite end of rotation the torque can be reduced to a point where minor binding or friction could lock up the damper.

Faster Response Time at Damper

Figure 5.6 shows an application where the actuator crank arm is approximately twice as long as the damper crank arm. This results in a rotation at the damper shaft of 90° with only 45° of rotation at the actuator. Using only 45° of the actuator's rotation gives the advantage of the damper operating at twice the actuator's normal speed. A drawback is that the actuator torque is cut in half. It is recommended that the actuator be limited to only 45° of rotation either mechanically (preferred) or electrically. If this is not done, it is possible that the linkage or the damper may be damaged as the actuator continues to rotate.

Figure 5.7 shows an application where we are limiting the degree of rotation while still using the full 90° rotation of the actuator. The crank arm shown of the actuator is shorter than the arm on the damper. Because of the smaller arc produced at the actuator arm, the push rod travel cannot rotate the damper arm through a full 90° rotation.

General Comments

The use of a linkage assembly can be advantageous if a solution to a special need is required. However, great care must be taken in planning the linkage geometry. Any change made to the linkage has an effect on more than one condition. As an example, if you adjust the linkage for more torque, you will at the same time effect the damper rotational speed and the angle of the damper rotation. In any special application it is necessary to use a trial-and-error, back-and-forth method to set the required parameters. This can be a very time consuming process, but it should be done.

Figure 5.5



Figure 5.6

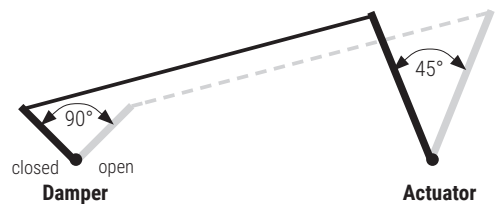

Figure 5.7

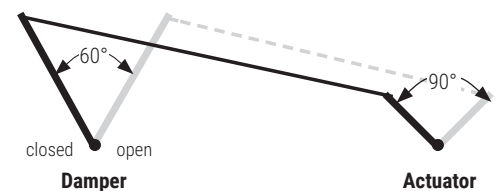

Figure 5.8: Back-to-back method of increasing breakaway torque

Point 1 is the start point, and 3 is the end point. Damper movement is slow from positions 1 to 2 and increases speed to position 3. For example, if a 90 in-lbs actuator is used the torque at 1 is approximately 180 in-lbs and at location 3 is 45 in-lbs. The highest torque is supplied where it is most needed, which is at the beginning of the movement of the damper to assure breakaway from the side seals.

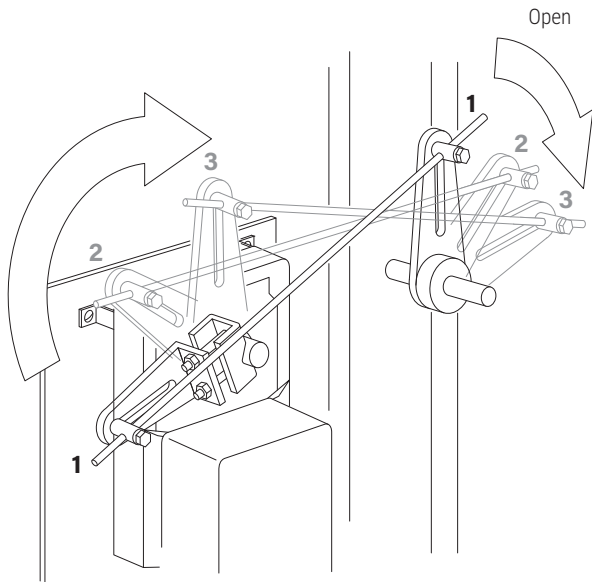

Figure 5.9: Typical parallel crank arm operation

Most common methods where both crank arms remain parallel throughout the whole movement, ensuring consistent torque at all times.

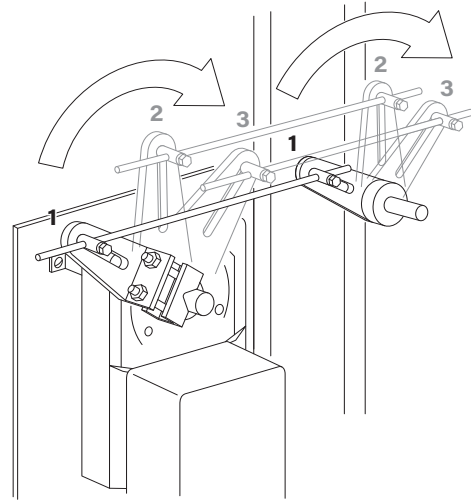
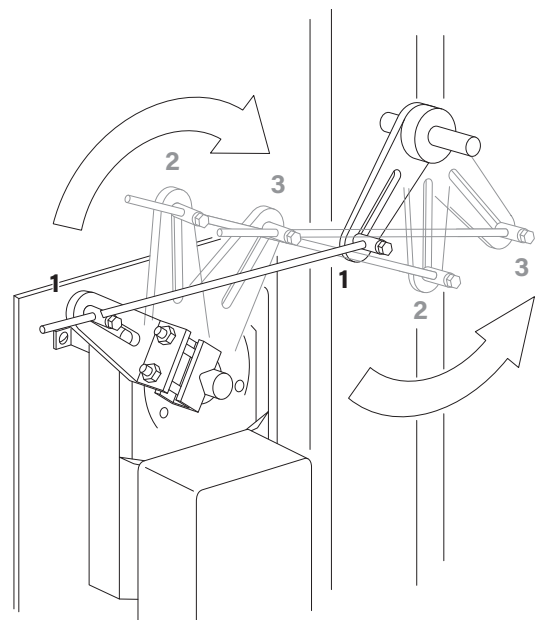

Figure 5.10: Over-and-under method

The crank arms are set in opposite directions. This is used in areas where space is limited.



Exceptional service

For over 40 years, Belimo successfully focuses on the heating, ventilation, and air conditioning markets providing quality solutions that will increase energy efficiency and reduce installation cost with the fastest delivery times in the industry. Our innovative products have always been designed to help achieve objectives better, faster, and more economically. Investing in new technology is key to our success, and Belimo will continue to offer products to help businesses succeed.



5-year warranty



Global support



Tested quality



On-time delivery



Extensive service



Complete product range

Belimo Americas

USA, Latin America, and the Caribbean: www.belimo.us
Canada: www.belimo.ca, Brazil: www.belimo.com.br

